

AIR CONDITIONING SYSTEM

6810-00/6810-02/6810-03/6810-05/6810-06/6810-10/6810-11/
6810-12/6810-13/6810-20/6810-23/6810-24/6820-00/6820-01/
6820-02/6830-00/8520-14/8520-15/8520-18/

INDEX

AIR CONDITIONING SYSTEM

GENERAL INFORMATION

1. SPECIFICATIONS.....	3
2. MAJOR CHANGES.....	5

OVERVIEW AND OPERATING PROCESS

1. OVERVIEW.....	6
2. LAYOUT.....	8
3. FATC SYSTEM OPERATION PROCESS.....	13
4. MTC SYSTEM OPERATION PROCESS.....	28
5. PTC HEATER OPERATION PROCESS..	35
6. CIRCUIT DIAGRAM.....	38

CONFIGURATION AND FUNCTIONS

6810-00 AIR CONDITIONER MODULE COMPONENTS.....	40
6820-00 AIR CONDITIONER HOSE & PIPE.....	41
6830-00 AIR DISTRIBUTOR.....	42
6810-20 HEATER AND A/C CONTROL.....	43
6810-10 AIR CONDITIONER MODULE.....	49
6810-12 MODE ACTUATOR.....	51
6810-02 INTAKE ACTUATOR.....	54
6810-11 TEMP ACTUATOR.....	57
6810-23 INCAR SENSOR.....	60
6810-00 WATER TEMPERATURE SENSOR.....	62
6810-24 INTAKE SENSOR.....	64
6810-06 MOS MODULE.....	66
6810-05 BLOWER MOTOR.....	68
6810-03 A/C FILTER.....	70
8520-18 SUN LOAD SENSOR.....	71
8520-14 AMBIENT TEMPERATURE SENSOR.....	74
8520-15 PTC HEATER.....	76
6820-02 A/C COMPRESSOR.....	80
6820-01 A/C CONDENSER.....	81

INDEX

AIR CONDITIONING SYSTEM

REMOVAL AND INSTALLATION

6810-20 HEATER AND A/C CONTROL PANEL.....	82
6810-00 AIR CONDITIONER MODULE.....	92
6810-13 HEATER CORE.....	103
6810-12 MODE ACTUATOR.....	105
6810-02 INTAKE ACTUATOR.....	107
6810-11 TEMP ACTUATOR.....	109
6810-23 INCAR SENSOR.....	111
6810-00 WATER TEMPERATURE SENSOR.....	112
6810-24 INTAKE SENSOR.....	115
6810-06 MOS MODULE.....	119
6810-05 BLOWER MOTOR.....	121
6810-03 A/C FILTER.....	123
8520-18 SUN LOAD SENSOR.....	125
8520-14 AMBIENT TEMPERATURE SENSOR.....	126
8520-15 PTC HEATER.....	128
6820-02 A/C COMPRESSOR.....	130
6820-01 A/C CONDENSER.....	132



AIR CONDITIONER SYSTEM**6810-00****GENERAL INFORMATION****1. SPECIFICATIONS**

Unit	Item	Specification	
Heater	Core size (mm ³)	200 x 168.5 x 23.5	
	Capacity (kcal/h)	4,800	
Evaporator	Core size (mm ³)	254.8 x 196.7 x 60	
	Capacity (kcal/h)	4,700	
Blower motor	Supply power (W)	240 + 10% Max (at 12 V)	
	Fan speed (rpm)	2900±200 Max (Rec. Mode: 420m ³ /h)	
PTC	Supply power	1 kW	
Condenser	Core size (mm ³)	588 x 455 x 16 (2,625)	
	Capacity (kcal/h)	12,000	
	Capacity of receiver drier	250 cc	
Compressor	Volume	170 cc/rev	
	Diameter of pulley	Ø120	
	Max. continuous speed	8,000 rpm	
	Voltage	DC 12 V	
	Current consumption	2.2 A	
	Rated voltage	DC 13.5 V	
Heater & A/C control assembly (FATC)	Operating voltage	DC 9 V to 16 V	
	Operating temperature	-30 ~ 80 °C	
	Max. current consumption	2.5 A	
	Dark current	1.1 mA	
	Button switch	Type	Push type (self-return)
		Operating force	2.54±0.5N
	Temperature & air distribution switch	Type	Dial type
		Rotation angle	360°

Modification basis	
Application basis	
Affected VIN	

Item	Component		Specification
Heater & A/C control assembly (MTC)	Rated voltage		DC 13.5 V
	Operating voltage		DC 9 V to 16 V
	Operating temperature		-30 ~ 80°C
	Max. current consumption		2.5 A
	Dark current		1.1 mA
	Button switch	Type	Push type (self-return)
		Operating force	2.54±0.5N
	Temperature switch	Type	Dial type
		Rotation angle	220°
	Fan speed switch	Type	Dial type
Rotation angle		180°	
Refrigerant	Type	R134a	
	Volume	430 ± 30 g	

شرکت دیجیتال خودرو (مسئولیت محدود)



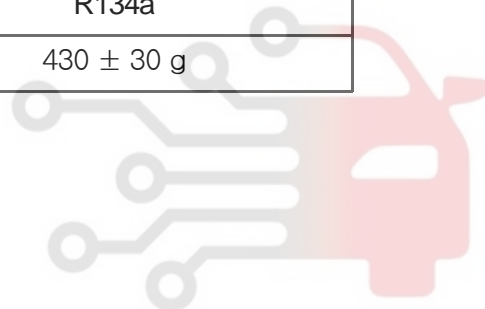

اولین سامانه دیجیتال تعمیرکاران خودرو در ایران



Modification basis	
Application basis	
Affected VIN	

2. MAJOR CHANGES

► Changes in heater and control assembly

Heater & A/C control assembly	
Old	New
With FATC	With FATC
	
With MTC	With MTC
	
<p>Heater and A/C control assembly design and switch arrangement changed</p> <ul style="list-style-type: none"> - Digital display (LCD display) with FATC used - Push button type switch used (self-return type) 	

► Change of air conditioner pipe

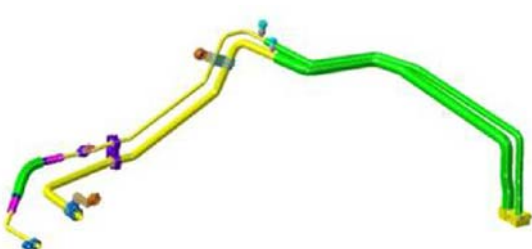
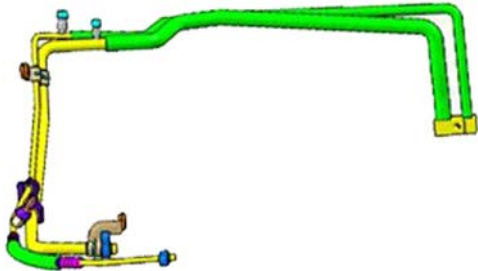
Liquid and suction pipe	
	
<p>Liquid and suction pipe route changed due to change of headlamp mounting bracket</p>	

Modification basis	
Application basis	
Affected VIN	

OVERVIEW AND OPERATING PROCESS

1. OVERVIEW

The climate system in the vehicle is an air regulating system which keeps the indoor air pleasant through the heating, ventilation and air conditioning systems. The air conditioning systems fall in to two categories; FATC (Full Automatic Temperature Control), which is a temperature control device which receives signals from various sensors (ambient temperature sensor, water temperature sensor, sun-load sensor, AMP sensor) and control switches to control the blower motor and all kinds of actuator (mode door actuator, mix door actuator, air source door actuator) through MICOM in the FATC, therefore, the interior temperature of the vehicle is kept to the temperature which is set by a driver and MTC (Manual Temperature Control), which controls all the actuator and blower motor by the driver.

دیجیتال خودرو

شرکت دیجیتال خودرو سامانه (مسئولیت محدود)

اولین سامانه دیجیتال تعمیرکاران خودرو در ایران



Modification basis	
Application basis	
Affected VIN	

Memo

دیجیتال خودرو

شرکت دیجیتال خودرو سامانه (مسئولیت محدود)

اولین سامانه دیجیتال تعمیرکاران خودرو در ایران



2. LAYOUT

1) Exterior Layout

Liquid and suction pipe

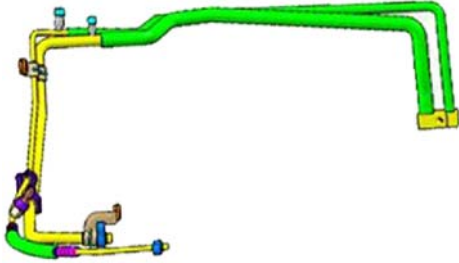

The high/low-pressure A/C refrigerant flows through this pipe. It is fitted with the refrigerant pressure sensor.

Refrigerant pressure sensor



It is mounted to the latter part of the right headlamp. It converts the A/C refrigerant pressure to voltage value and sends it to the engine ECU.

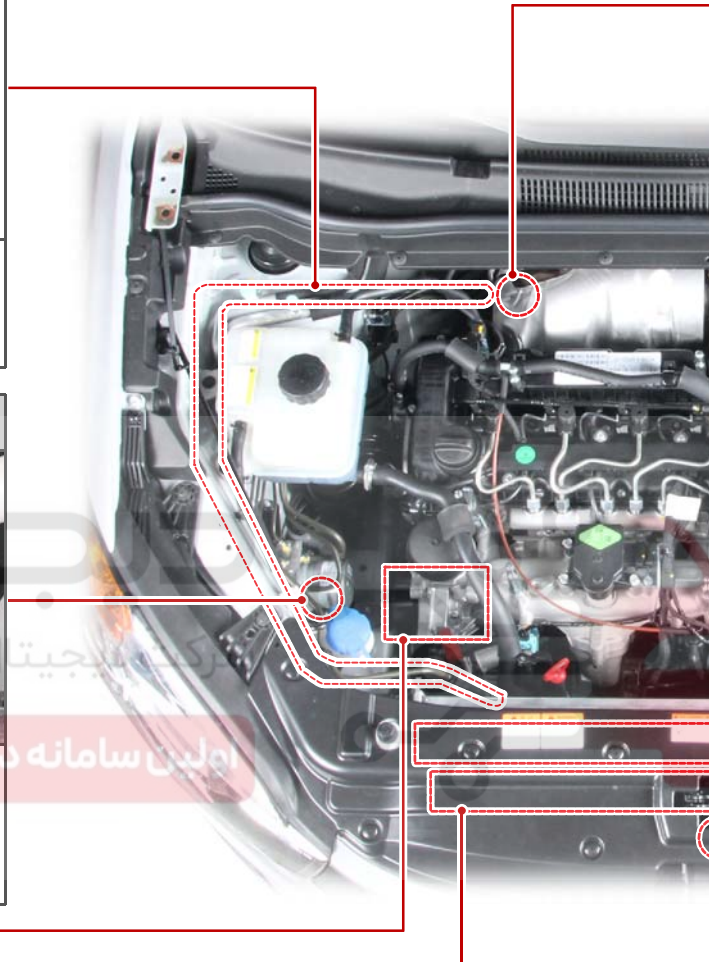

A/C compressor



It is installed to the left side of the engine assembly, compresses the low-temperature and low-pressure coolant and converts it to the high-temperature and high-pressure coolant. Then, it sends the coolant to the A/C condenser.

Electric fan



It cools down the A/C condenser to speed up the compression for the refrigerant in the condenser.

Modification basis	
Application basis	
Affected VIN	

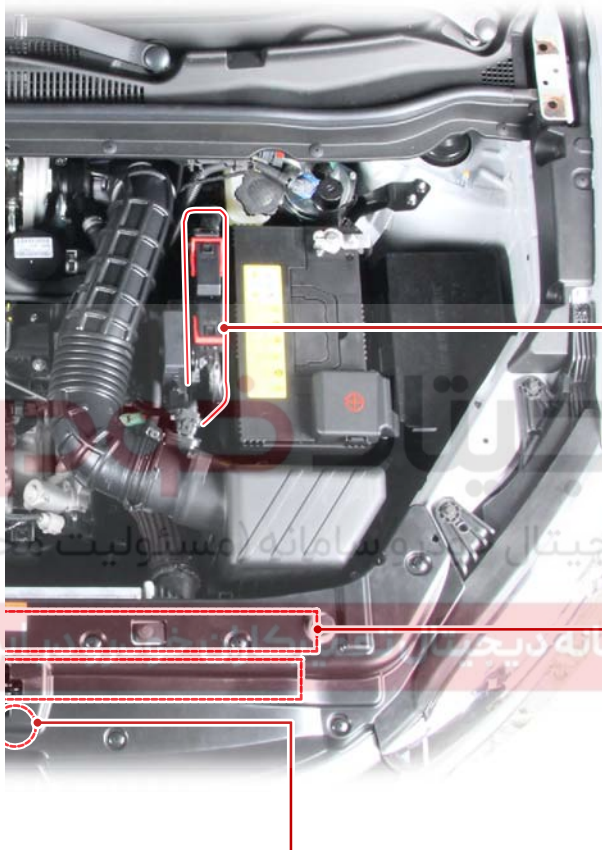

Expansion valve



It is mounted to the inlet of the evaporator core and supplies the appropriate quantity of refrigerant to the evaporator.

Engine ECU



It controls the A/C compressor, electric fan and PTC heater according to the signal from the A/C control panel.

Ambient temperature sensor



It is mounted to the front section of the vehicle and detects the ambient temperature to send the voltage value according to the resistance change to the heater and A/C control assembly.

A/C condenser & receiver drier





Integrated receiver drier



It is installed in front of vehicle and condenses vapor refrigerant into low temperature and high pressure liquid refrigerant. The receiver drier is built in it.

Modification basis	
Application basis	
Affected VIN	

2) Interior Layout

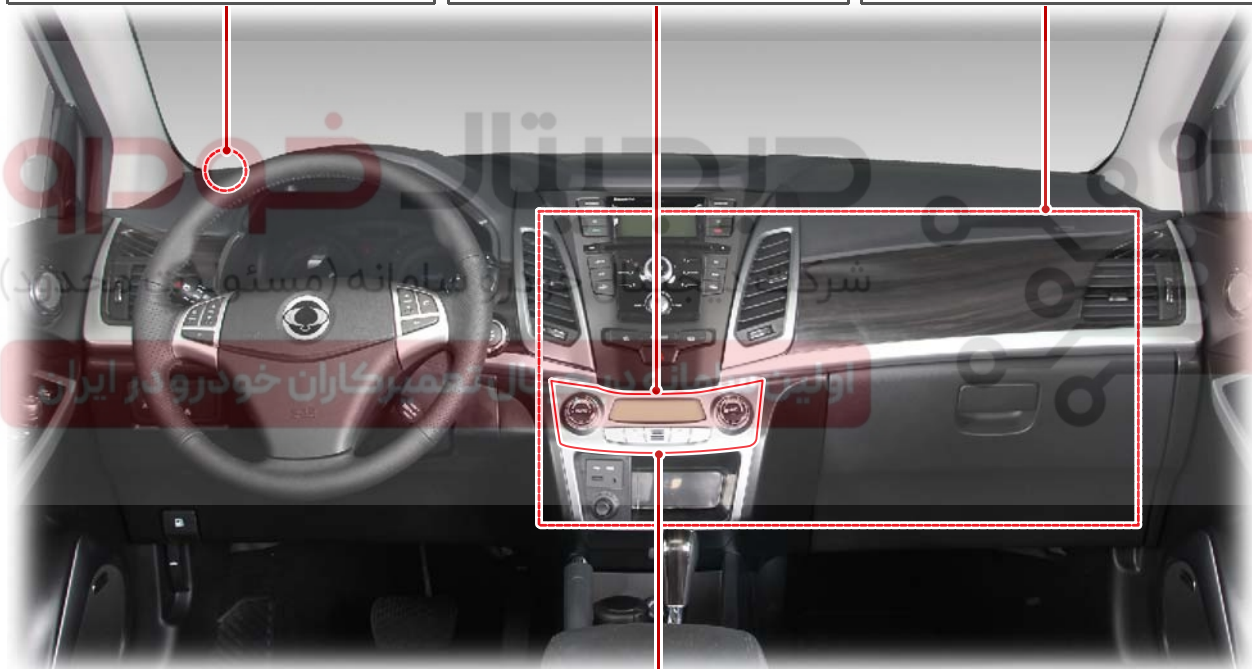

Sun load sensor	Incar sensor	Air conditioner module
		
<p>It is mounted to the upper left-hand of the instrument panel and detects the sun-load enters to the interior through the windshield with a photo diode.</p>	<p>It is mounted to the rear of the heater and A/C control panel (with FATC) and detects the interior air temperature drawn through the sensor inlet.</p>	<p>It is mounted to inside of the instrument panel and has the evaporator core, heater core, PTC heater and corresponding actuator and different sensors.</p>







Heater & A/C control assembly	
With FATC	With MTC
	
<p>It falls in to two categories; FATC (Full Automatic Temperature Control) and MTC (Manual Temperature Control), which controls the air conditioning system's operation.</p>	

Modification basis	
Application basis	
Affected VIN	

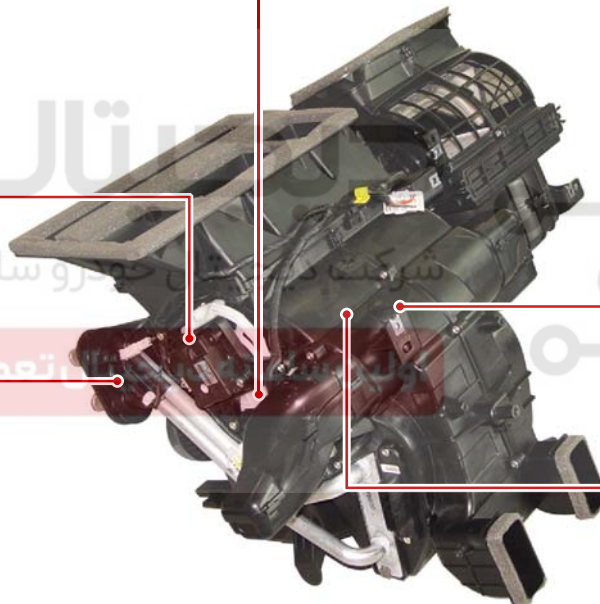
3) Air Conditioner Module Layout

<p>Mode actuator</p>	<p>Temp actuator</p>	<p>Evaporator core</p>
		
<p>It controls the air outlet damper to the five directions according to the control command from the heater and A/C control assembly.</p>	<p>It changes the air mix door opening according to the control command from the heater and A/C control assembly.</p>	<p>It cools the surrounding air by passing through the low-temperature and low-pressure refrigerant sprayed from the expansion valve.</p>



<p>Water temperature sensor</p>	<p>Heater core</p>	<p>Intake sensor</p>
		
<p>It is mounted to the heater pipe part and detects the coolant temperature.</p>	<p>It is mounted to the left-hand of the air conditioner module and heats the indoor using the heat of the engine coolant.</p>	<p>It is mounted to the side of evaporator core and detects the temperature of the evaporator core.</p>

Modification basis	
Application basis	
Affected VIN	

Intake actuator



It changes the air source selection mode according to the control command from the heater and A/C control assembly.

A/C filter

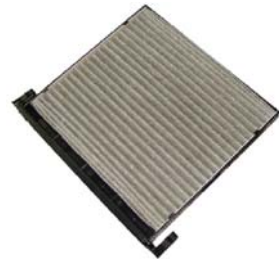

It is mounted to the top of the blower motor and filters the air before it is discharged through the duct.

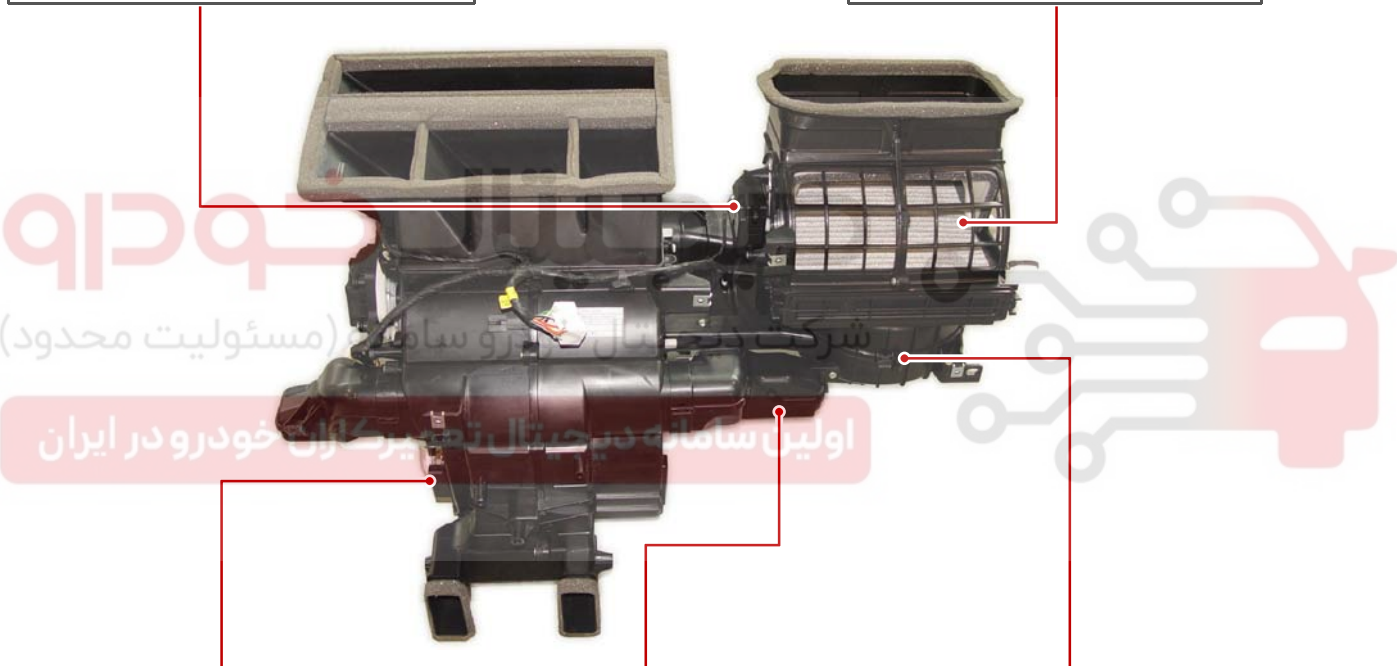

PTC heater



It is mounted to the heater air outlet in the heater module and warms the air from the heater to the air vent.

MOS module



It controls the rotation speed of the blower motor by receiving the fan speed control signal from the heater and A/C control assembly.

Blower motor



It is mounted to the bottom of the blower box and sends the air inside of the vehicle.

Modification basis	
Application basis	
Affected VIN	

3. FATC SYSTEM OPERATION PROCESS

1) Input/Output Factors

FATC (Full Automatic Temperature Control) is a temperature control device which receives signals from various sensors (interior temperature sensor, ambient temperature sensor, water temperature sensor, sun-load sensor) and control switches to control the blower motor and all kinds of actuator (mode door actuator, mix door actuator, air source door actuator) through MICOM in the FATC, therefore, the interior temperature of the vehicle is kept to the temperature which is set by a driver. The driver can check the status of A/C through the LCD display of the A/C control assembly. The fan speed and the temperature are adjusted automatically by the input values from different sensors to keep indoor air fresh. If the FATC system has any defect, the self-diagnosis is used for the system to make it easier to detect the fault.

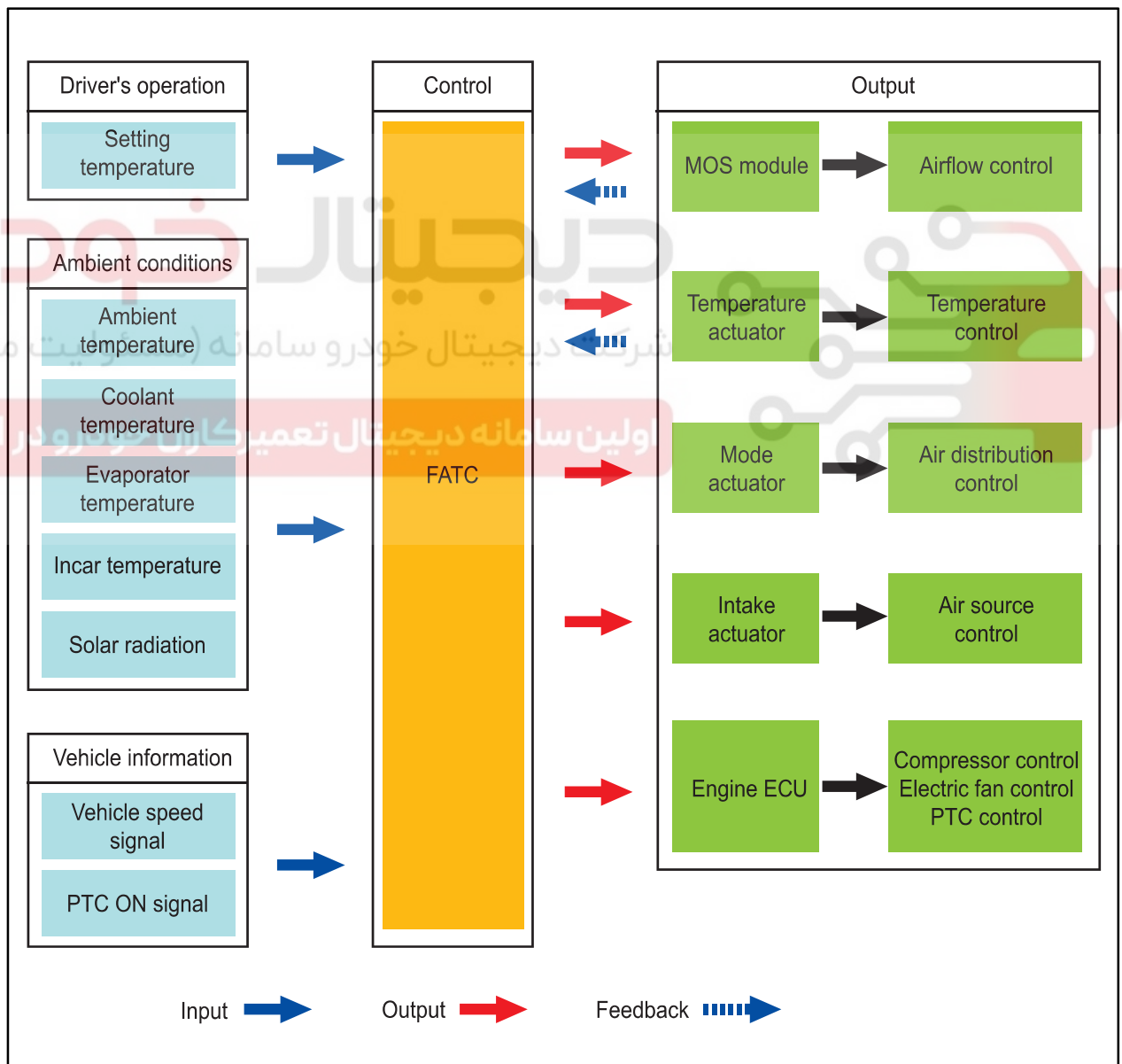

Modification basis	
Application basis	
Affected VIN	

2) Function

(1) Function of heater and A/C control assembly with FATC

LCD display

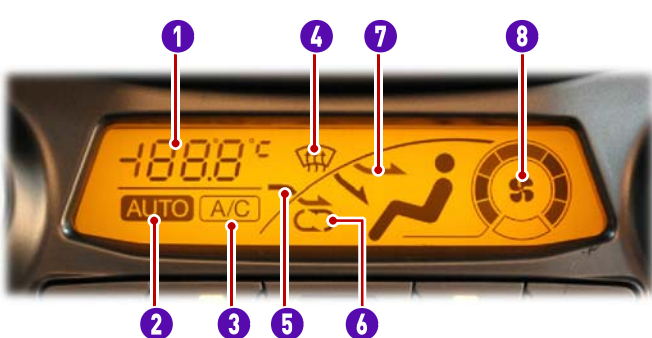

1. Indoor set temperature indicator
2. AUTO mode operation indicator
3. A/C operation indicator
4. Defrost mode indicator
5. Fresh air mode indicator
6. Air recirculation mode indicator
7. Vent & foot mode indicator
8. Fan speed indicator

Temperature control dial

To set the temperature, turn the dial to the left or right. The LCD display shows the set temperature.

AUTO switch

When pressing this switch, "AUTO" is shown on the display and the fan speed and air distribution mode are adjusted automatically to keep interior temperature to the set temperature.

ON/OFF switch

Pressing the switch turns the FATC on/off. When the FATC is turned on, it memorizes the previous status before becoming off.

Defroster mode switch

This is used to remove the condensation from the windshield. When you press the switch, the indicator comes on and the air distribution is changed to the windshield at the same time, then the air conditioner starts to operate. When you press the switch again, the indicator goes off and the air distribution returns to the previous status.



Modification basis	
Application basis	
Affected VIN	

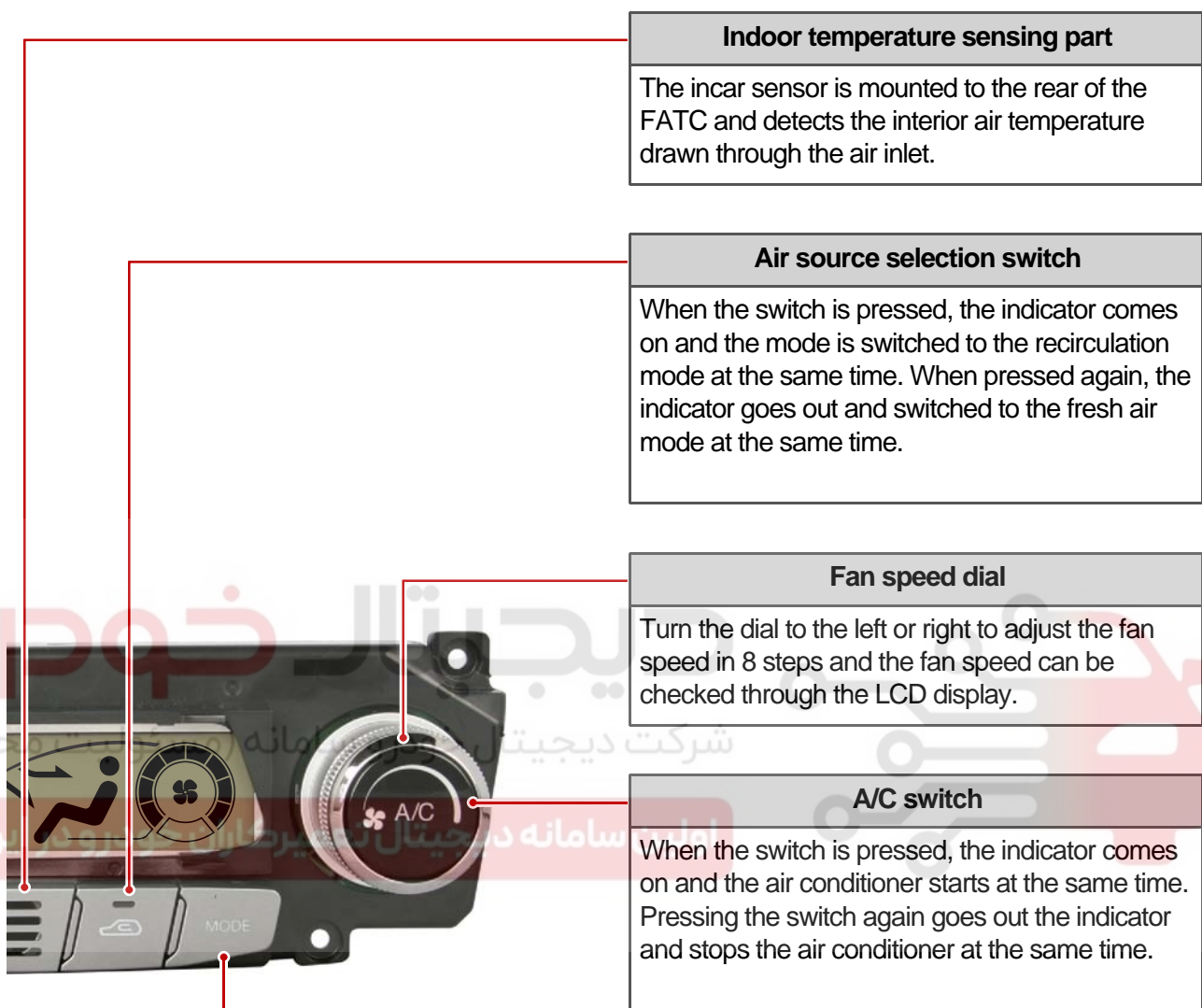

Indoor temperature sensing part
The incar sensor is mounted to the rear of the FATC and detects the interior air temperature drawn through the air inlet.

Air source selection switch
When the switch is pressed, the indicator comes on and the mode is switched to the recirculation mode at the same time. When pressed again, the indicator goes out and switched to the fresh air mode at the same time.

Fan speed dial
Turn the dial to the left or right to adjust the fan speed in 8 steps and the fan speed can be checked through the LCD display.

A/C switch
When the switch is pressed, the indicator comes on and the air conditioner starts at the same time. Pressing the switch again goes out the indicator and stops the air conditioner at the same time.

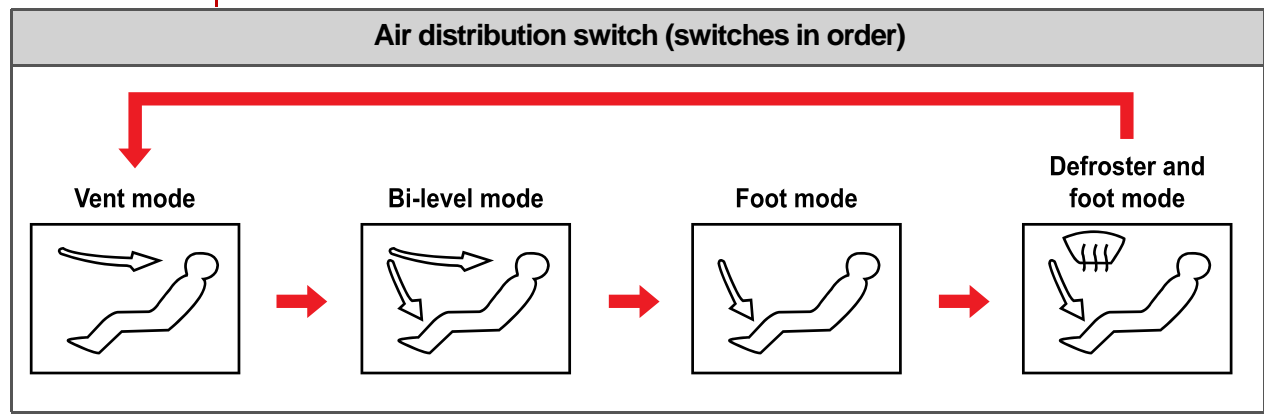

Modification basis	
Application basis	
Affected VIN	

(2) Temperature control

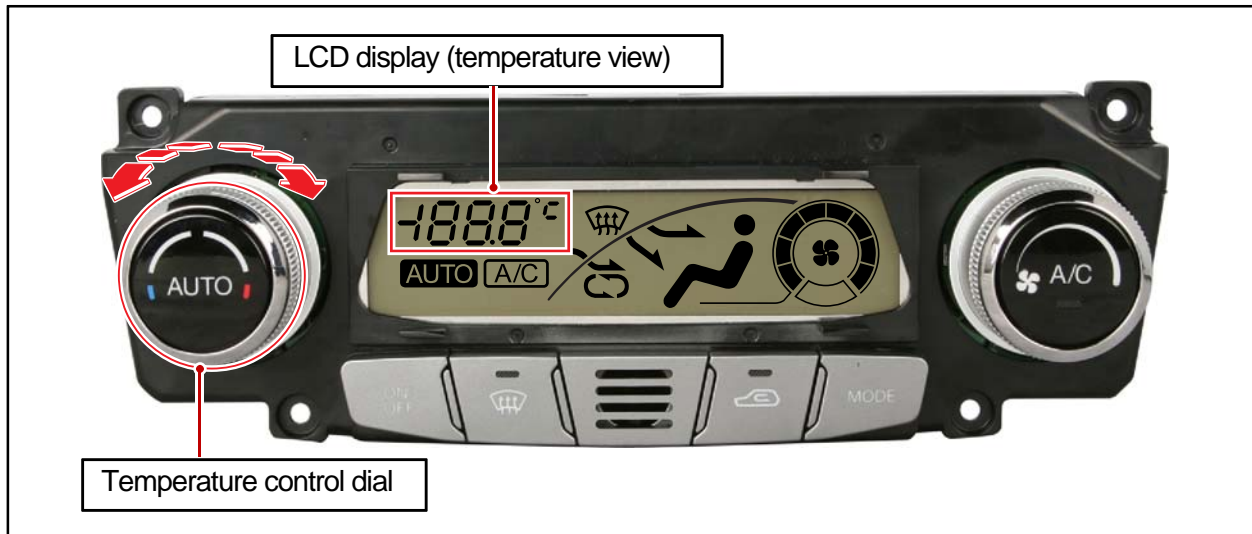

The blowing air temperature is controlled by the temp actuator and the set temperature can be checked via the LCD display.

► Manual control

The discharge air temperature is controlled by the temperature control dial. The driver can select one of the 31 levels.

► Auto control

When pressing the AUTO switch, "AUTO" is shown on the display and the fan speed and air distribution mode are adjusted automatically to keep interior temperature to the set temperature. In full AUTO mode, the FATC receives various signals such as the indoor temperature, ambient temperature, engine coolant temperature, sunlight, from different sensors to control the A/C compressor, mode actuator, intake actuator, temp actuator, blower motors, etc. to keep indoor environments fresh.

► Max. cooling/heating control (AUTO mode)

If the temperature is set to the lowest level (Lo) or highest level (Hi), the system will go into the maximum cooling or maximum heating mode regardless of the sensor signals.

Set temp.	A/C compressor	Air outlet (mode)	Air inlet	Blower voltage	Temp actuator
LO	ON	Vent	Recirculation	10.5 V	Max. cooling position
HI	OFF	Footwell	Fresh air	10.5 V	Max. heating position

Modification basis	
Application basis	
Affected VIN	

(3) Blower control

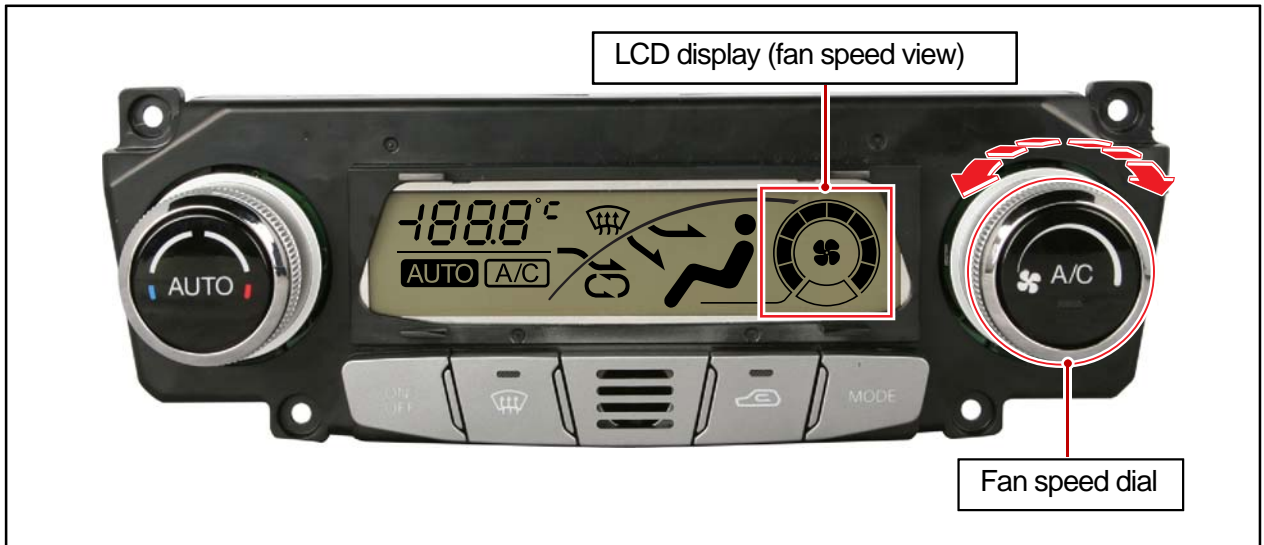

In AUTO mode, the blower motor is controlled automatically according to the set temperature and the blower motor speed can also be controlled manually. The fan speed can be checked via the LCD display.

► **Manual control**

Blower step	Blower motor voltage (V)
1	4.0
2	5.0
3	6.0
4	7.0
5	8.0
6	9.0
7	10.5
8	VIGN

Turn the fan speed dial to control the blower motor manually. The fan speed increments by 1 level per revolution of the dial. (allowance: ± 0.5 V)

► **Auto control**

In AUTO mode, the fan speed is automatically controlled depending on the set temperature and surrounding environment and the blower motor operates steplessly.

► **Control for defrosting**

When the defrost mode is selected with the blower dial in AUTO position, the blower motor voltage is increased by 1.5 V compared to the AUTO control voltage for a certain amount of time.

► **Sun load compensation control**

The system increases the fan speed by adding up 2.5 V of voltage in direct sunlight.

Modification basis	
Application basis	
Affected VIN	

► Initial fan speed control for cooling/heating

- Cooling start control

When the intake temperature sensor indicates over 35°C, the driver might feel uncomfortable by the air flow from the vent. Therefore, at the initial operation stage, the hot air is discharged to the windshield (DEF mode) for about 5 seconds.

- Heating start control

When the engine coolant temperature is low or the wind temperature is not warmed up sufficiently, the driver might feel uncomfortable by the air flow from the vent. Therefore, the fan speed is set to the 1st stage and the cool air is sent to the windshield until the coolant temperature increases to the proper level (DEF mode). As the engine coolant temperature goes up, the mode is changed to Defrost & Foot mode or AUTO mode to increase the speed of blower motor. This control is cancelled when the output value of the water temperature sensor is approximately 62°C. However, the control time must not exceed 10 minutes.

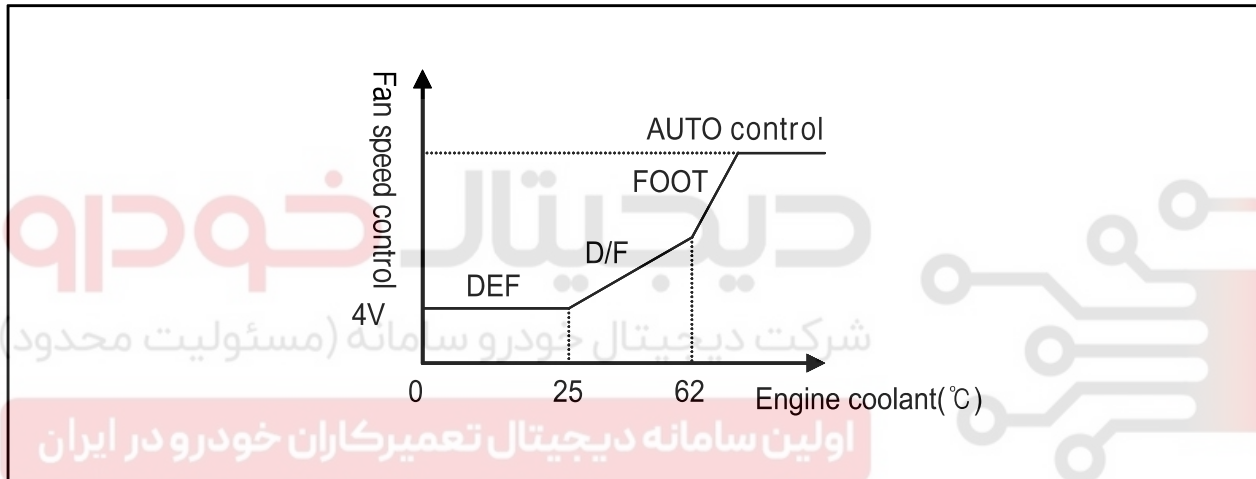

Modification basis	
Application basis	
Affected VIN	

(4) Air source control

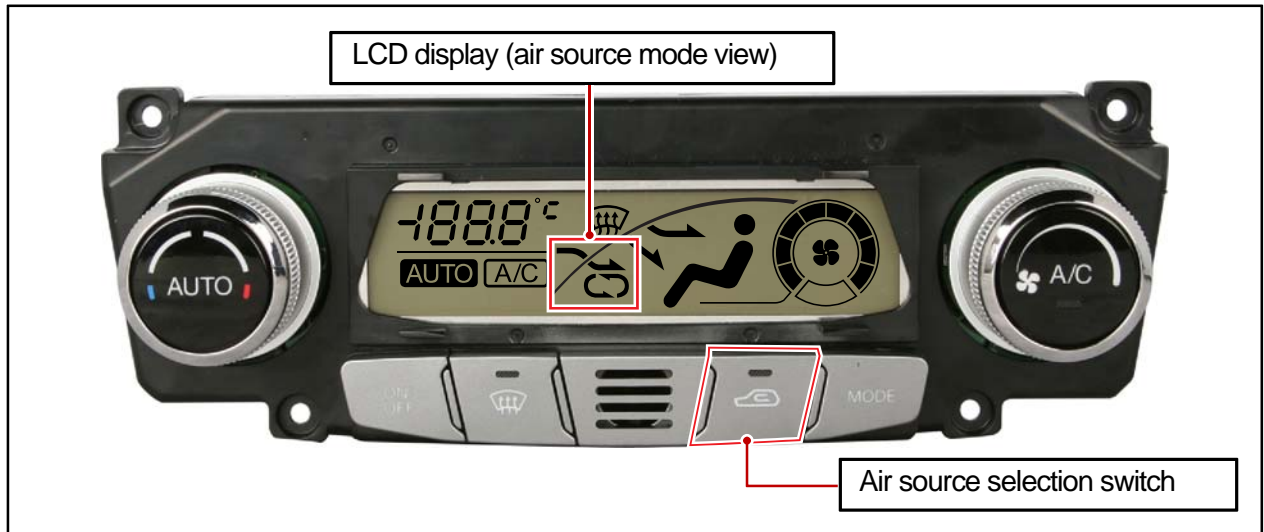

The air source selection is made by the intake actuator. The driver can see the air source mode through the switch's indicator and the LCD display.

► Manual control

Press the air source selection switch to control the air source selection door manually. The air source mode is switched between the fresh air and recirculation alternatively each time the switch is pressed.

► Auto control

In auto mode, the basic setting for the air source is fresh air. When the ambient temperature is high during cooling, the air source is changed from fresh air to recirculation to lower the temperature.

► Control by vehicle speed (heating)

The air source selection is controlled in accordance with the vehicle speed while driving. Operating conditions and control process are as follows:

- AUTO mode
- When the vehicle speed is 45 km/h or lower in fresh air mode, the air source door is open 30% of its maximum opening. If the vehicle speed is 65 km/h or more, then the air source door is completely open.



NOTE

However, the ambient temperature should be 0°C or less, coolant temperature 62°C or less and the electric fan 7.5V or higher.

Modification basis	
Application basis	
Affected VIN	

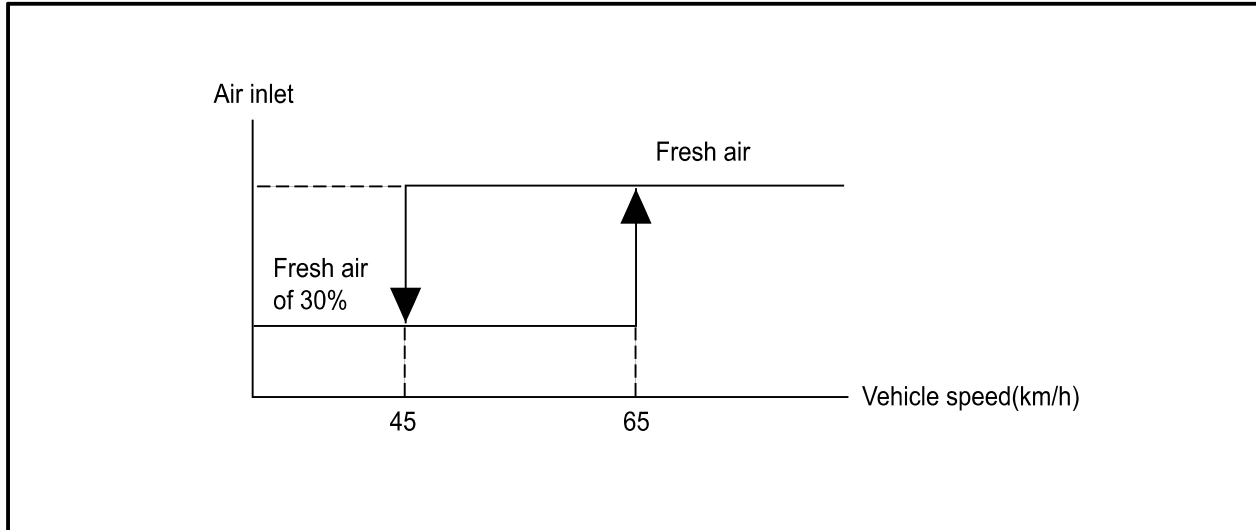

دیجیتال خودرو

شرکت دیجیتال خودرو سامانه (مسئولیت محدود)

اولین سامانه دیجیتال تعمیرکاران خودرو در ایران



Modification basis	
Application basis	
Affected VIN	

(5) Air distribution control

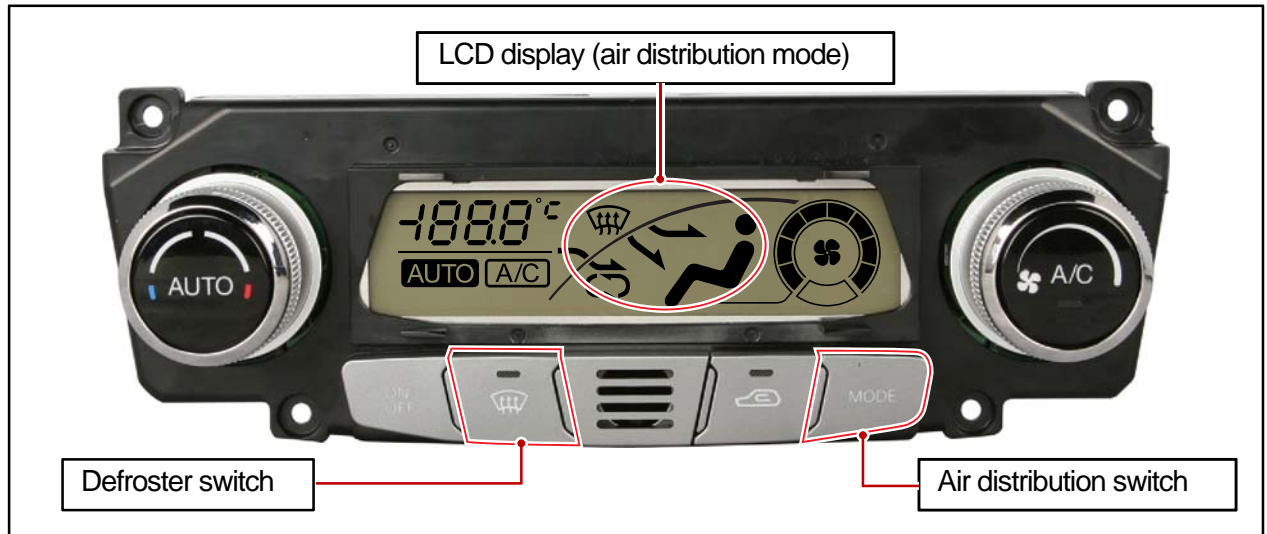

The air distribution is changed by the mode actuator and the LCD display and the indicator of the defroster switch shows which air distribution modes is selected.

► Manual control

The driver can select one of 5 air distribution mode using the air distribution switch and defroster switch.

- Defroster switch: When this switch is pressed, the defroster mode (A/C ON, fresh air mode, fan speed of 1 level or above) is activated. Pressing the switch again returns the unit to the previous status.
- Air distribution switch: The mode is switched in the following order each time the switch is pressed: Vent mode→Bi-level mode→Foot mode→Defroster & Foot mode.

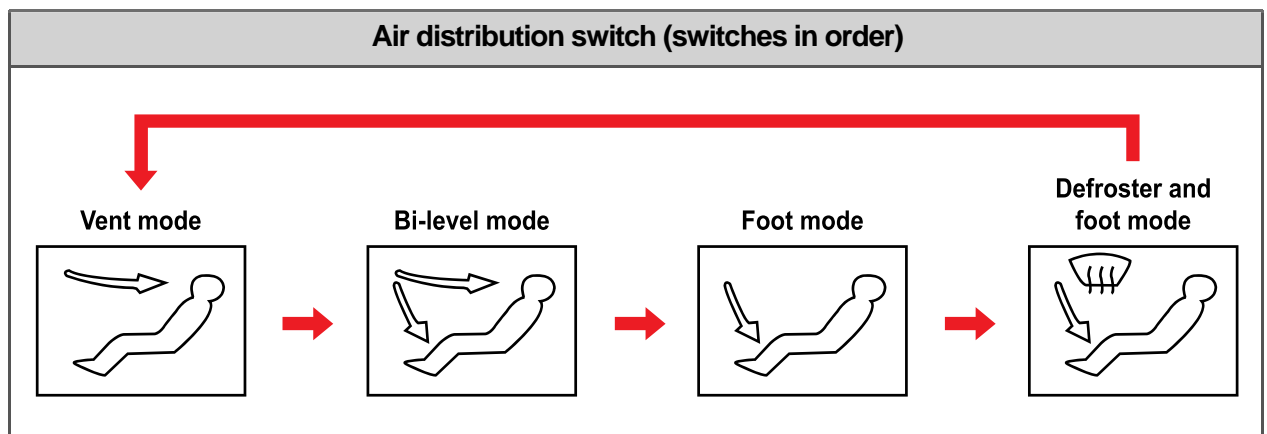

NOTE

When the defroster switch is pressed with the fan speed 0, the fan speed will be set to level 2 automatically.

Modification basis	
Application basis	
Affected VIN	

► Auto control

The air flow mode is controlled automatically in accordance with the vehicle indoor conditions. But it is controlled as described below during initial driving (after overnight parking) in cold weather:

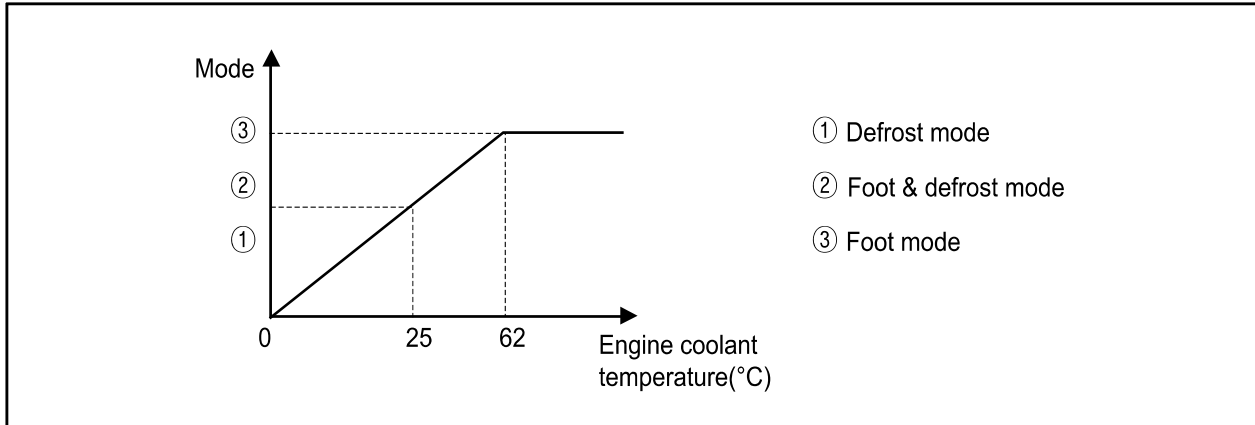

دیجیتال خودرو

شرکت دیجیتال خودرو سامانه (مسئولیت محدود)

اولین سامانه دیجیتال تعمیرکاران خودرو در ایران



Modification basis	
Application basis	
Affected VIN	

(6) A/C control

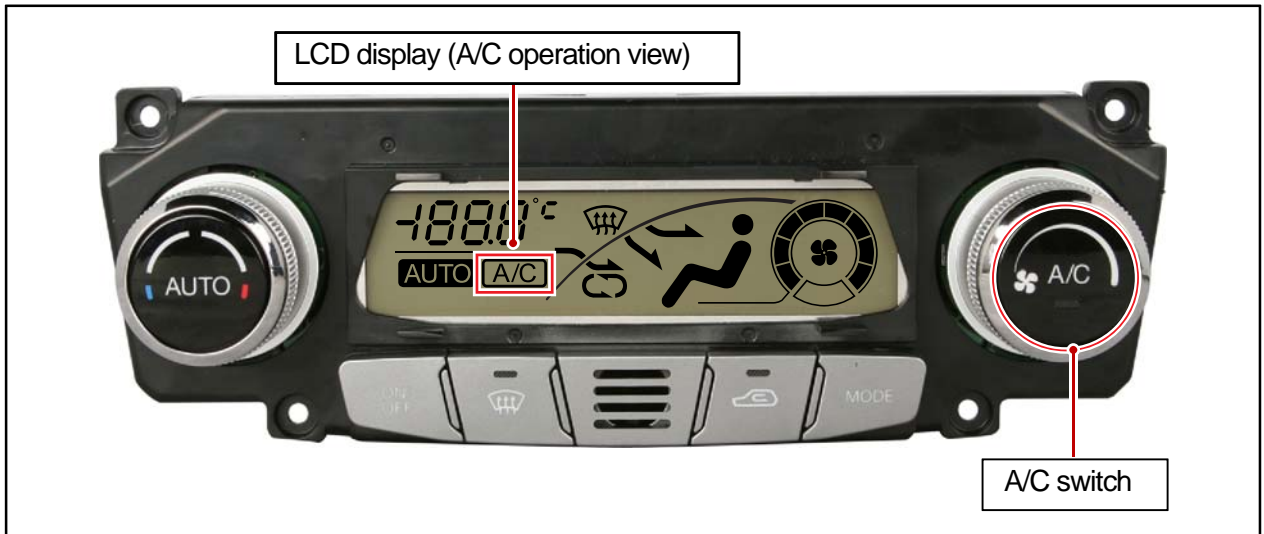

The air conditioner is controlled by the A/C compressor of the engine ECU according to the signal from the heater and A/C control assembly. The driver can see the air conditioner operation through the LCD display and the indicator of the A/C switch.

► **Manual control**

Pressing the A/C switch or selecting defrost mode turns on the A/C.

► **Auto control**

The A/C is controlled in accordance with the indoor temperature and ambient temperature.

If the intake sensor detects the freezing of the evaporator or the ambient temperature is low (2°C or below) in winter, the compressor is turned off to protect the A/C compressor.

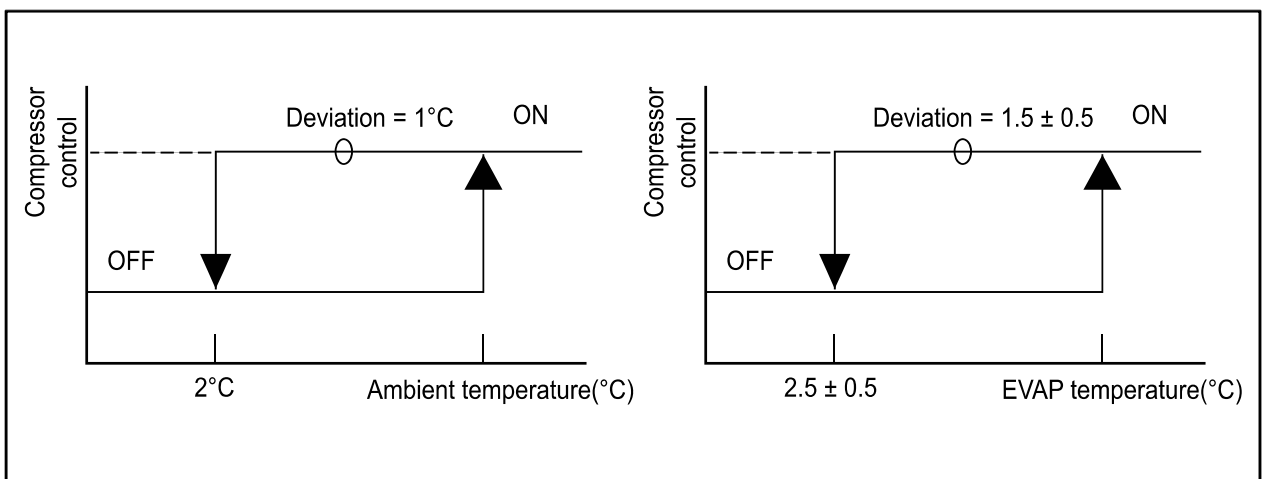

Modification basis	
Application basis	
Affected VIN	

(7) Self-diagnosis

The FATC has a self-diagnosis function that can diagnose the system by itself. If this system is defective, the LCD display shows the diagnostic trouble code (DTC) to inform a driver of defects on the device such as a sensor or actuator. The driver can see the each sensor data on the air conditioning system after entering self-diagnosis mode. Before checking each component, be sure to check the default code by using self diagnosis function.

► **Diagnostic trouble code**



Code	Defective part
00	Normal
21	Ambient temperature sensor
22	Incar sensor
23	Water temperature sensor
24	Intake sensor
26	Temp door (control)
31	Mode door (vent)
32	Mode door (bi-level)
33	Temp door (cool)
34	Mode door (foot)
35	Mode door (defroster & foot)
36	Mode door (defroster)
37	Intake door (fresh air)
38	Intake door (1/3)
39	Intake door (recirculation)

Diagnostic trouble code

Open circuit in sensor

Diagnostic trouble code

NOTE

The diagnostic trouble code (DTC) flashes twice and is displayed repeatedly in order as long as a separate operation is not performed.

Modification basis	
Application basis	
Affected VIN	

► How to enter self-diagnosis

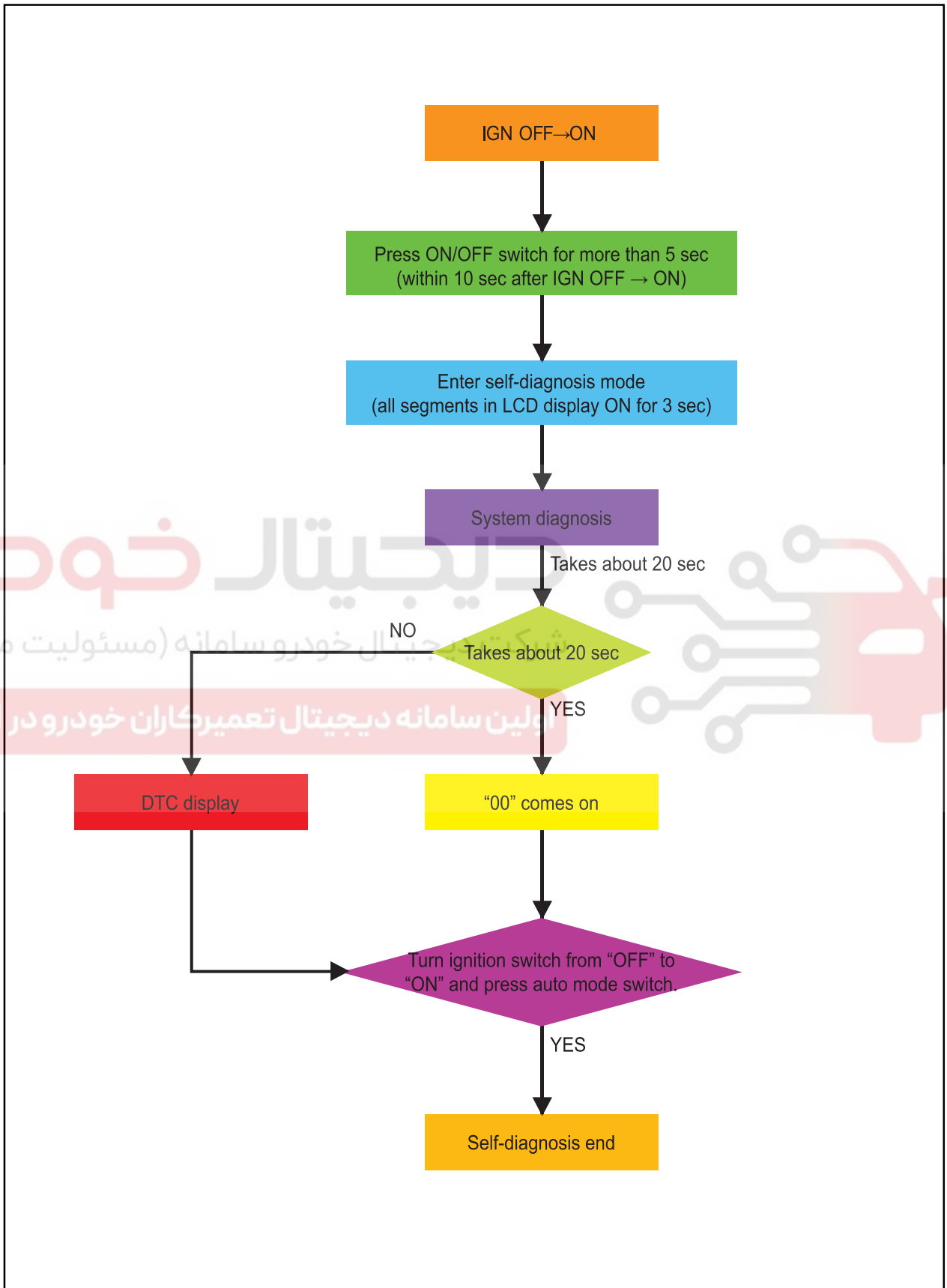

AIR
CONDITIO
AIR BAG
SEAT
SUNROO
F
BODY
INTERIOR
BODY
EXTERIO
BODY
REPAIR

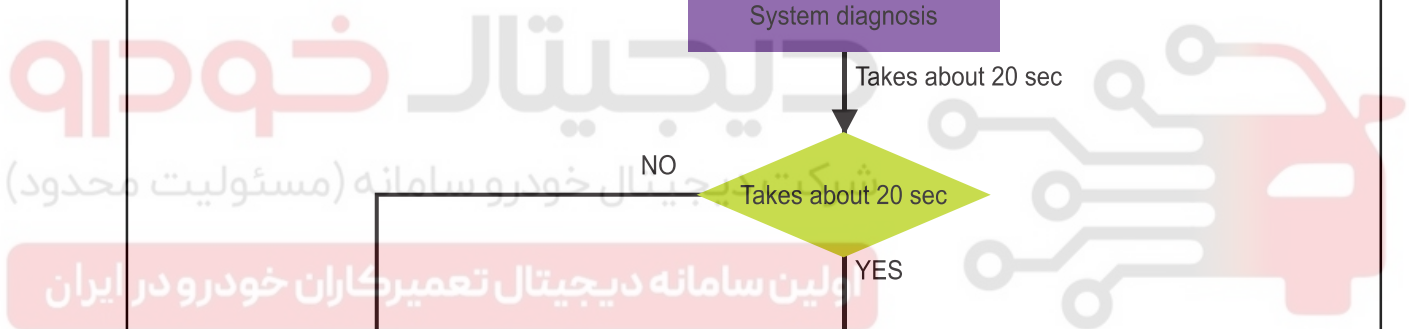

Modification basis	
Application basis	
Affected VIN	

1. If the ON/OFF switch of the FATC is pressed for more than 5 seconds within 10 seconds after turning the ignition key from the "OFF" position to the "ON" position, all the segments in LCD display comes on for 3 seconds.

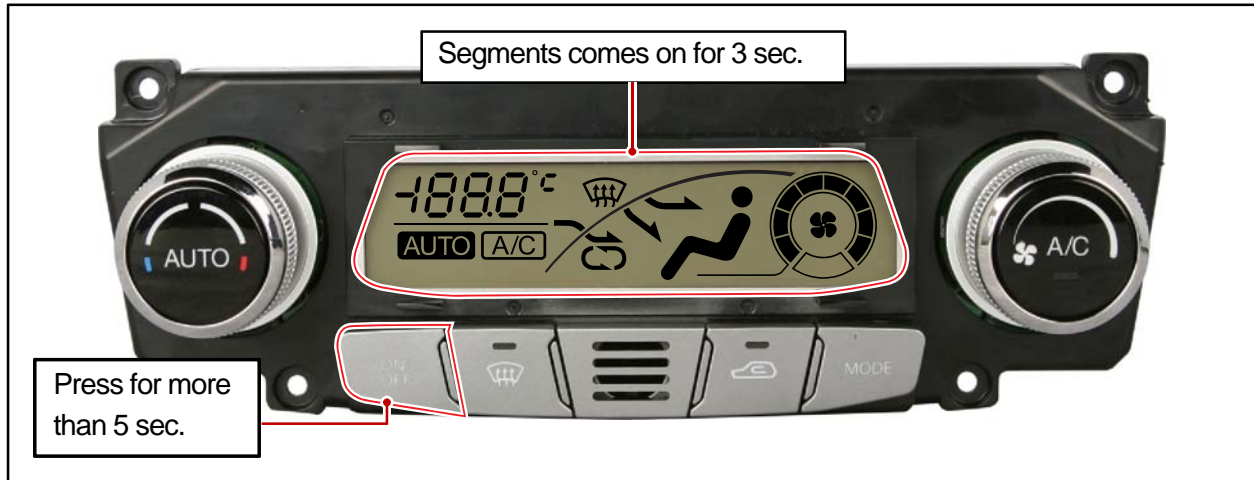

2. The LCD display shows "2" and starts to check the sensor and actuator in the air conditioning system automatically.



3. After about 20 seconds, the LCD display shows whether there is fault. ("00" for normal)



4. The self diagnosis ends when turning the ignition key from the "OFF" position to the "ON" position or pressing the AUTO mode switch.

Modification basis	
Application basis	
Affected VIN	

► Sensor data check

1. This mode can be entered when the temperature control dial is turned clockwise (1 click or more) at any time after entering self-diagnosis mode, and the LCD display shows "51".



2. The values for each sensor are shown in sequence on the LCD display each time the defroster switch is pressed.

51

→ Ambient temperature sensor

→ Incar sensor

→ Intake sensor

→ Water temperature sensor

→ Sun sensor

NOTE
The value of the sun load sensor is displayed after being converted to one tenth.

3. When the temperature control dial is turned anti-clockwise, the menu returns to status when entering self-diagnosis mode.

Modification basis	
Application basis	
Affected VIN	

4. MTC SYSTEM OPERATION PROCESS

1) Input/Output Factors

The MTC (Manual Temperature Control) system controls all the actuator and blower motor by the driver. The heater and A/C control assembly with MTC has the dials and switches with the indicators so that the driver can know the air conditioning system's operation.

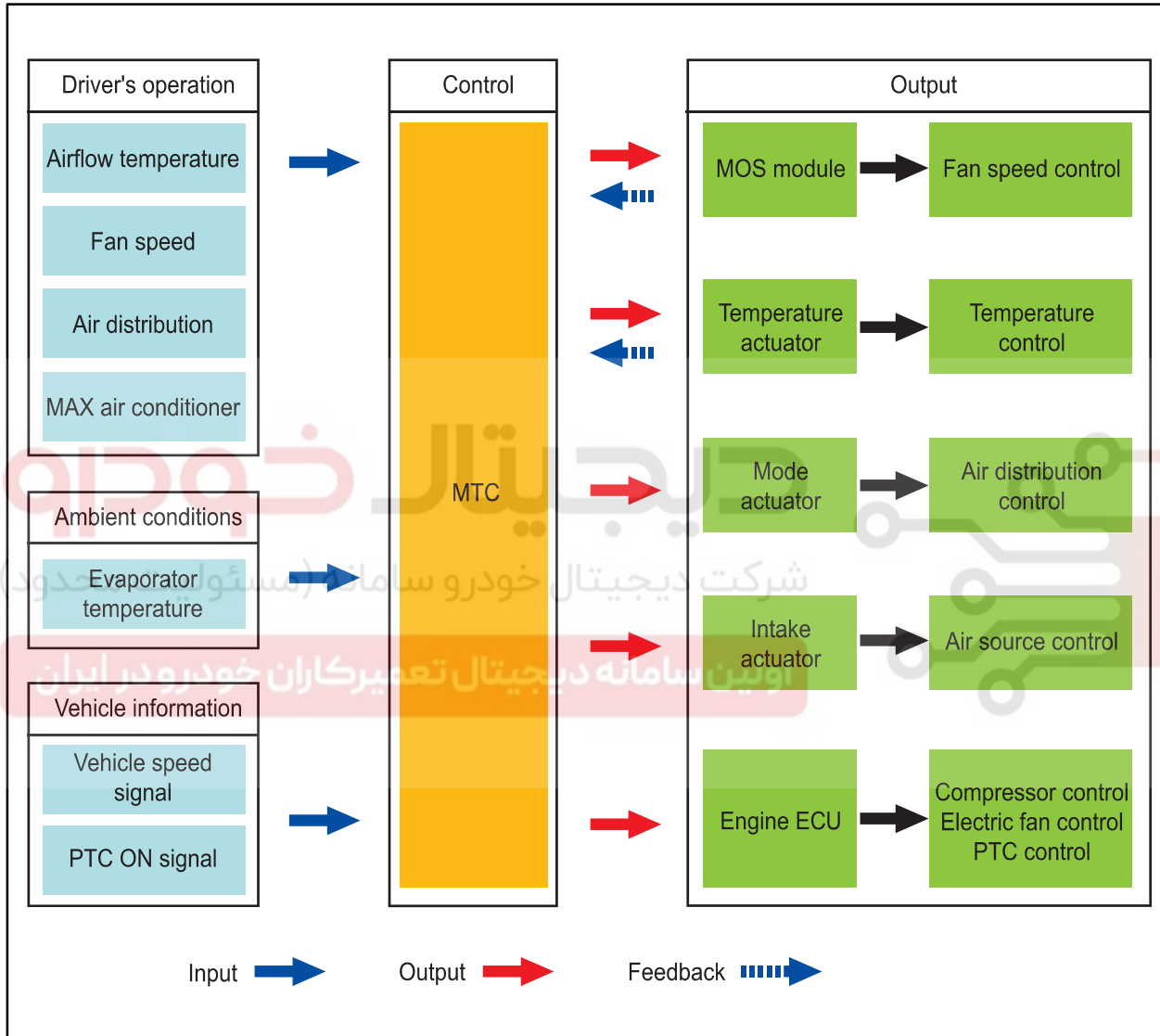

Modification basis	
Application basis	
Affected VIN	

2) Function

(1) Function of heater and A/C control assembly with MTC

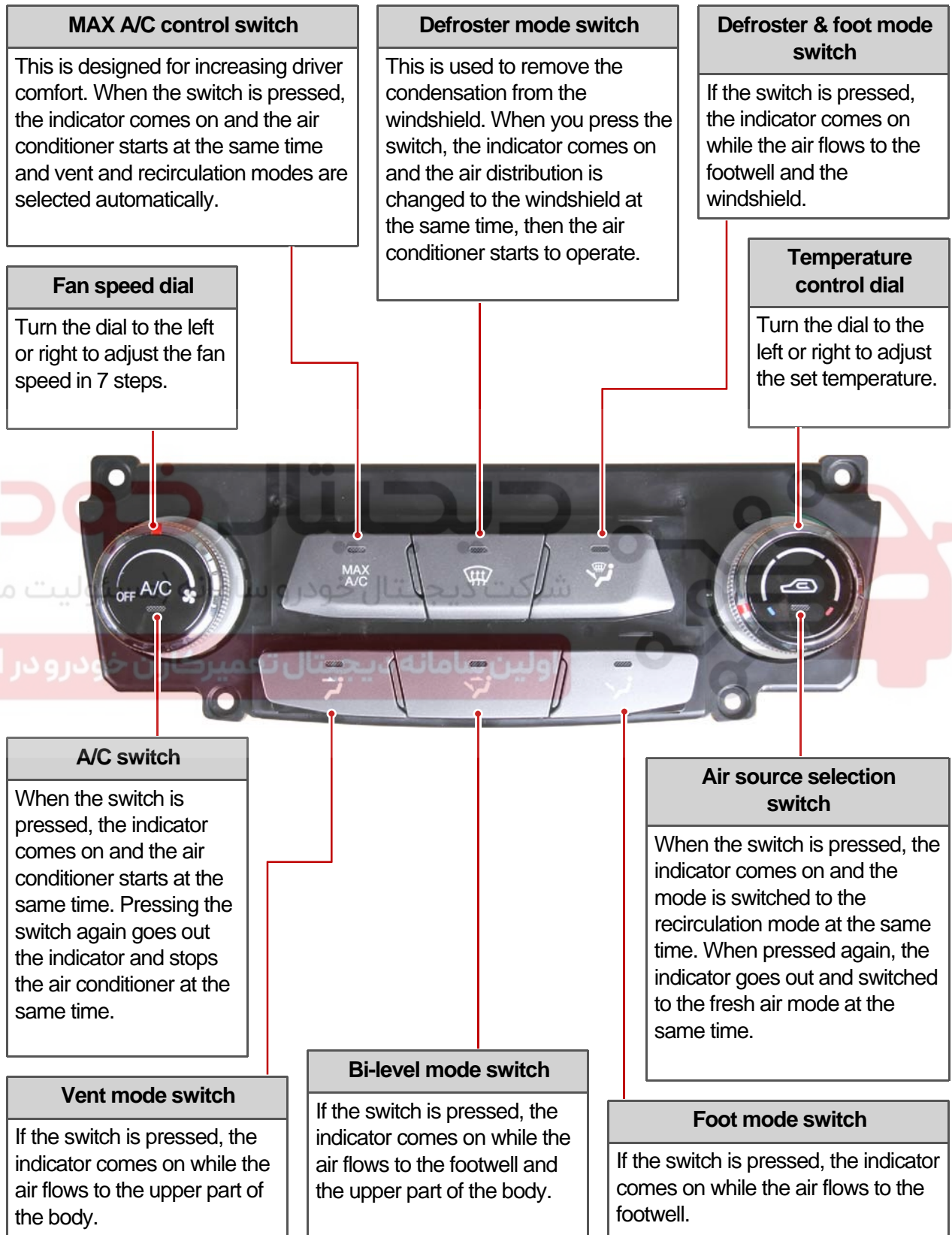

Modification basis	
Application basis	
Affected VIN	

(2) Temperature control



The temp actuator controls the temperature of air discharged depending on the temperature control dial operation by the driver. The driver can select one of the 17 levels.

(3) Blower control



Blower step	Blower motor voltage (V)
1	4.0
2	5.0
3	6.0
4	7.5
5	9.0
6	10.5
7	VIGN

The fan speed increments by 1 level per revolution of the fan speed dial. (allowance: ± 0.5 V)

Modification basis	
Application basis	
Affected VIN	

(4) Air source control



When pressing the air source selection switch, the air source mode is changed via the intake actuator's operation. The air source mode is switched between the fresh air and recirculation alternatively each time the switch is pressed. You can see the air source mode through the switch's indicator. (the indicator comes on at recirculation mode)

► **Control by vehicle speed**

The air source selection is controlled in accordance with the vehicle speed while driving. Operating conditions and control process are as follows:

- When the PTC heater operates at fresh air mode in winter
- When the vehicle speed is 45 km/h or lower in fresh air mode, the air source door is open 30% of its maximum opening. If the vehicle speed is 65 km/h or more, then the air source door is completely open.

NOTE

However, the electronic fan should be more than 7.5 V.

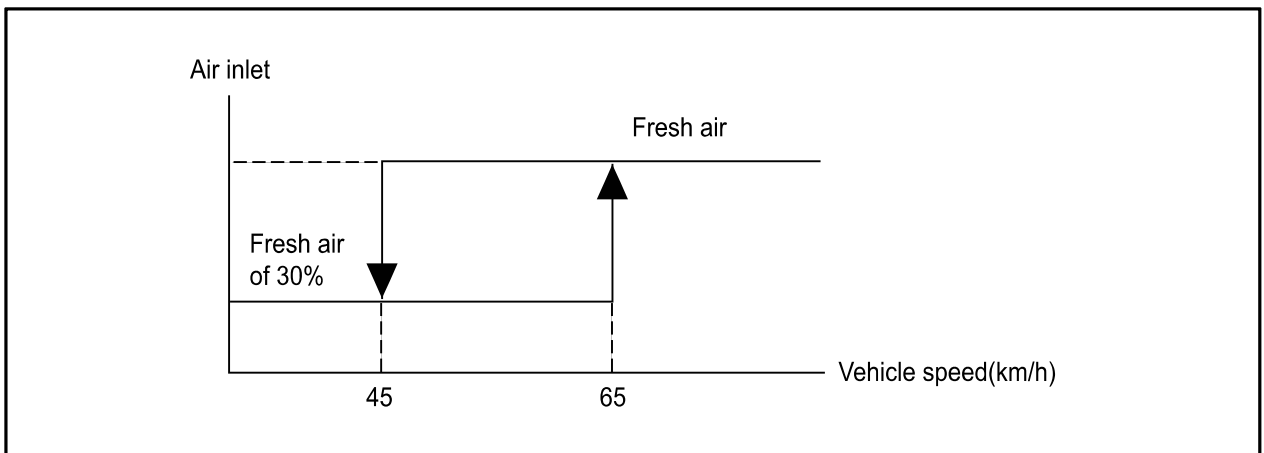

Modification basis	
Application basis	
Affected VIN	

(5) Air distribution control

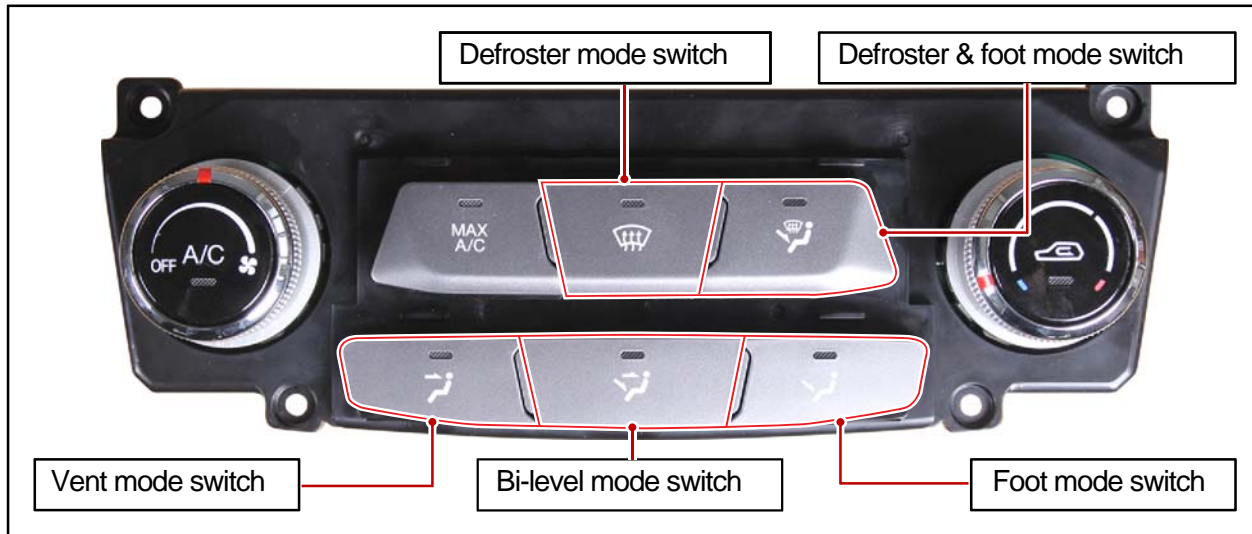

The driver can select one of 5 air distribution modes using the 5 air distribution switches in the center of the MTC. The selected air distribution mode is changed by the mode actuator and acknowledged by the indicator for each switch coming on.

► **Vent mode**

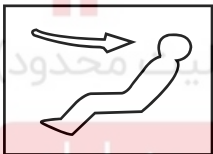

If the vent mode switch is pressed, the indicator comes on while the air flows to the upper part of the body.

► **Bi-level mode**

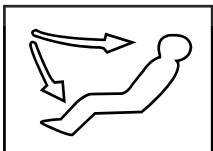

If the bi-level mode switch is pressed, the indicator comes on while the air flows to the footwell and upper part of the body.

► **Foot mode**

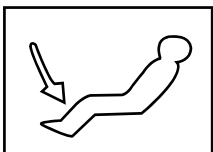

If the foot mode switch is pressed, the indicator comes on while the air flows to the footwell.

Modification basis	
Application basis	
Affected VIN	

► Defroster & foot mode

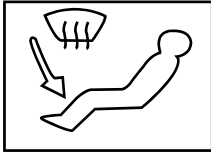

If the defroster & foot mode switch is pressed, the indicator comes on while the air flows to the footwell and the windshield.

► Defroster mode

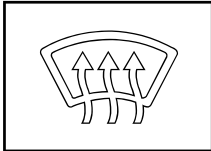

This is used to remove the condensation from the windshield. When you press the switch, the indicator comes on and the air distribution is changed to the windshield at the same time, then the air conditioner starts to operate.

دیجیتال خودرو

شرکت دیجیتال خودرو سامانه (مسئولیت محدود)

اولین سامانه دیجیتال تعمیرکاران خودرو در ایران



Modification basis	
Application basis	
Affected VIN	

(6) A/C control



The air conditioner is operated at the defroster mode and MAX air conditioner mode and when the A/C switch is turned to "ON" position. It is controlled by the A/C compressor of the engine ECU according to the signal from the heater and A/C control assembly. The driver can see that the A/C has been activated when an indicator lamps at the A/C switch and MAX A/C switch comes on. If the intake sensor detects the freezing of the evaporator core, it stops the air conditioner by turning off the compressor.

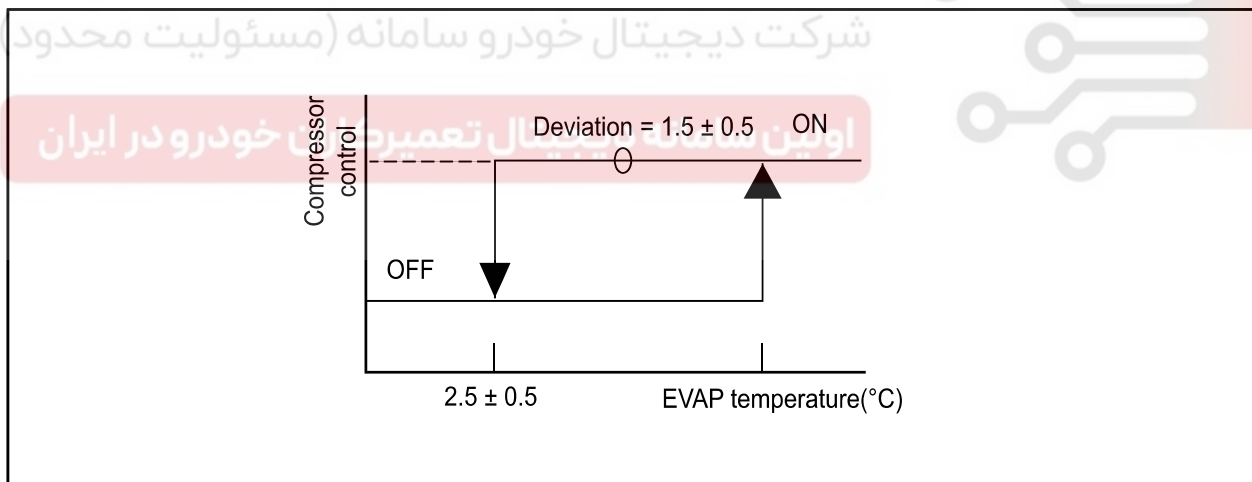

► MAX A/C control

This is designed for increasing driver comfort. When the switch is pressed, the air conditioner is operated and vent and recirculation modes are selected automatically. The discharge temperature and fan speed are regulated depending on the driver's choice.

Modification basis	
Application basis	
Affected VIN	

5. PTC HEATER OPERATION PROCESS

The engine ECU controls the PTC (Positive Temperature Coefficient) heater system by adjusting the power supplied to the PTC system according to the two measured temperature values from the engine coolant temperature sensor and HFM sensor. This system is mounted to the heater air outlet in the air condition system module and heats the air which flows to the passenger room. Since the PTC system is heated by the electrical power, the electric load and alternator capacity is greater than the conventional one. The PTC is not operated when a) the engine is cranking, b) the battery voltage is below 11 V, c) the glow plug is being preheated.

1) PTC Heater Input/Output Factors

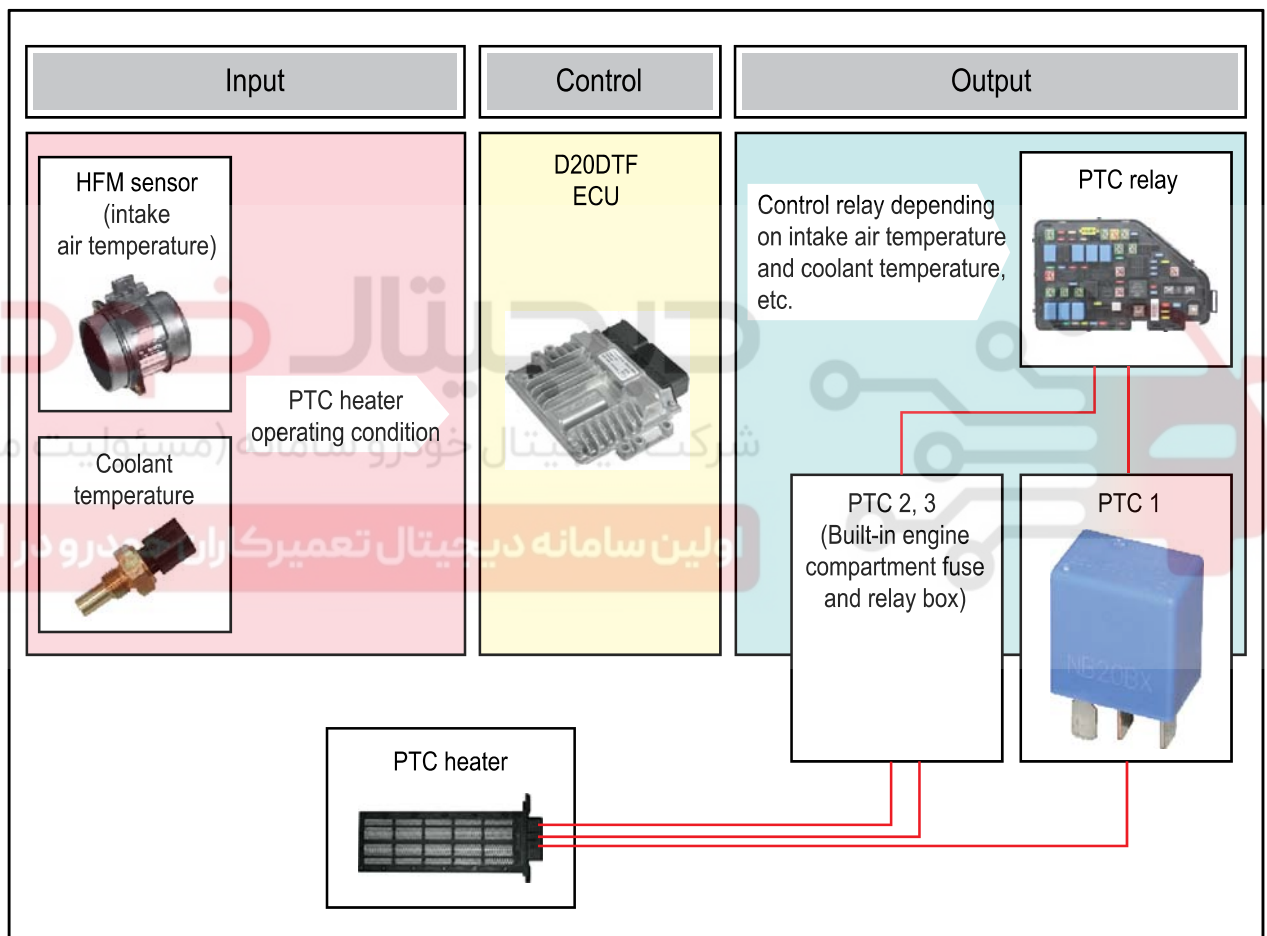

The ceramic PTC features that the resistance rises quickly in a certain temperature range. The PTC heater has 3 circuits with power of 330 W. While only 1 circuit in the PTC heater is connected during PTC1 operation, 2 circuits are connected during PTC2 or PTC3 operation.

The PTC heater operates as follows: temperature rises above specified level → resistance increases → current decreases → calorific value decreases → temperature drops → resistance increases → current increases → temperature rises.

Modification basis	
Application basis	
Affected VIN	

AIR CONDITIONING
 AIR BAG
 SEAT
 SUNROOF
 BODY INTERIOR
 BODY EXTERIOR
 BODY REPAIR

2) Control Condition For PTC Heater

Operation	Operating condition	PTC heater status
HI mode operation (PTC2, 3)	- Coolant temperature < 15°C	PTC heater operates in "HIGH" mode if operating conditions are met
LO mode operation (PTC1)	- Coolant temperature 15°C ≤ 65°C and intake temperature ≤ -10°C - Coolant temperature 15°C < 65 ~ 60°C and intake temperature < -10°C ~ 0°C - Coolant temperature 15°C ≤ 65°C and intake temperature ≤ 0°C ~ 5°C	PTC heater operates in "LOW" mode if operating conditions are met
Conditions for deactivating	- Air conditioner blower switch OFF - When the ambient temperature sensor is faulty (short or open circuit in the wiring) - Engine is cranking - Battery voltage is 11 V or less - Glow plug is being preheated (Glow indicator comes on)	

► Conditions for PTC heater "LOW" operation mode (2nd step)

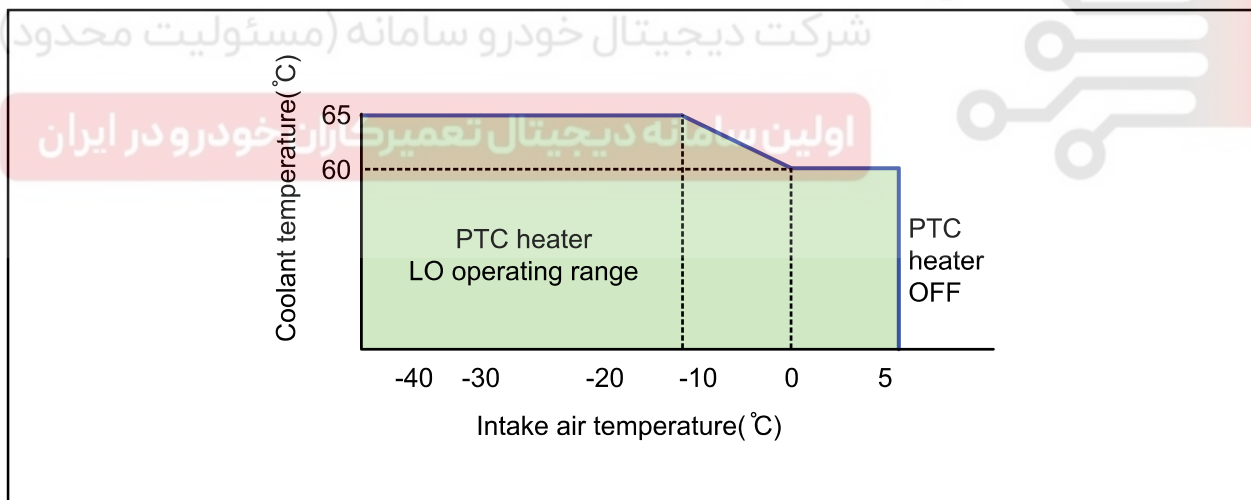

Modification basis	
Application basis	
Affected VIN	

6. CIRCUIT DIAGRAM

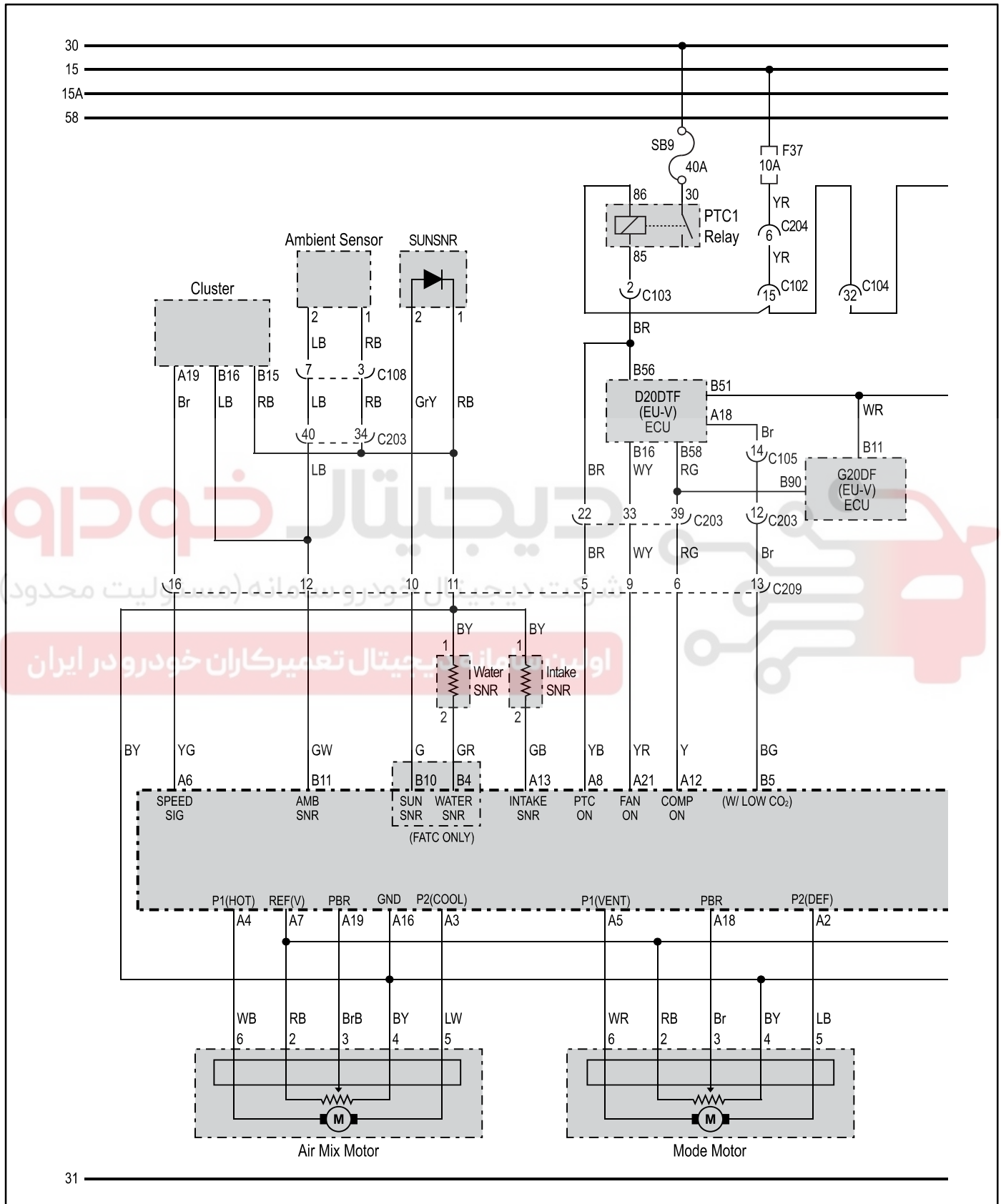

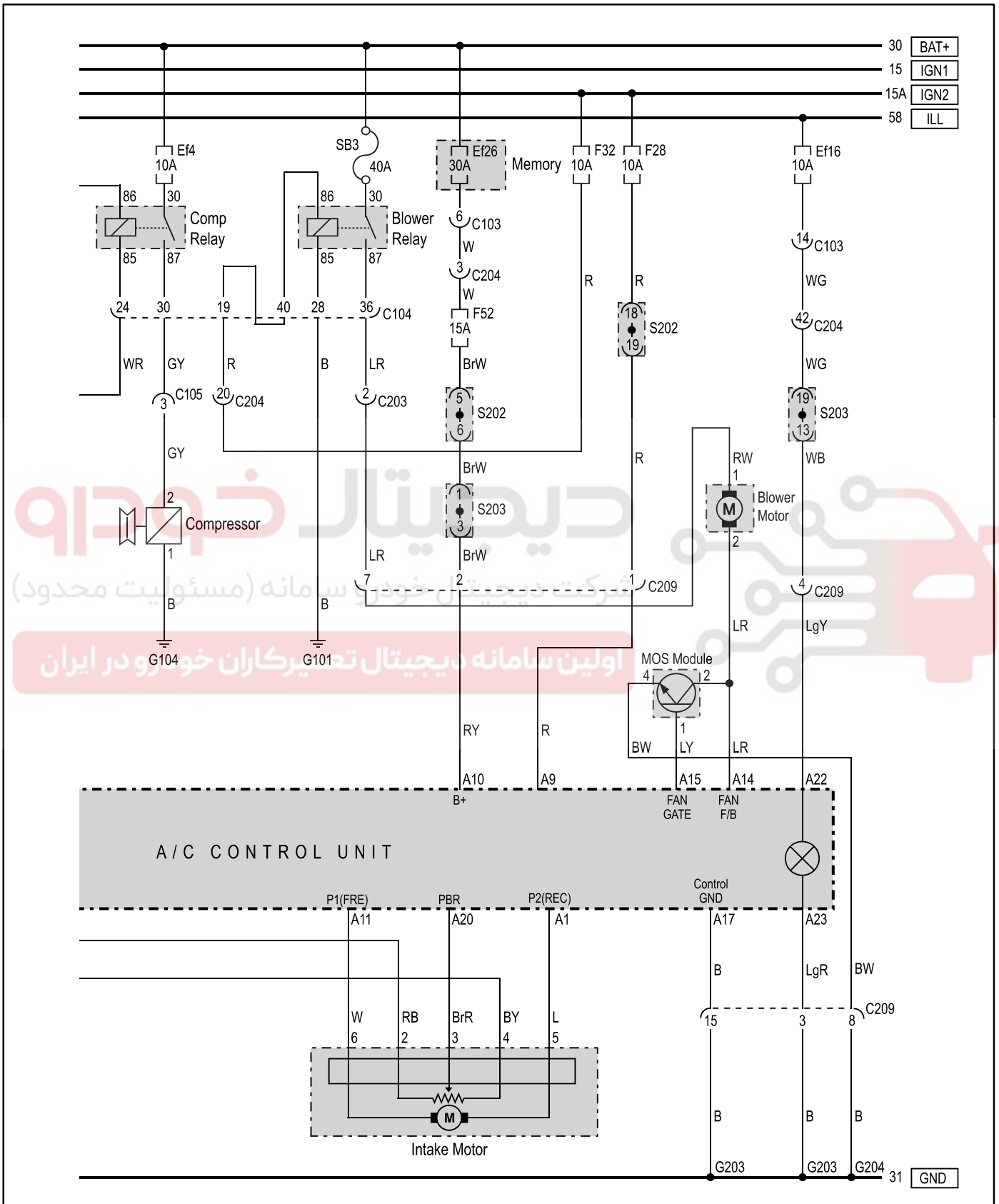

دیجیتال خودرو
شرکت دیجیتال خودرو سامانه (مسئولیت محدود)
اولین سامانه دیجیتال تعمیرکاران خودرو در ایران

Modification basis	
Application basis	
Affected VIN	

CONFIGURATION AND FUNCTIONS

6810-00 AIR CONDITIONER MODULE

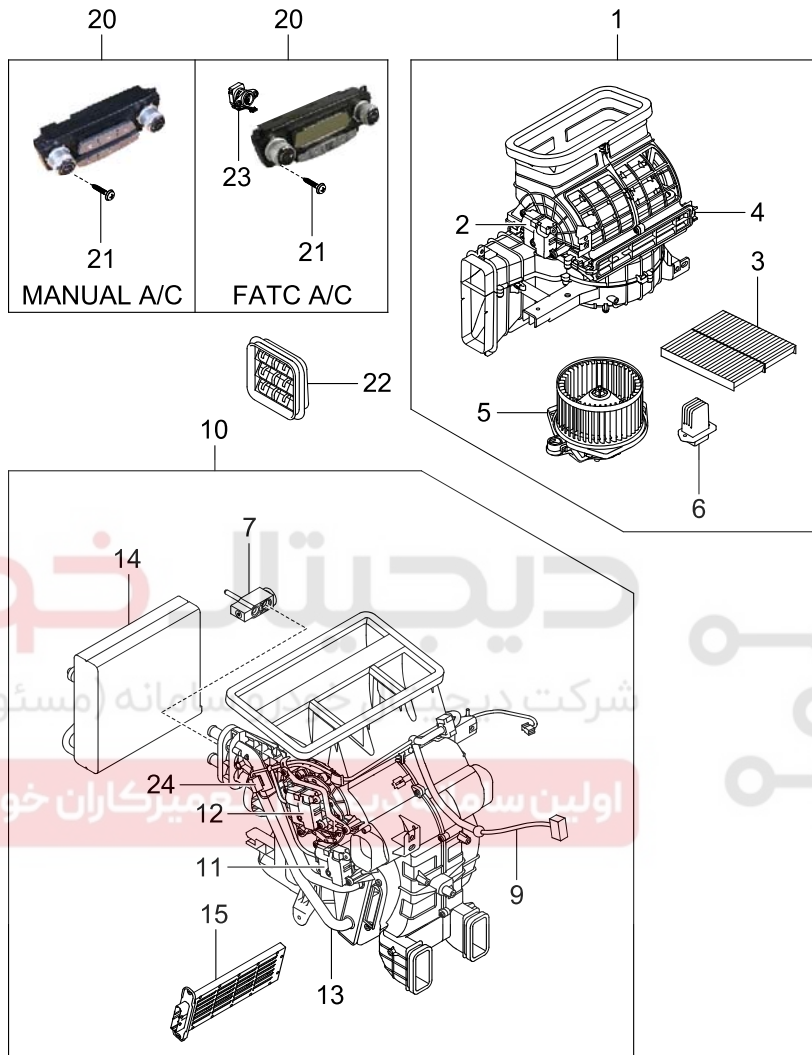

- 1. Blower assy
- 2. Intake actuator assy
- 3. Air filter assy
- 4. Air filter cover
- 5. Blower motor assy
- 6. MOS module
- 7. Expansion valve assy
- 9. Heater & evaporator wiring assy
- 10. Heater & evaporator assy
- 11. Temperature actuator assy
- 12. Mode actuator assembly
- 13. Heater core assy
- 14. Evaporator core
- 15. PTC heater assy
- 20. Heater & A/C control assy
- 21. Screw
- 22. Ventilation insert assy
- 23. In-car sensor motor
- 24. Intake sensor

Modification basis	
Application basis	
Affected VIN	

S.G.N.

6820-00 AIR CONDITIONER HOSE AND PIPE

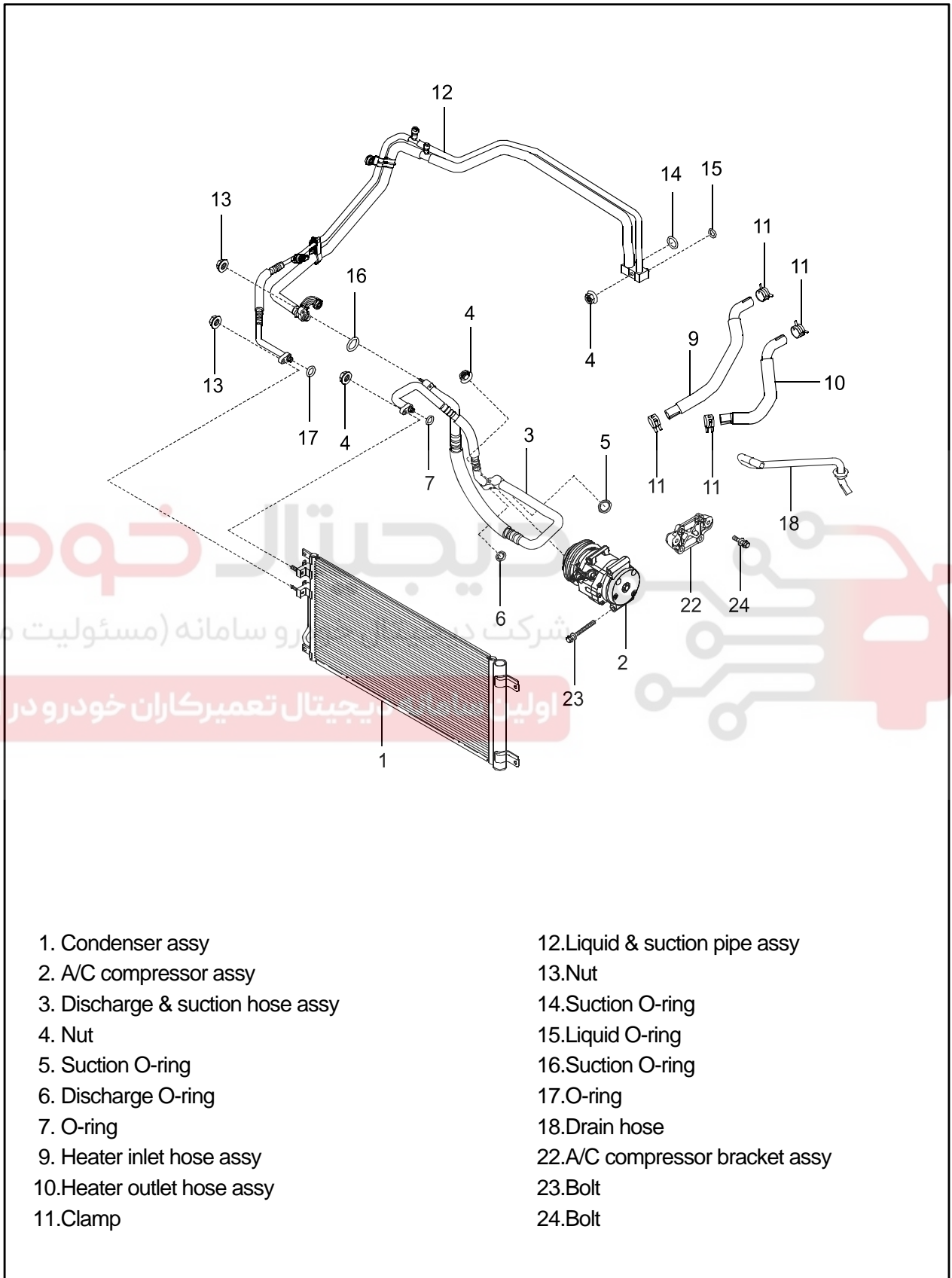

- | | |
|----------------------------------|---------------------------------|
| 1. Condenser assy | 12. Liquid & suction pipe assy |
| 2. A/C compressor assy | 13. Nut |
| 3. Discharge & suction hose assy | 14. Suction O-ring |
| 4. Nut | 15. Liquid O-ring |
| 5. Suction O-ring | 16. Suction O-ring |
| 6. Discharge O-ring | 17. O-ring |
| 7. O-ring | 18. Drain hose |
| 9. Heater inlet hose assy | 22. A/C compressor bracket assy |
| 10. Heater outlet hose assy | 23. Bolt |
| 11. Clamp | 24. Bolt |

Modification basis	
Application basis	
Affected VIN	

S.G.N. 6830-00 AIR DISTRIBUTOR

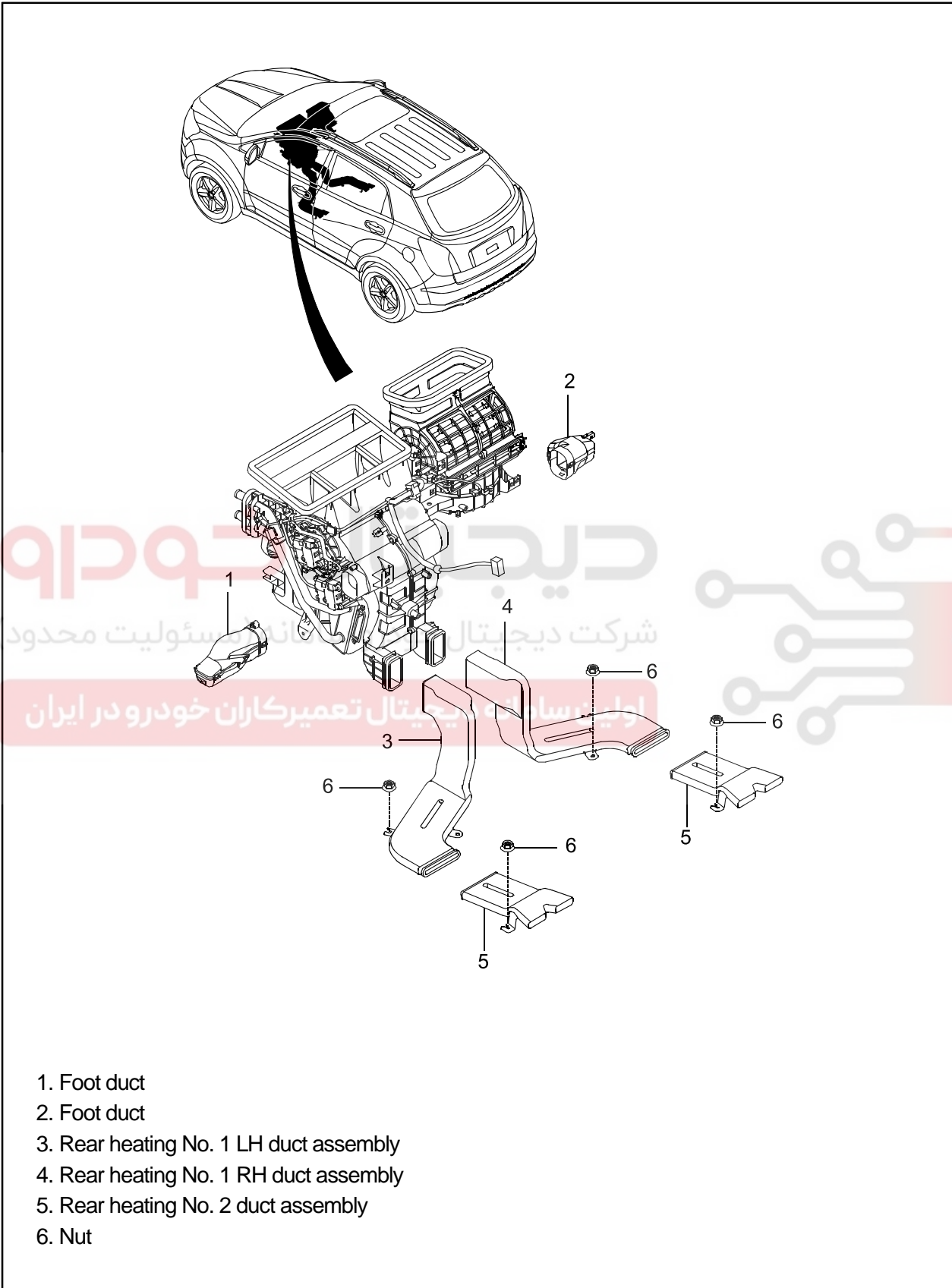

- 1. Foot duct
- 2. Foot duct
- 3. Rear heating No. 1 LH duct assembly
- 4. Rear heating No. 1 RH duct assembly
- 5. Rear heating No. 2 duct assembly
- 6. Nut

Modification basis	
Application basis	
Affected VIN	

S.G.N.

6810-20 HEATER AND A/C CONTROL ASSEMBLY

1) Overview

The heater and A/C control assembly falls in to two categories; FATC (Full Automatic Temperature Control) and MTC (Manual Temperature Control), which controls the air conditioning system's operation.

2) Mounting Location & Components



Heater & A/C control assembly

With FATC	With MTC

Modification basis	
Application basis	
Affected VIN	

Heater & A/C control assembly (with FATC)



- 1. Temperature control dial
- 2. AUTO switch
- 3. LCD display
- 4. Fan speed dial
- 5. A/C switch
- 6. ON/OFF switch
- 7. Defroster mode switch
- 8. Indoor temperature sensing part
- 9. Air source selection switch
- 10. Air distribution switch

Heater & A/C control assembly (with MTC)



- 1. Fan speed dial
- 2. A/C switch
- 3. MAX A/C control switch
- 4. Defroster mode switch
- 5. Defroster & foot mode switch
- 6. Temperature control dial
- 7. Air source selection switch
- 8. Vent mode switch
- 9. Bi-level mode switch
- 10. Foot mode switch

Modification basis	
Application basis	
Affected VIN	

3) Heater & A/C Control Assembly Connector

(1) With FATC

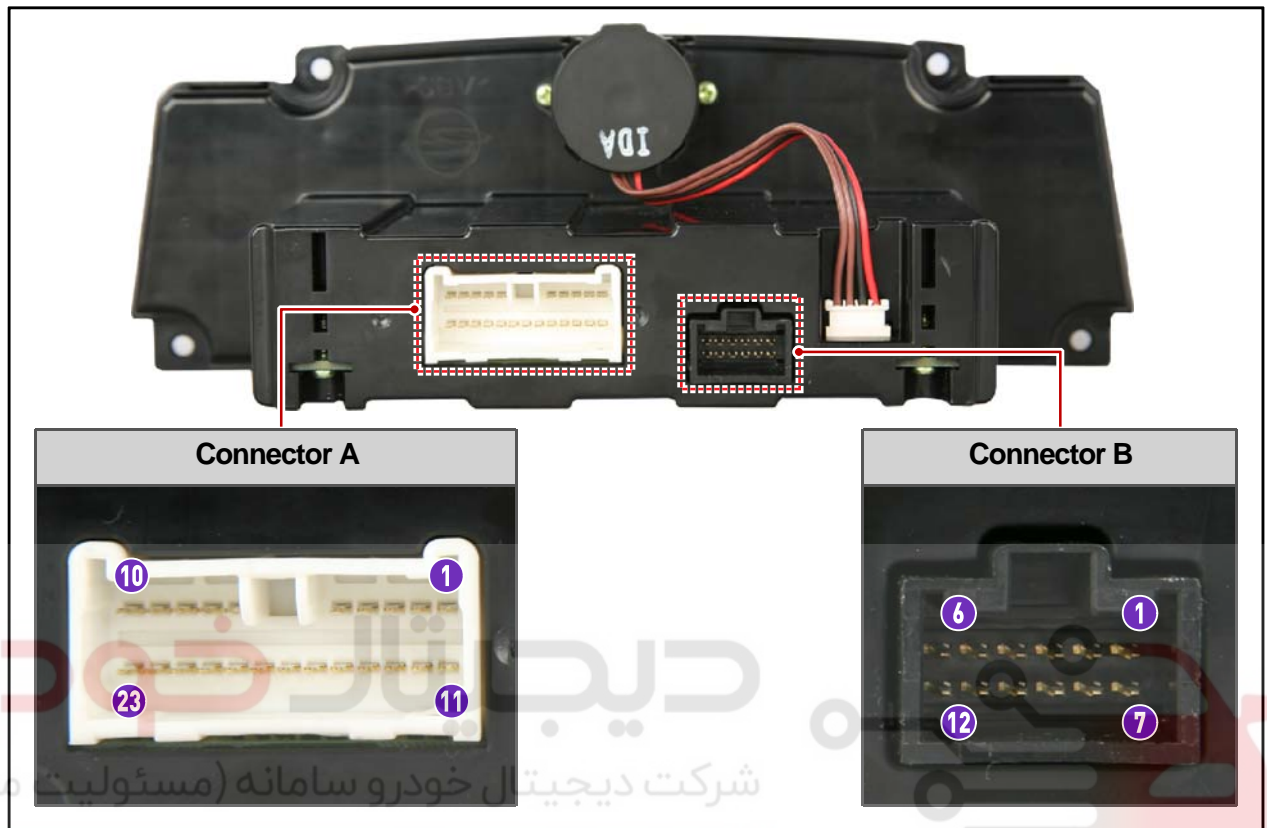

دیجیتال خودرو سامانه (مسئولیت محدود) شرکت دیجیتال خودرو سامانه

اولین سامانه دیجیتال تعمیرکاران ایران

Pin No.	Function
1	Intake actuator (P2)
2	Mode actuator (P2)
3	Temp actuator (P2)
4	Temp actuator (P1)
5	Mode actuator (P1)
6	Vehicle speed signal
7	REF
8	PTC signal
9	IGN +
10	B+
11	Intake actuator (P1)
12	Compressor operation signal

Pin No.	Function
13	Intake sensor signal
14	Blower feedback signal
15	Blower motor control signal
16	Sensor ground
17	Ground
18	Mode actuator position
19	Temp actuator position
20	Intake actuator position
21	Blower operation signal
22	FATC illumination +
23	FATC illumination -

Modification basis	
Application basis	
Affected VIN	

AIR CONDITIONING
AIR BAG
SEAT
SUNROOF
BODY INTERIOR
BODY EXTERIOR
BODY REPAIR

► Connector B

Pin No.	Function
1	-
2	-
3	-
4	Water temperature sensor signal
5	Blower maximum operation signal
6	-
7	-
8	-
9	-
10	Sun-load sensor signal
11	Ambient temperature sensor signal
12	-



شرکت دیجیتال خودرو (مسئولیت محدود)

اولین سامانه دیجیتال تعمیرکاران خودرو در ایران

Modification basis	
Application basis	
Affected VIN	

(2) With MTC

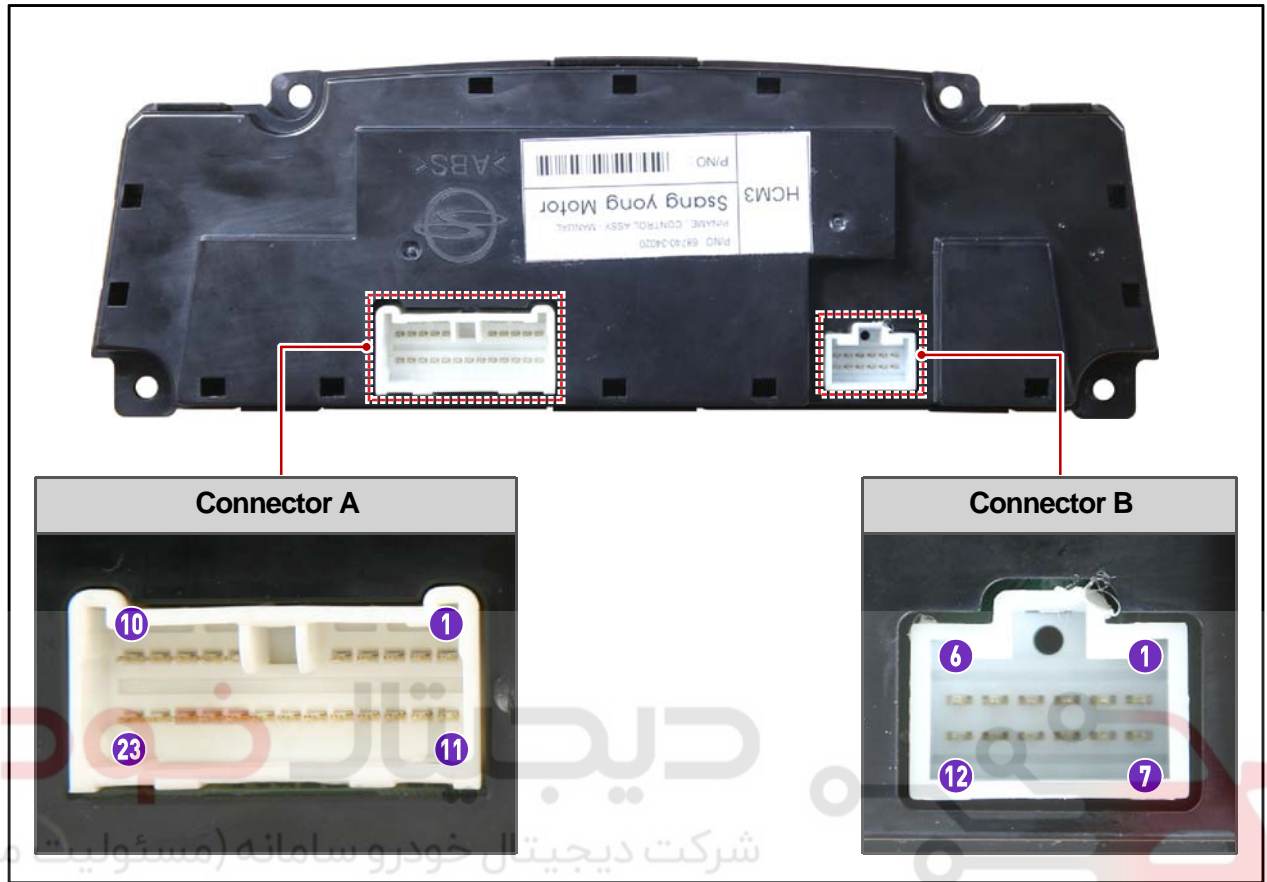

► Connector A

Pin No.	Function
1	Intake actuator (P2)
2	Mode actuator (P2)
3	Temp actuator (P2)
4	Temp actuator (P1)
5	Mode actuator (P1)
6	Vehicle speed signal
7	Actuator power
8	PTC signal
9	IGN +
10	B+
11	Intake actuator (P1)
12	Compressor operation signal

Pin No.	Function
13	Intake sensor signal
14	Blower feedback signal
15	Blower motor control signal
16	Sensor ground
17	Ground
18	Mode actuator position
19	Temp actuator position
20	Intake actuator position
21	Blower operation signal
22	MTC illumination +
23	MTC illumination -

Modification basis	
Application basis	
Affected VIN	

► Connector B

Pin No.	Function
1	-
2	-
3	-
4	-
5	Blower motor maximum operating signal
6	-
7	-
8	-
9	-
10	-
11	Ambient temperature sensor signal
12	-



شرکت دیجیتال خودرو سامانه (مسئولیت محدود)

اولین سامانه دیجیتال تعمیرکاران خودرو در ایران

Modification basis	
Application basis	
Affected VIN	

S.G.N.

6810-10 AIR CONDITIONER MODULE

1) Overview

The air conditioner module is mounted to inside of the instrument panel and has the evaporator core, heater core, PTC heater and corresponding actuator and different sensors.

2) Mounting Location & Components

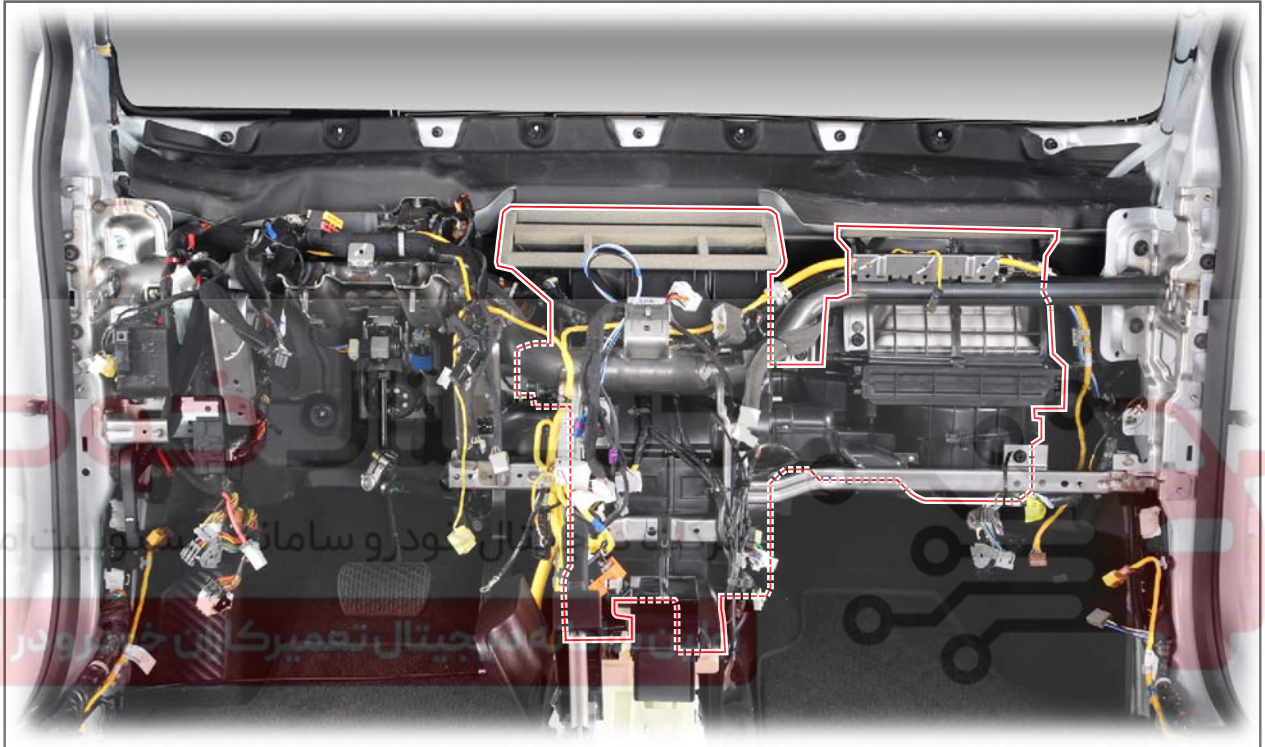

- AIR CONDITIONING
- AIR BAG
- SEAT
- SUNROOF
- BODY INTERIOR
- BODY EXTERIOR
- BODY REPAIR

Modification basis	
Application basis	
Affected VIN	

Air conditioner module

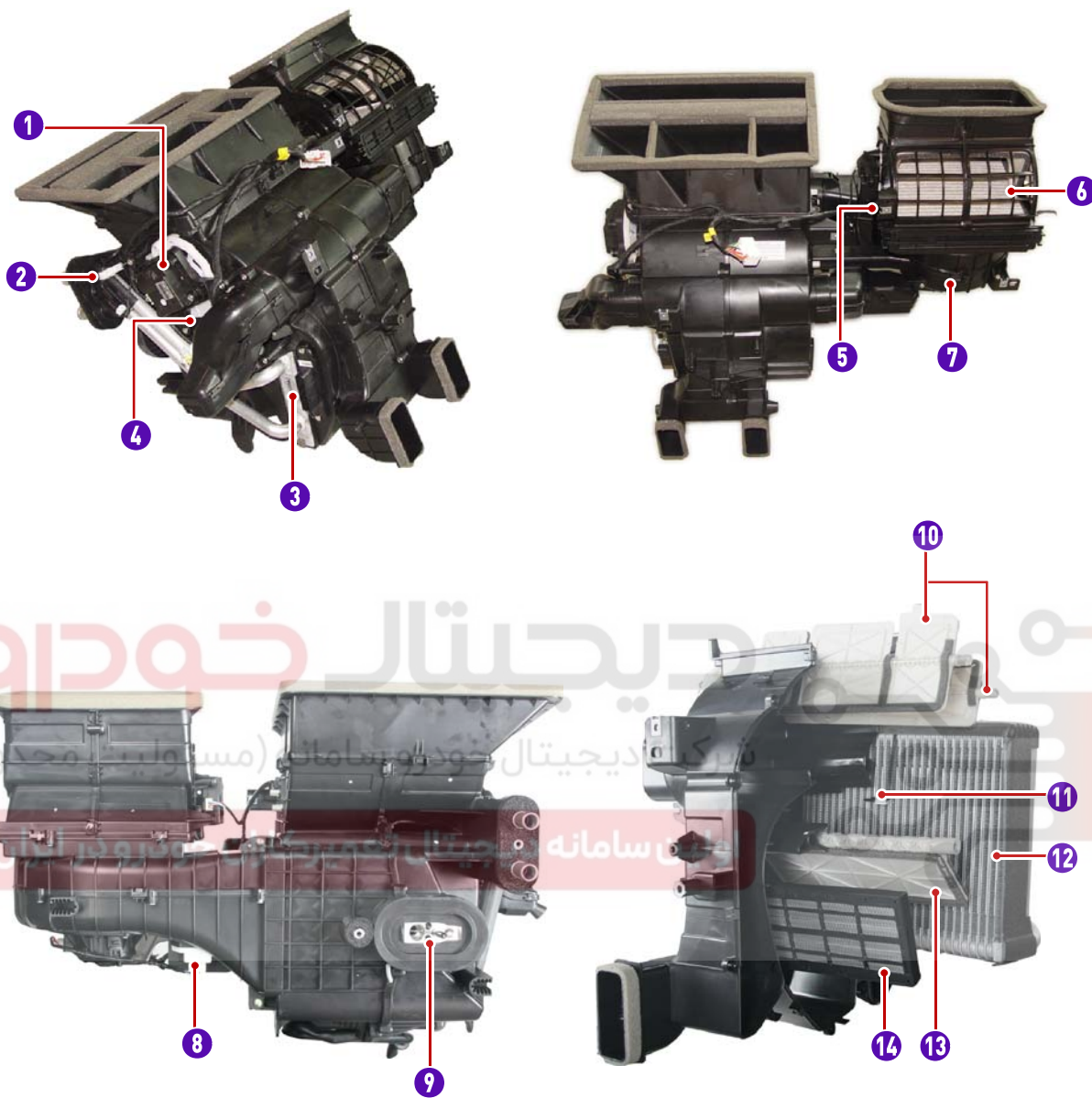

- 1. Mode actuator
- 2. Water temperature sensor
- 3. Heater core
- 4. Temp actuator
- 5. Intake actuator
- 6. A/C filter
- 7. Blower motor

- 8. MOS module
- 9. Expansion valve
- 10. Mode door
- 11. Intake sensor
- 12. Evaporator core
- 13. Temp door
- 14. PTC heater

Modification basis	
Application basis	
Affected VIN	

S.G.N.

6810-12 MODE ACTUATOR

1) Overview

The mode actuator is mounted on the top of the LH temp actuator of the heater and evaporator assembly. It controls the vent damper according to the control command from the heater and A/C control assembly to control the air distribution mode such as vent, bi-level, foot, defroster/foot or defroster.

2) Mounting Location & Components

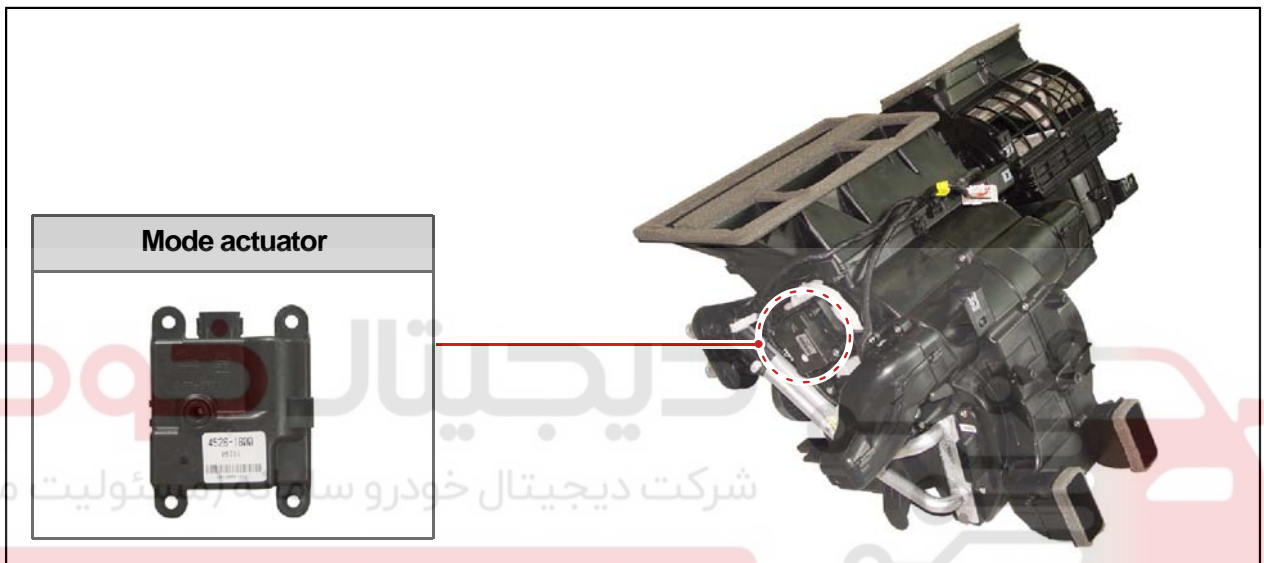

► Mode actuator operation position

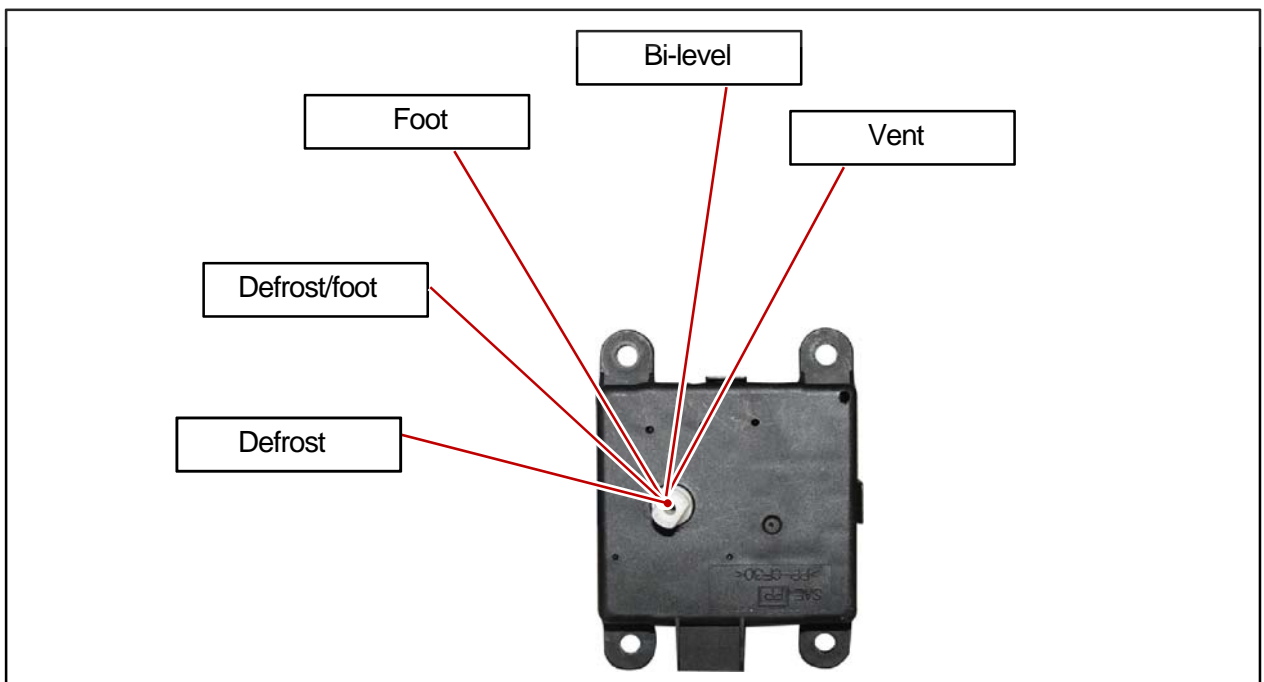

Modification basis	
Application basis	
Affected VIN	

3) Mode Actuator Connector



Pin No.	Function
1	-
2	Power +
3	Control
4	Sensor ground -
5	P2 (defroster)
6	P1 (vent)

Modification basis	
Application basis	
Affected VIN	

4) Circuit Diagram

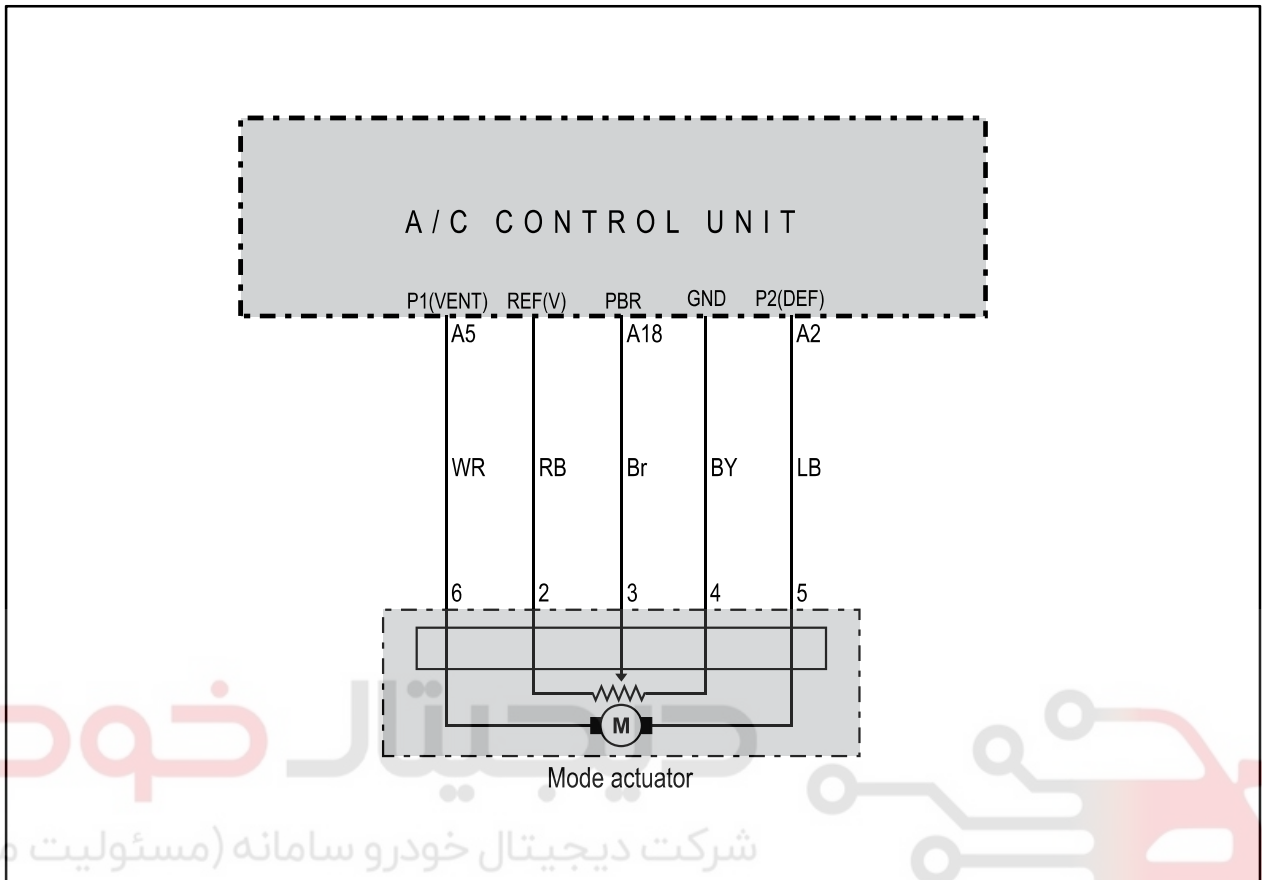

NOTE

How to check

- Turn the ignition switch to the "ON" position. Then, check the operation position of the actuators by modes while changing the mode.
- If the operating position is not correct, check the wiring for open circuit.
- If the wiring is intact, replace the mode actuator assembly.

Modification basis	
Application basis	
Affected VIN	

S.G.N. **6810-02 INTAKE ACTUATOR**

1) Overview

The intake actuator is mounted to the left-hand of the blower assembly and changes the air source selection mode according to the control command from the heater and A/C control assembly.

2) Mounting Location & Components



► Intake actuator operation position

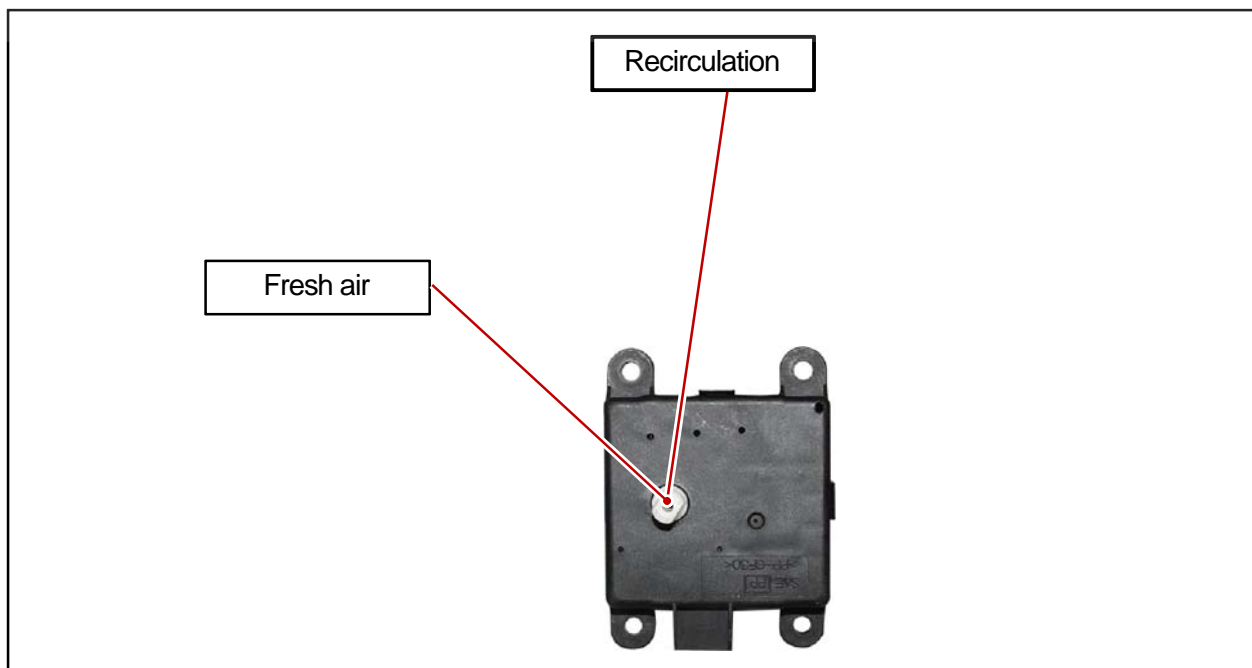

Modification basis	
Application basis	
Affected VIN	

3) Connector

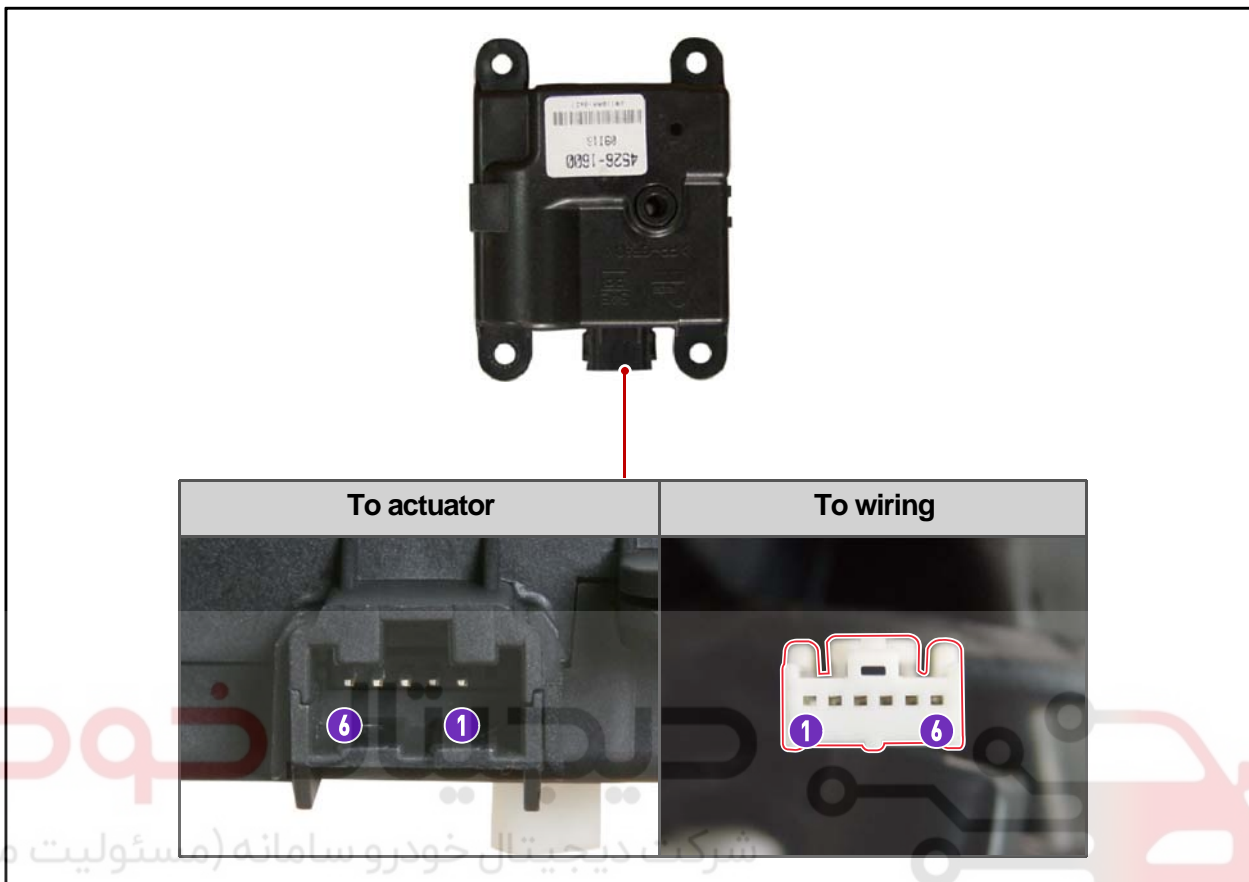

Pin No.	Function
1	-
2	Power +
3	Control
4	Sensor ground -
5	P2 (recirculation)
6	P1 (fresh air)

AIR CONDITIONING
AIR BAG
SEAT
SUNROOF
BODY INTERIOR
BODY EXTERIOR
BODY REPAIR

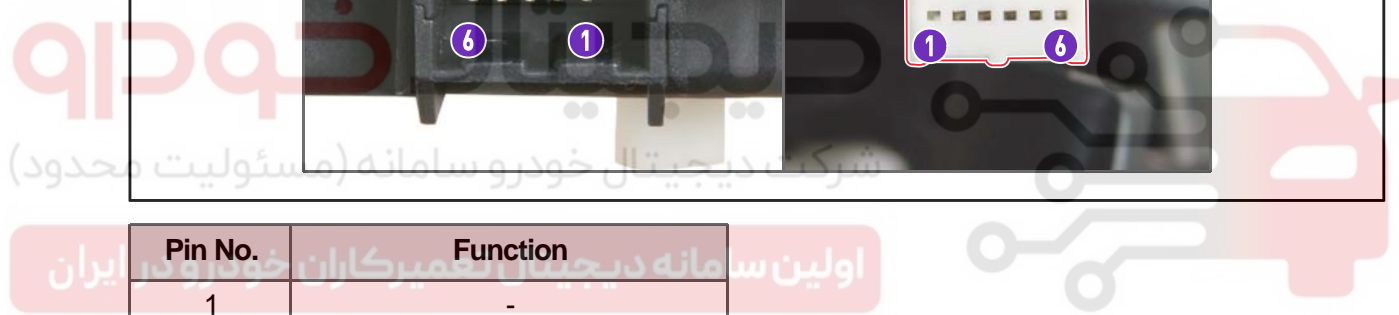

Modification basis	
Application basis	
Affected VIN	

4) Circuit Diagram

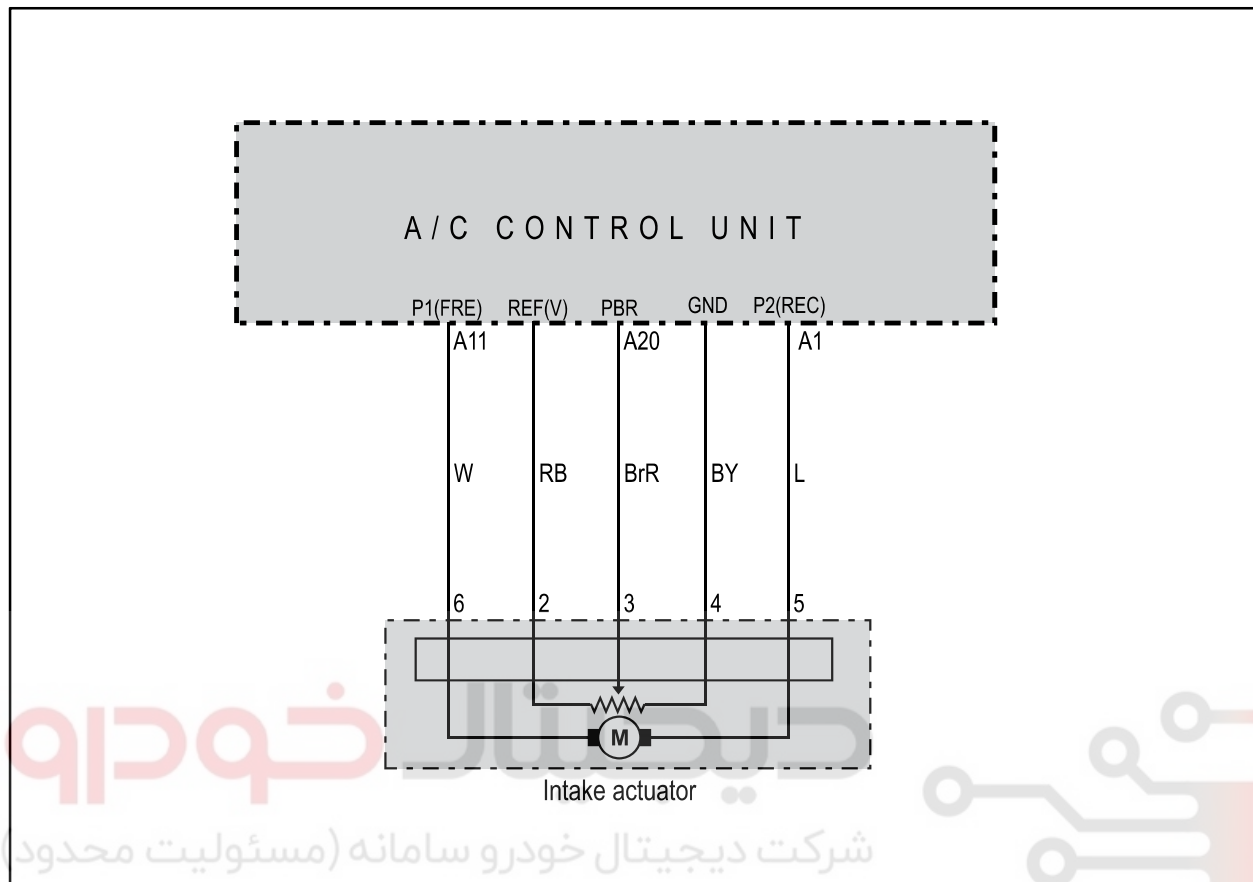

NOTE

How to check

- Turn the ignition switch to the "ON" position. Then, check the operation position of the actuator each time the mode is changed.
- If the operating position is not correct, check the wiring for open circuit.
- If the wiring is intact, replace the intake actuator.

Modification basis	
Application basis	
Affected VIN	

S.G.N.
6810-11 TEMP ACTUATOR

1) Overview

The temp actuator is mounted on the bottom of the LH mode actuator of the heater and evaporator assembly. It changes the motor position according to the control command from the heater and A/C control assembly to adjust the outlet air temperature.

2) Mounting Location & Components

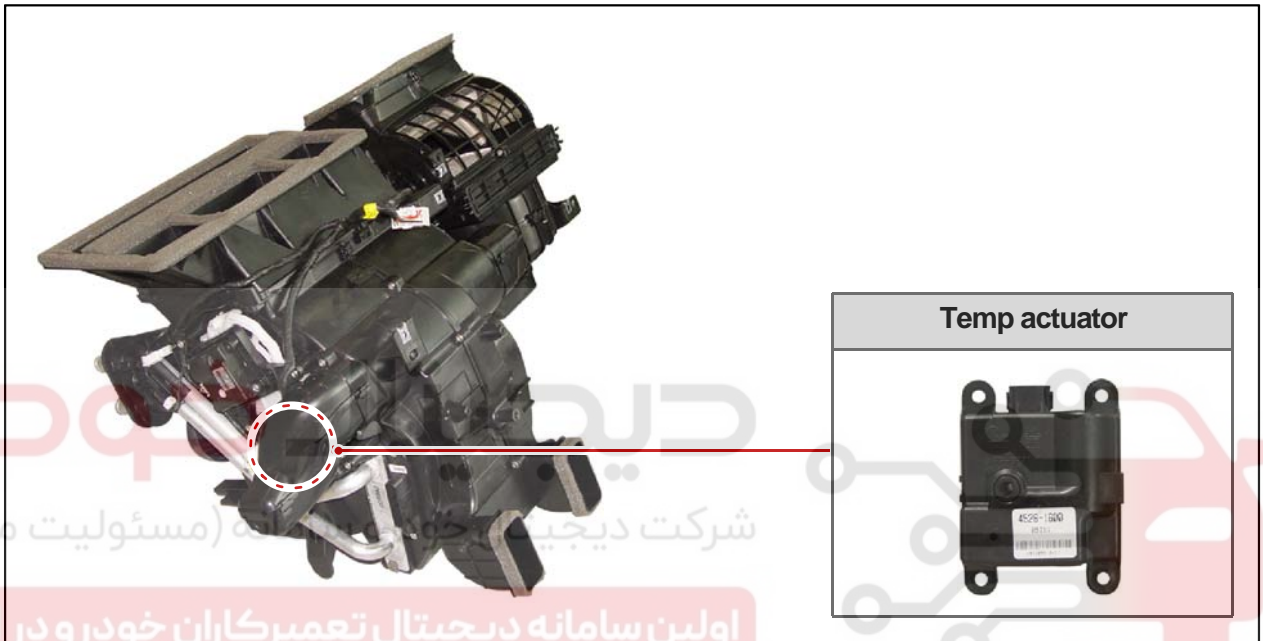

► Operating range

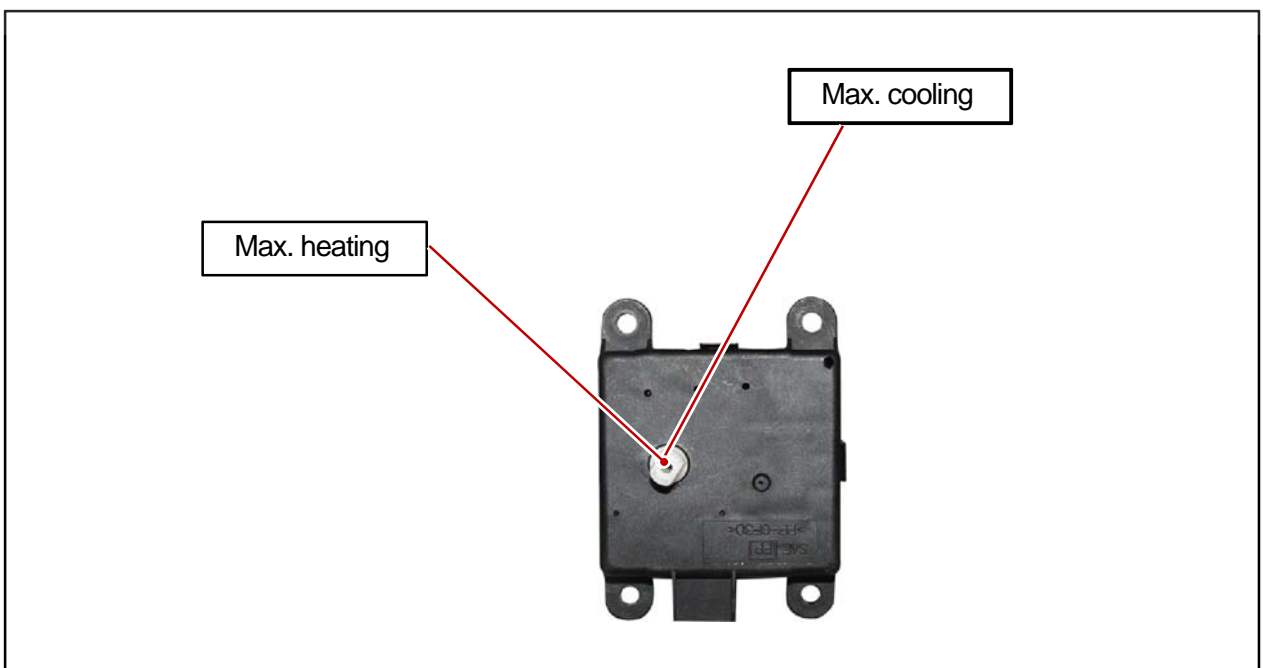

Modification basis	
Application basis	
Affected VIN	

3) Temp Actuator Connector

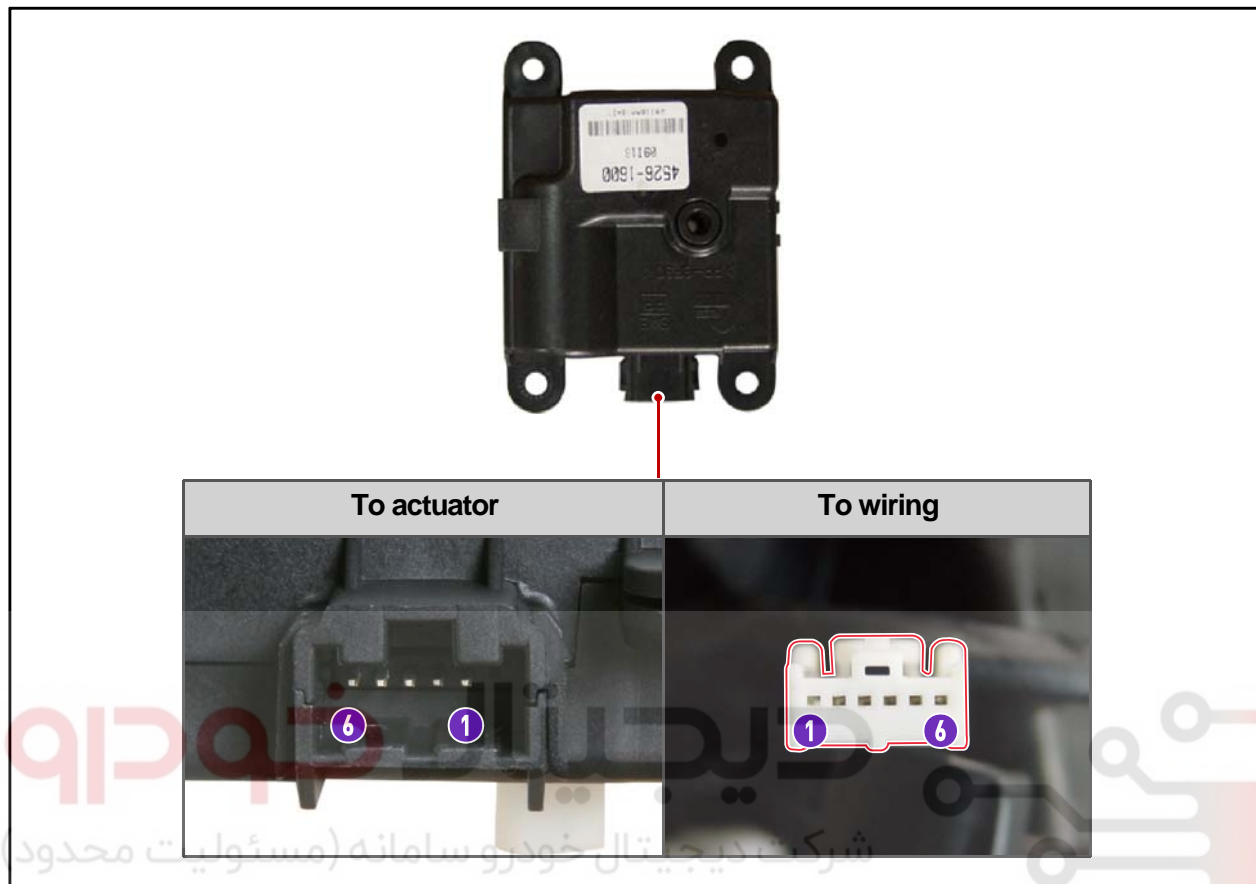

Pin No.	Function
1	-
2	Power +
3	Control
4	Sensor ground -
5	P2 (cool air)
6	P1 (warm air)

Modification basis	
Application basis	
Affected VIN	

4) Circuit Diagram

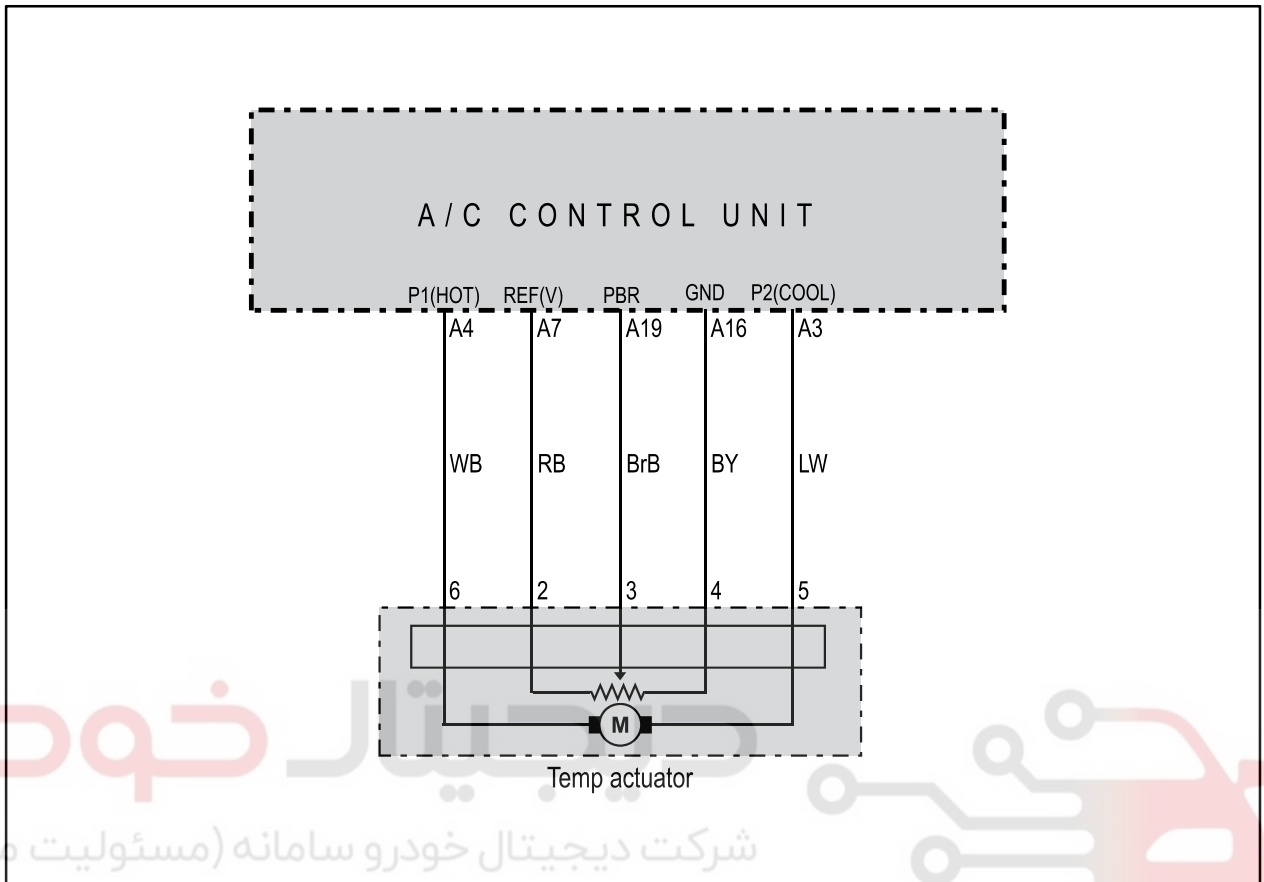

NOTE

How to check

- a. Turn the ignition switch to the "ON" position. Then, check the operation position of the actuator while changing the set temperature of the air conditioning system.
- b. If the operating position is not correct, check the wiring for open circuit.
- c. If the wiring is intact, replace the temp actuator.

Modification basis	
Application basis	
Affected VIN	

S.G.N. 6810-23 INCAR SENSOR

1) Overview

The incar sensor is a negative temperature coefficient (NTC) thermistor, and mounted to the rear of the heater and A/C control assembly (with FATC). It detects the air temperature drawn through the indoor temperature sensing part at front section of the heater and A/C control assembly and sends the voltage value according to the changed resistance to the FATC.

2) Mounting Location & Components



Modification basis	
Application basis	
Affected VIN	

3) Incar Sensor Connector

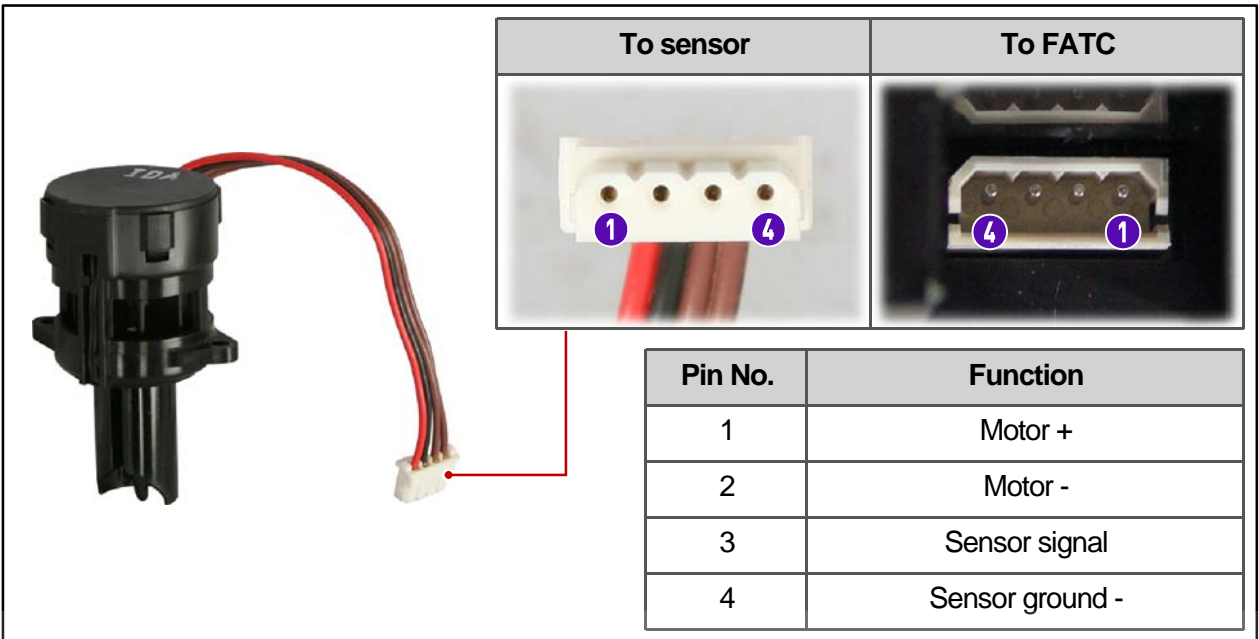

Pin No.	Function
1	Motor +
2	Motor -
3	Sensor signal
4	Sensor ground -

4) Circuit Diagram

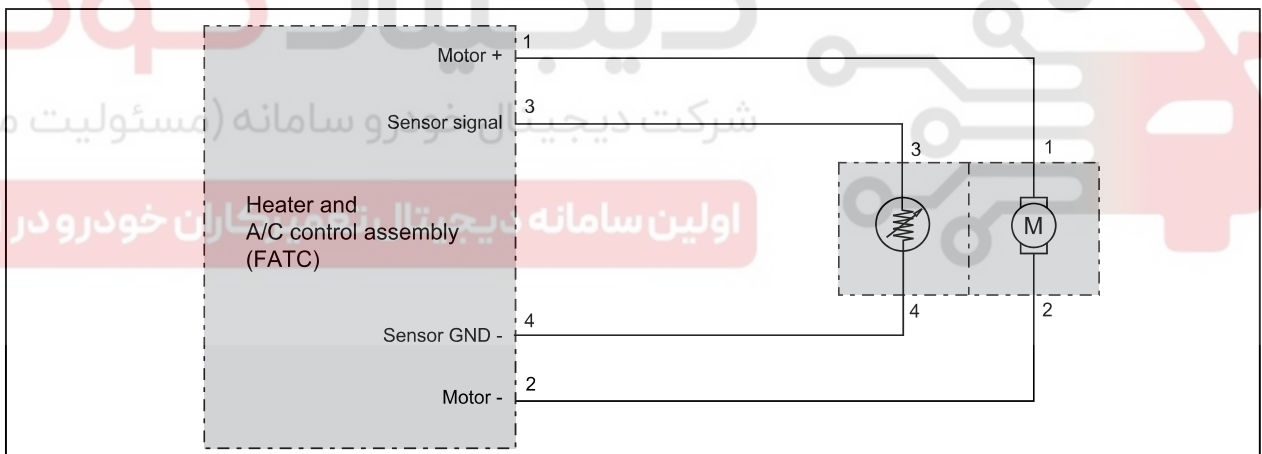

NOTE

How to check

- Remove the incar sensor and measure the resistances at both ends of the sensor connector. If the measured resistance is extremely high or low, replace the incar sensor. (specified value: $2.186 \text{ k}\Omega \pm 3\%$ at 25°C)
- If the resistance value of the sensor is normal, check the following:
 - Turn the ignition switch to ON position and measure the voltage between the terminals No. 3 and No. 4 of the incar sensor connector (to FATC). (measured voltage: approx. 1.7 V at 2) If the voltage cannot be measured, check the wiring for open circuit. If the result is as specified,
 - replace the heater and A/C control assembly.

Modification basis	
Application basis	
Affected VIN	

S.G.N. **6810-00 WATER TEMPERATURE SENSOR**

1) Overview

This sensor is a negative temperature coefficient (NTC) thermistor, and mounted to the left heater pipe cover of the heater and evaporator assembly. It detects the coolant temperature to send the voltage value according to the resistance change to the heater and A/C control assembly (with FATC).

2) Mounting Location & Components

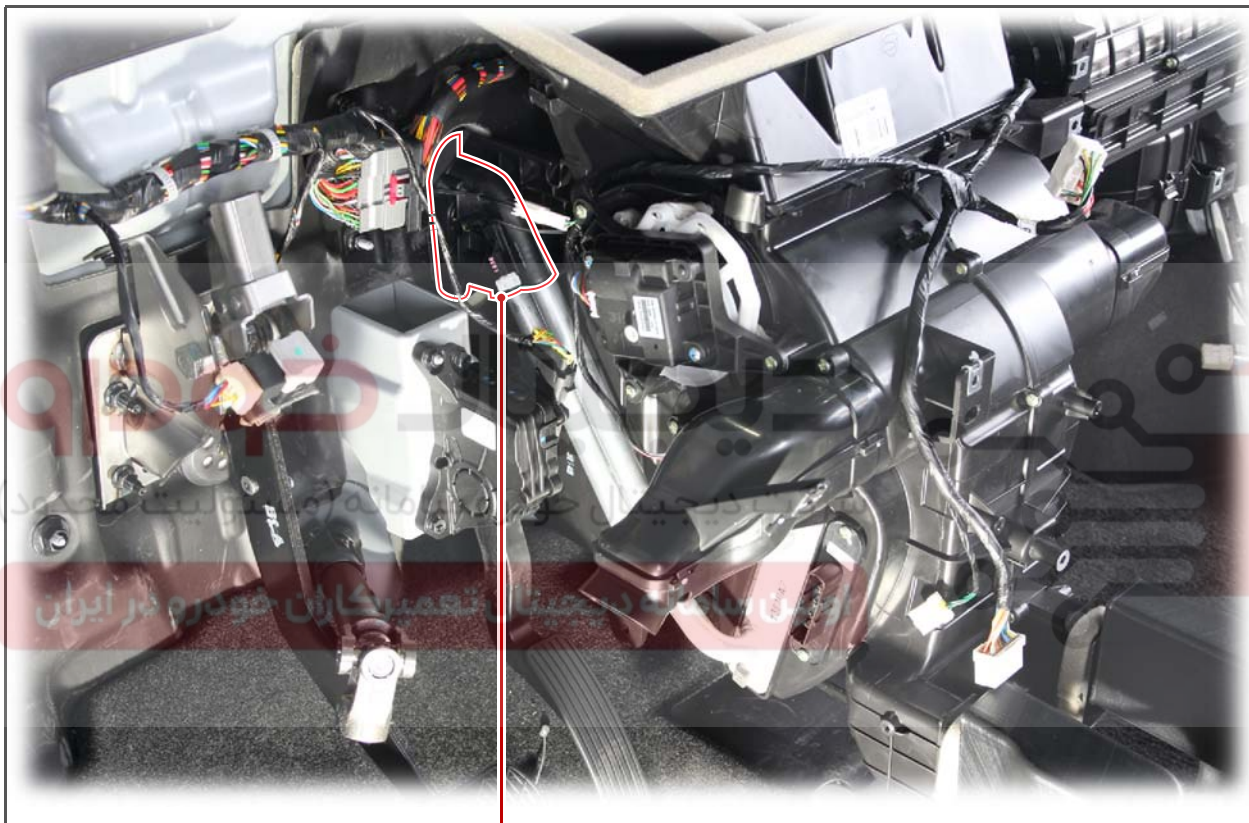

Water temperature sensor	
Mounted view	Component
	<p>Heater pipe cover</p>

Modification basis	
Application basis	
Affected VIN	

3) Water Temperature Sensor Connector

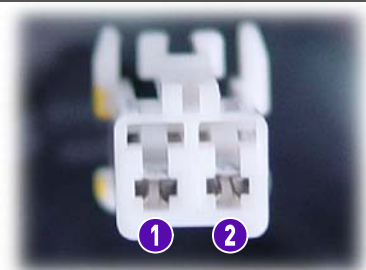
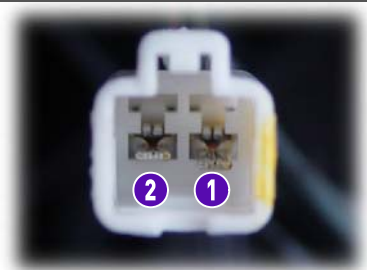

To sensor	To wiring
	

Pin No.	Function
1	Sensor ground -
2	Sensor signal

4) Circuit Diagram

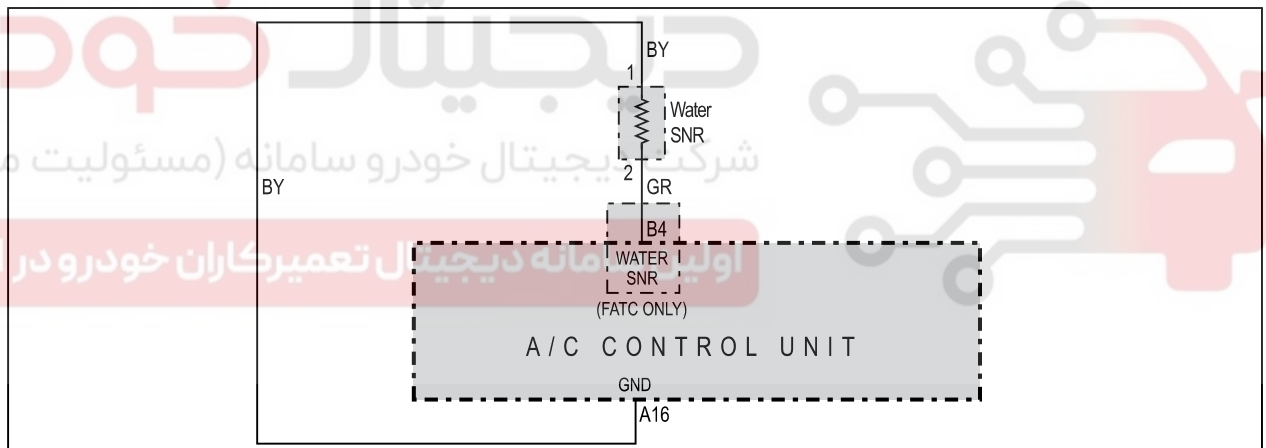

NOTE

How to check

- Remove the water temperature sensor and measure the resistances at both ends of the sensor connector. If the measured resistance is extremely high or low, replace the water temperature sensor. (Specification: $2.186 \text{ k}\Omega \pm 3\%$ at 25°C)
- If the measured value is out of the specified range, replace the water temperature sensor. If the measured value is within the specified range, check as described below:
 - Turn the ignition switch to the "ON" position and measure the voltage between the B connector terminal No. 4 and the A connector terminal No. 16 of the FATC. (specified voltage: approx. 1.1 V at 25°C)
 - If the voltage cannot be measured, check the wiring for open circuit. If the result is as specified, replace the heater and A/C control assembly.

Modification basis	
Application basis	
Affected VIN	

S.G.N. **6810-24 INTAKE SENSOR**

1) Overview

The intake sensor is a negative temperature coefficient (NTC) thermistor, and mounted to the side of the evaporator core in the heater and evaporator assembly. This is used to detect the temperature of the evaporator core to output the voltage value to the heater and A/C control assembly depending on the resistance changes and prevent the evaporator core from being freezing.

2) Mounting Location & Components

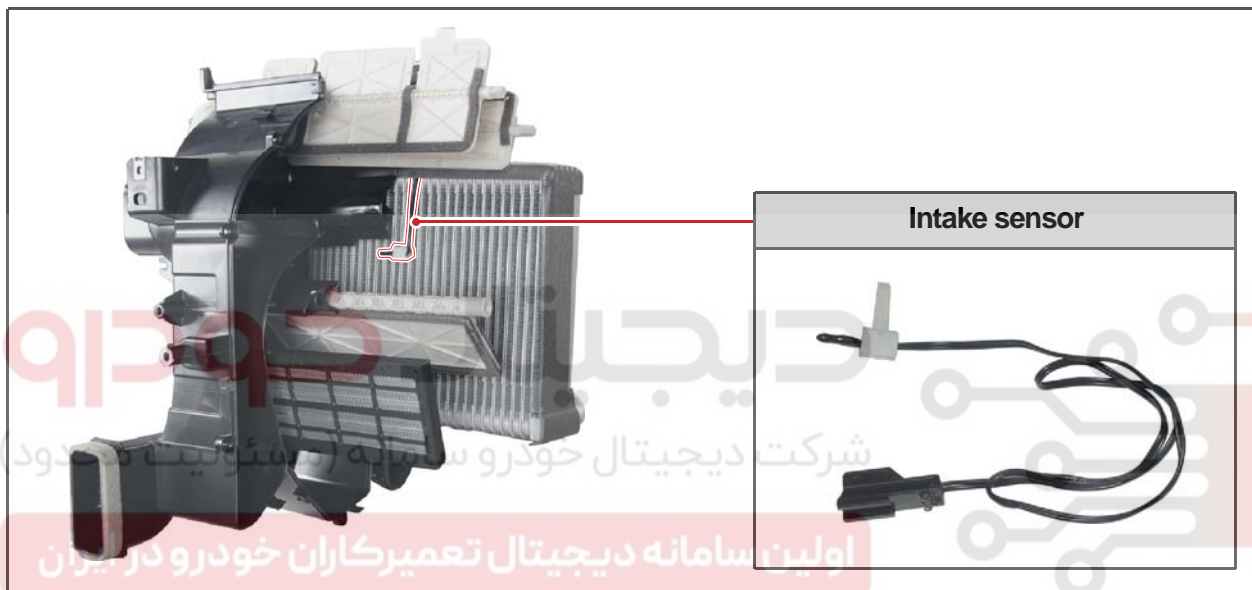

3) Connector

The diagram shows the connector with two pins labeled 1 and 2. A red line points from the connector to a detailed view of the connector's internal structure. The detailed view shows two pins labeled 1 and 2. A table below the diagram defines the functions of the pins.

Pin No.	Function
1	Sensor ground -
2	Signal

4) Circuit Diagram

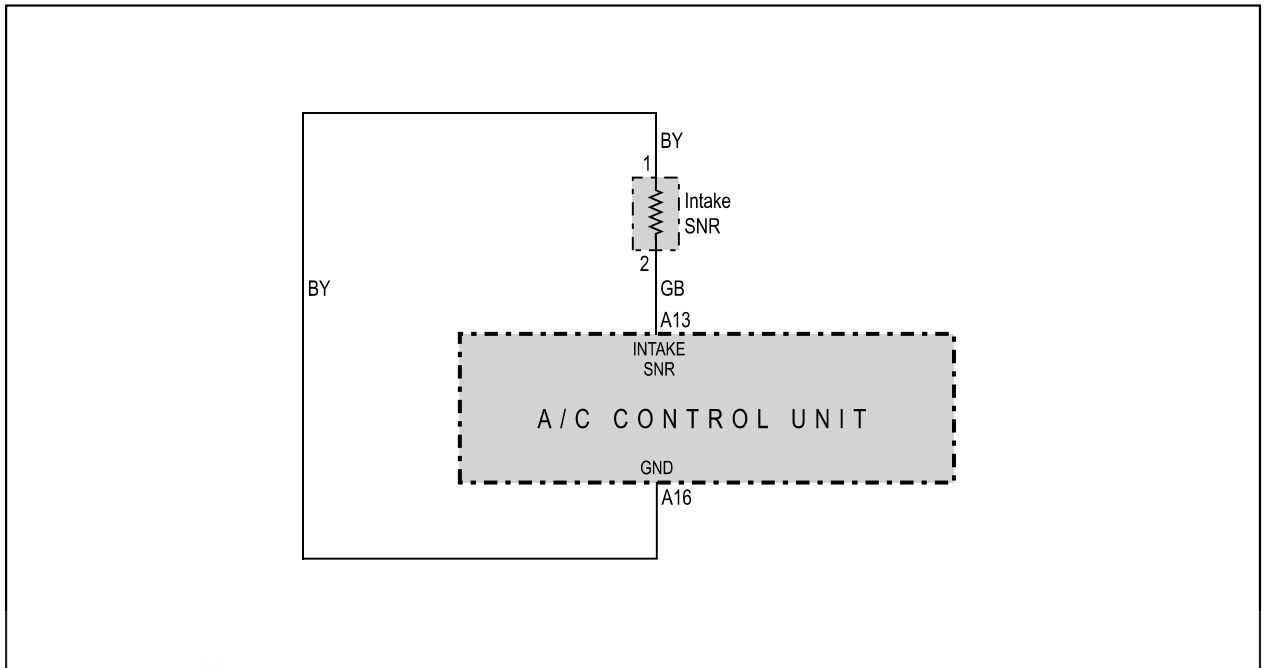

NOTE

How to check

- a. Remove the intake sensor and measure the resistances at both ends of the sensor connector. If the measured resistance is extremely high or low, replace the intake sensor. (Specification: $\pm 1\%$ at 1°C)
- b. If the measured value is out of the specified range, replace the intake sensor. If the measured value is within the specified range, check as described below:
 - Turn the ignition switch to the "ON" position and measure the voltage between the A connector terminal No. 13 and the A connector terminal No. 16 of the FATC. (Specification: approx. 5.1 V at 1°C)
 - If the voltage cannot be measured, check the wiring for open circuit. If the result is as specified, replace the heater and A/C control assembly.

Modification basis	
Application basis	
Affected VIN	

S.G.N. **6810-06** MOS MODULE

1) Overview

The MOS module is mounted at the bottom of the blower assembly and controls the fan speed. It receives the fan speed control signal from the heater and A/C control assembly to control the rotation speed of the blower motor by adjusting the current applied to the base of the MOS module.

2) Mounting Location & Components



Modification basis	
Application basis	
Affected VIN	

3) MOS Module Connector

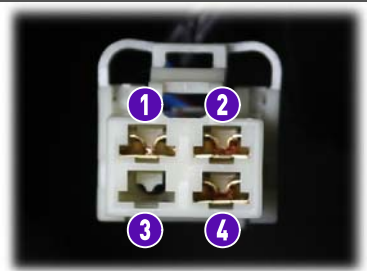

To module	To wiring
	

Pin No.	Function
1	Fan speed control
2	Blower F/B
3	-
4	Ground -

4) Circuit Diagram

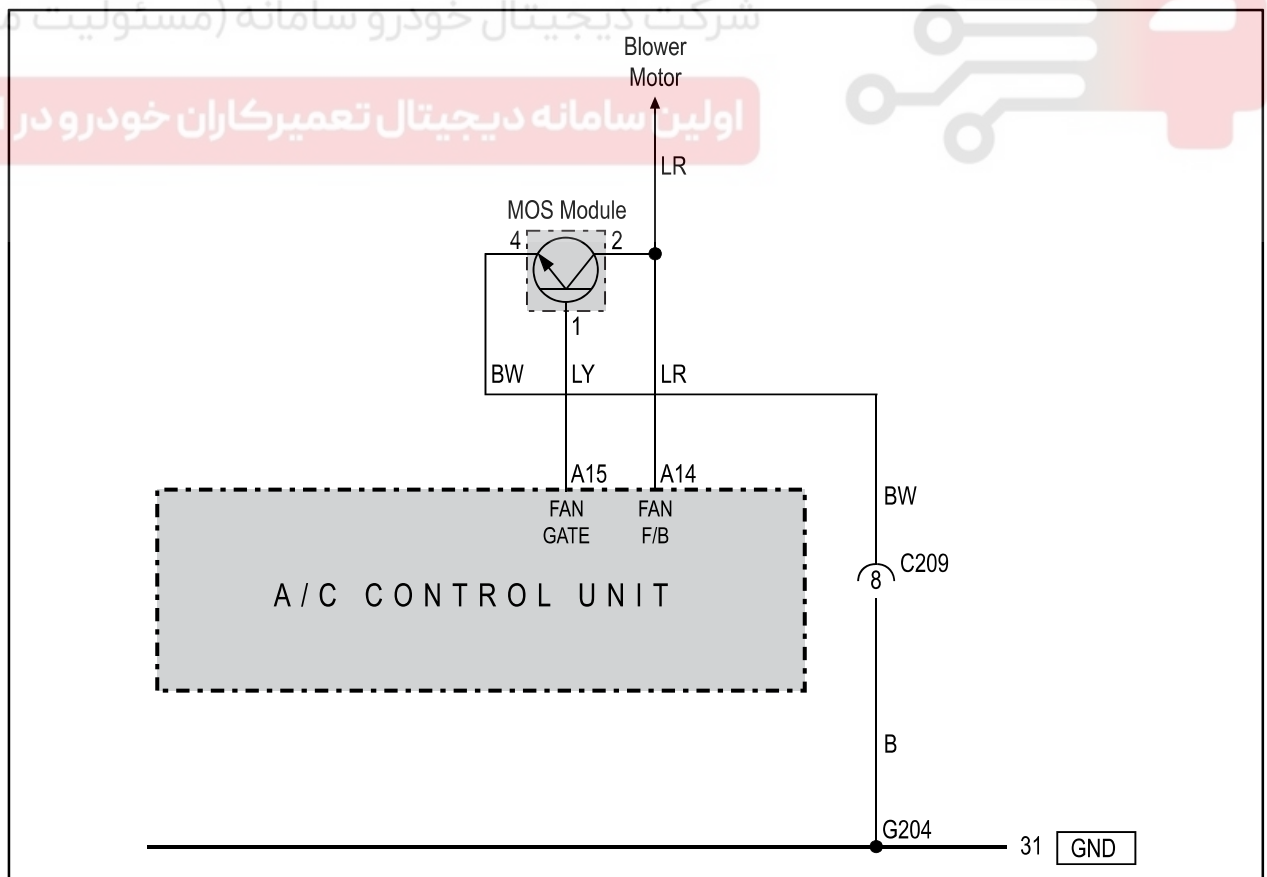

Modification basis	
Application basis	
Affected VIN	

S.G.N. **6810-05 BLOWER MOTOR**

1) Overview

It is mounted at the bottom of the blower assembly and sends the staged air inside of the vehicle by the MOS module control.

2) Mounting Location & Components

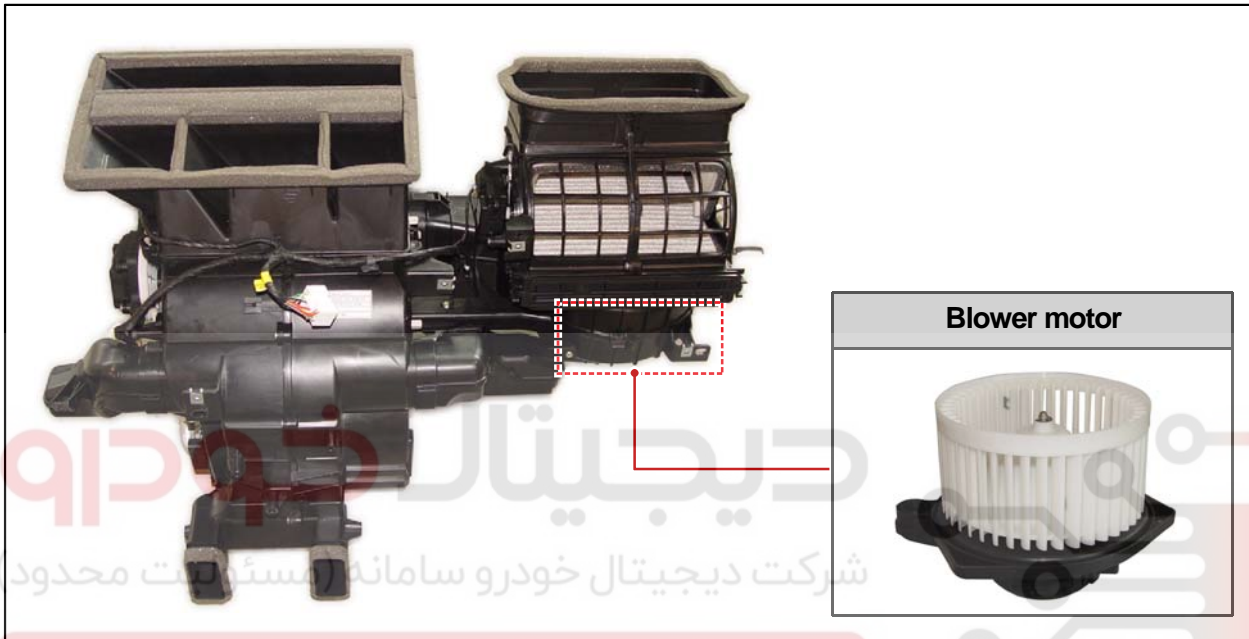

اولین سامانه دیجیتال خودرو در ایران

3) Blower Motor Connector

The diagram shows the blower motor with a connector. Two pins are labeled 1 and 2. The connector is shown from two perspectives: 'To motor' and 'To wiring'.

Pin No.	Function
1	B+
2	Blower F/B

Modification basis	
Application basis	
Affected VIN	

4) Circuit Diagram

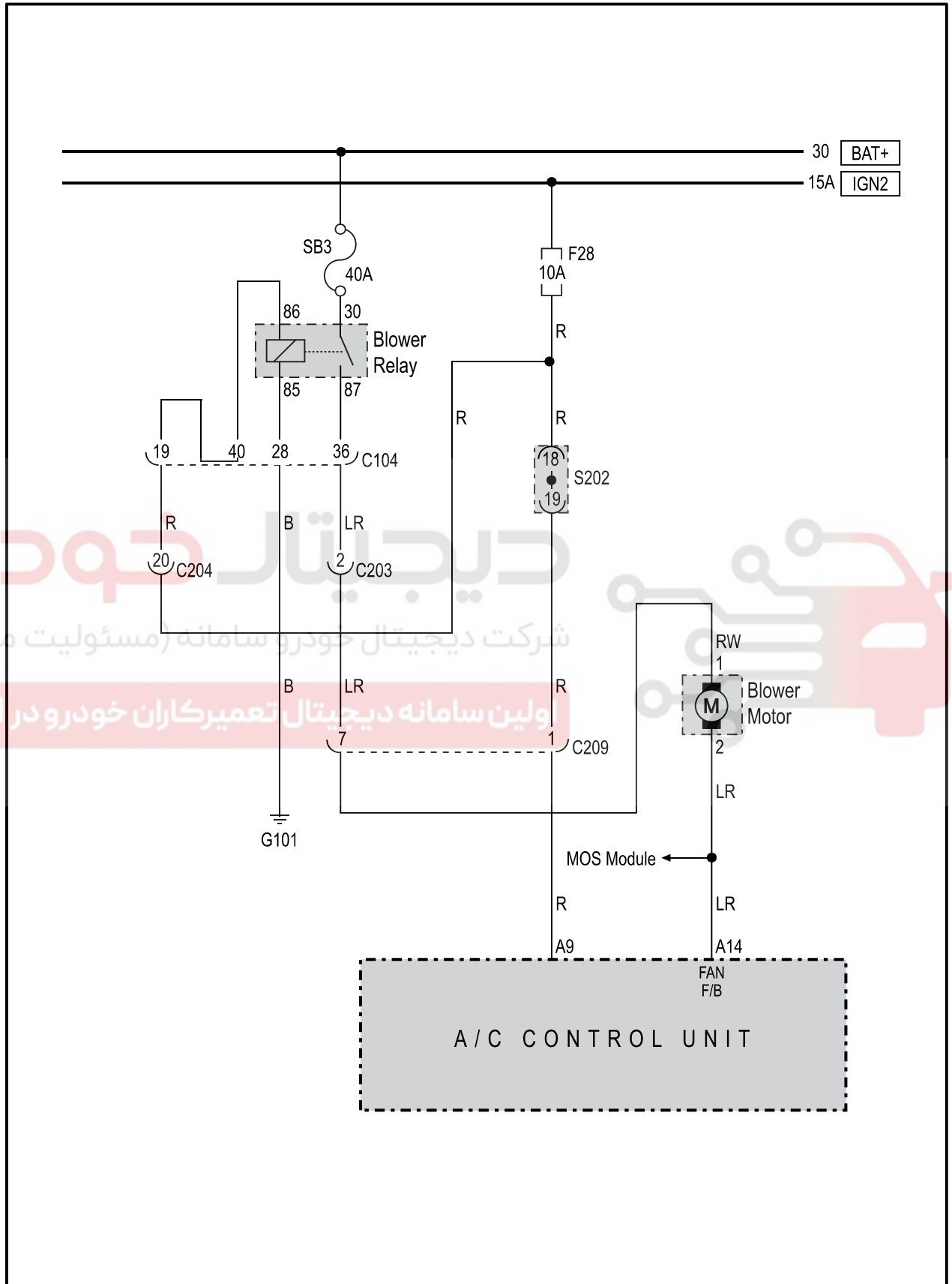

- AIR CONDITIONING
- AIR BAG
- SEAT
- SUNROOF
- BODY INTERIOR
- BODY EXTERIOR
- BODY REPAIR

دیجیتال خودرو
 شرکت دیجیتال خودرو سامانه (مسئولیت محدود)
 اولین سامانه دیجیتال تعمیرکاران خودرو در ایران

Modification basis	
Application basis	
Affected VIN	

S.G.N. 6810-03 A/C FILTER

1) Overview

The A/C filter is mounted on the top of the blower motor so that air passes through the filter before it is discharged through the duct. The A/C filter is in one-piece to reduce the resistance of the coming and going air and optimize the filtering effect.



NOTE

Change interval

- Replace at every 10,000 km of driving.
- If the vehicle is driven under severe conditions such as dusty road, unpaved road, and excessive A/C and heater operation, shorten the replacement interval.

2) Mounting Location and Components

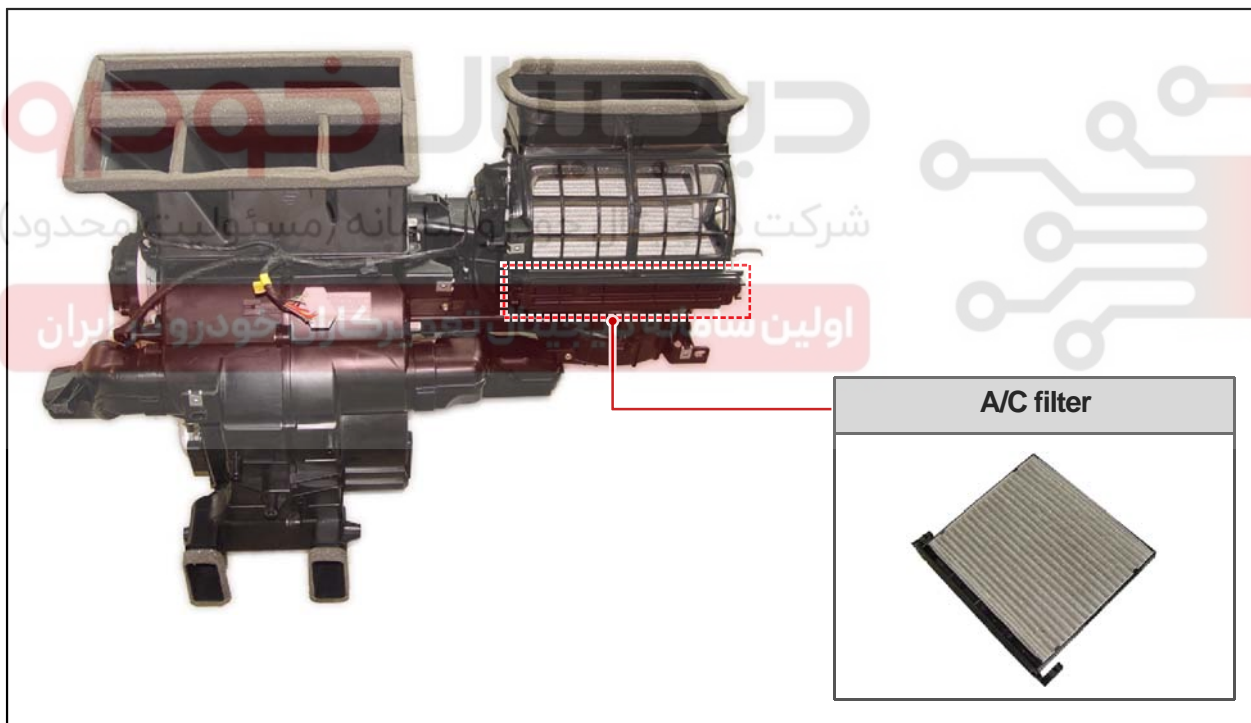

NOTE

How to check

- Remove the A/C air filter to check the filter for contamination and clogging by foreign materials. Replace the filter as necessary even within the replacement interval.

Modification basis	
Application basis	
Affected VIN	

S.G.N.

8520-18 SUN LOAD SENSOR

1) Overview

The sun load sensor is mounted to the left-hand of the driver's instrument panel. The photo diode, which converts the changes in light intensity into the electrical changes, detects the amount of light coming through windshield and changes it into the current and then sends the signal to the heater and A/C control assembly (with FATC).



NOTE

Photo diode

It uses the characteristic that the current is changed according to the amount of light on the photosensitive surface.

2) Mounting Location & Components



AIR
CONDITIO

AIR BAG

SEAT

SUNROO
F

BODY
INTERIOR

BODY
EXTERIO

BODY
REPAIR

Modification basis	
Application basis	
Affected VIN	

3) Connector

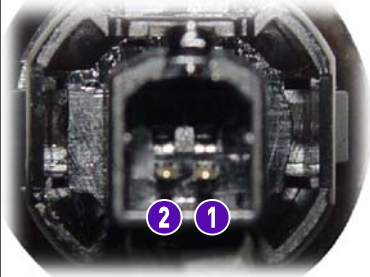
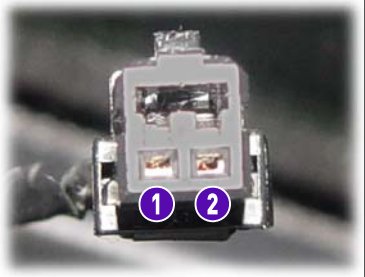

To sensor	To wiring
	

Pin No.	Function
1	Sensor ground -
2	Sensor signal

4) Circuit Diagram

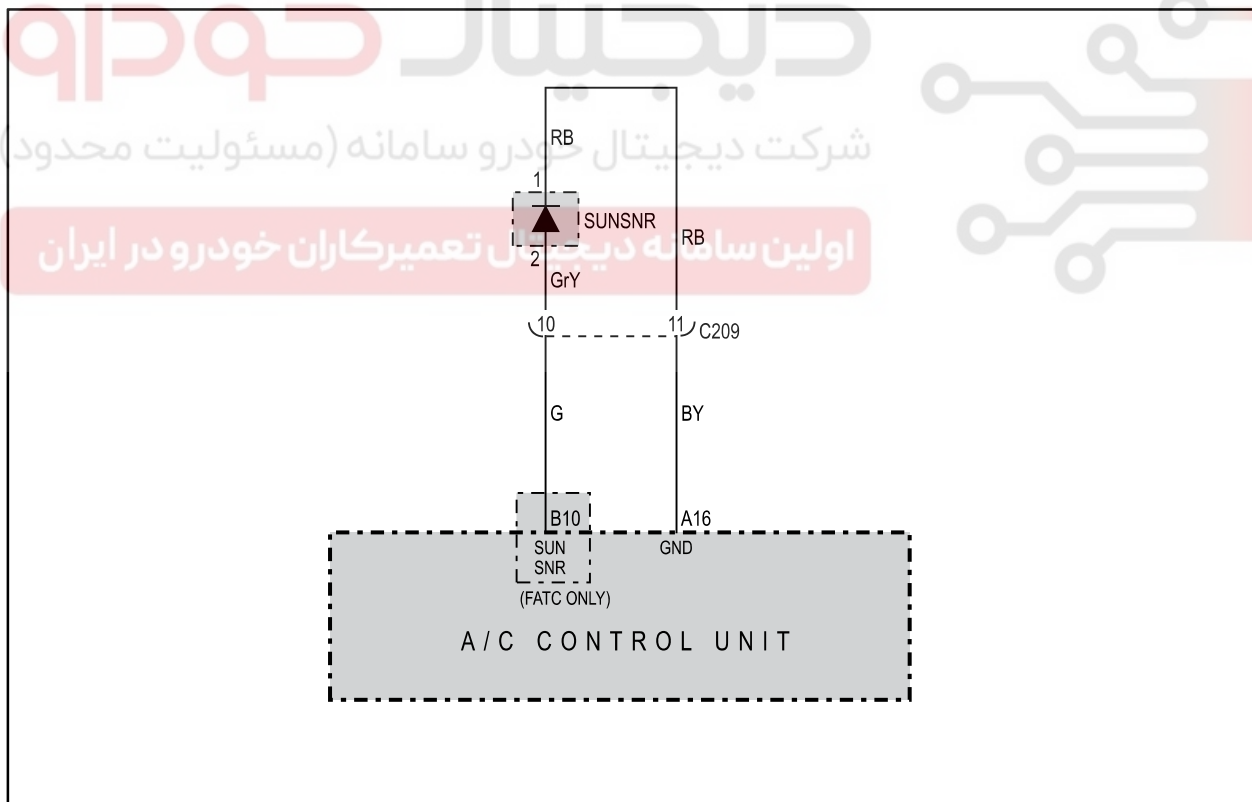

Modification basis	
Application basis	
Affected VIN	

**NOTE****How to check**

- a. Remove the sun-load sensor and measure the current between the terminals with the sensor exposed to direct sunlight.
- b. Measure the current again under shade. It is normal if the measured value is less than the measured value in direct sunlight. Check the followings:
 - Turn the ignition switch to the "ON" position and measure the voltage between the B connector terminal No. 10 and the A connector terminal No. 16 of the FATC.
(Specified value: approx. 1.7 V in direct sunlight, approx. 3.1 V under shade)
 - If the voltage cannot be measured, check the wiring for open circuit. If the result is as specified, replace the heater and A/C control assembly.

دیجیتال خودرو

شرکت دیجیتال خودرو سامانه (مسئولیت محدود)

اولین سامانه دیجیتال تعمیرکاران خودرو در ایران



Modification basis	
Application basis	
Affected VIN	

8520-14 AMBIENT TEMPERATURE SENSOR

1) Overview

This sensor, which located to the front bumper inner rail, is a negative temperature coefficient (NTC) thermistor and detects the ambient temperature to send the voltage value according to the resistance change to the A/C control unit.

2) Mounting Location & Components

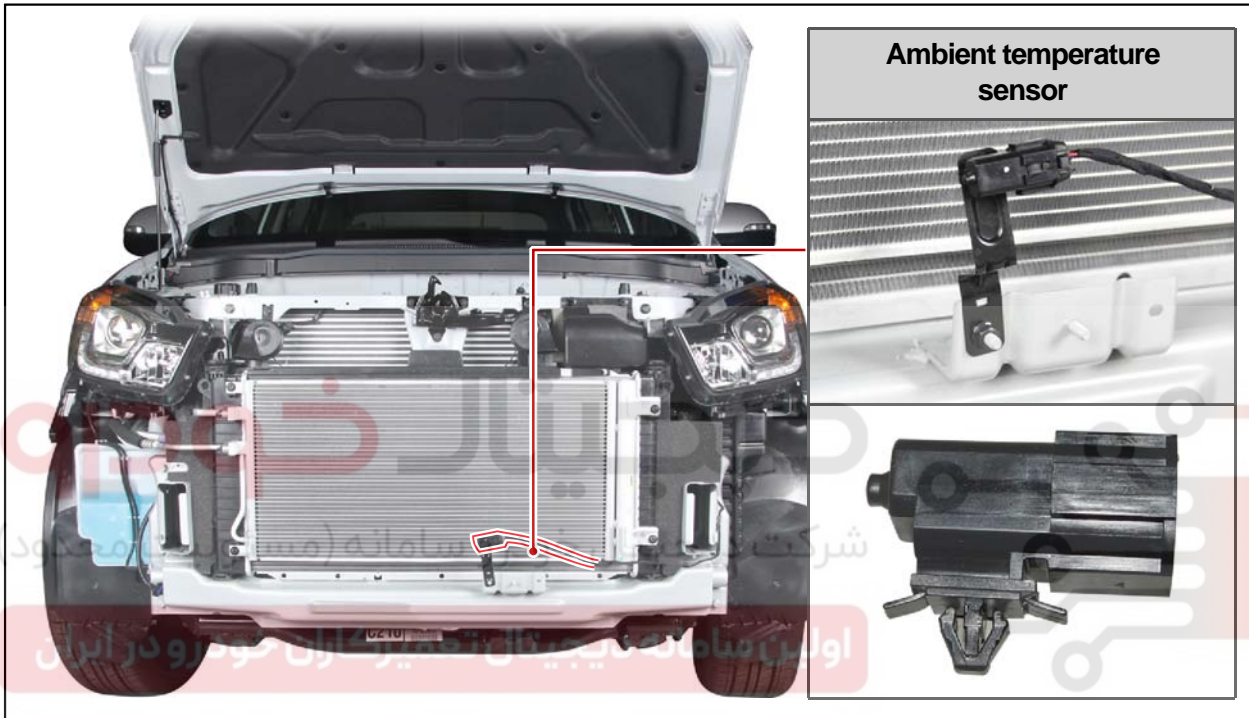

3) Ambient Temperature Sensor Connector

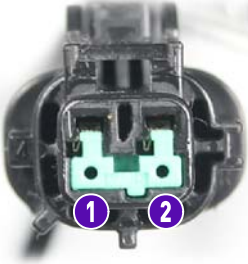
To sensor	To wiring
	

Pin No.	Function
1	Sensor ground (-)
2	Sensor signal

Modification basis	
Application basis	
Affected VIN	

4) Circuit Diagram

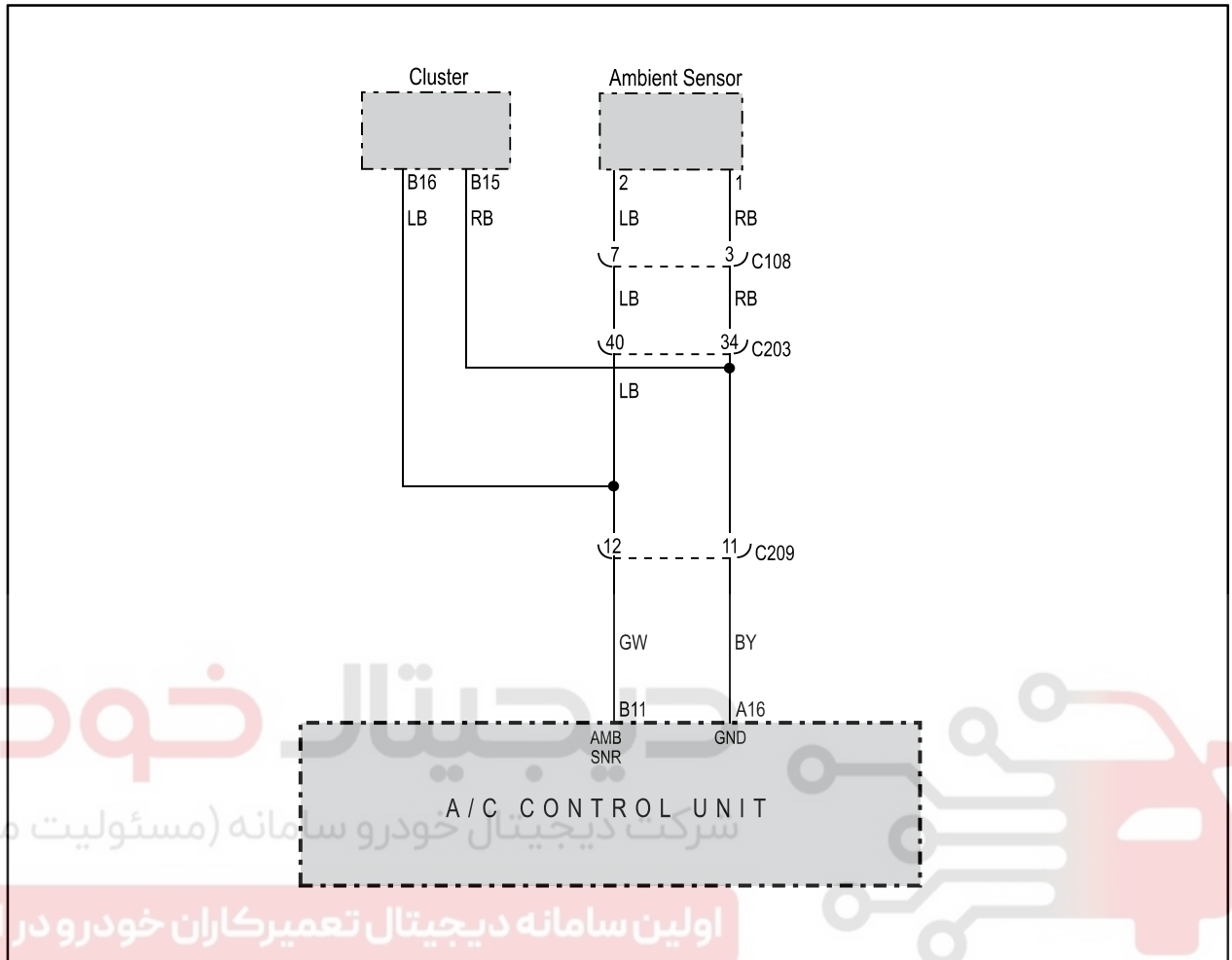

NOTE

How to check

- a. Remove the ambient temperature sensor and measure the resistances at both ends of the sensor connector. If the measured resistance is extremely high or low, replace the ambient temperature sensor. (specified value: 2.186 kΩ±3% at 25 °C)
- b. If the measured value is out of the specified range, replace the ambient temperature sensor. If the measured value is within the specified range, check as described below:
 - Turn the ignition switch to the "ON" position and measure the voltage between the connector B terminal No. 11 and connector A terminal No. 16 of the heater and A/C control assembly. (measured voltage: approx. 1.7 V at 25 °C)
 - If the voltage cannot be measured, check the wiring for open circuit. If the result is as specified, replace the heater and A/C control assembly.

Modification basis	
Application basis	
Affected VIN	

S.G.N.
8520-15 PTC HEATER

1) Overview

The PTC (Positive Temperature Coefficient) heater is mounted to the heater air outlet of the air conditioner module. This is used to assist the heating until the engine coolant temperature reaches to normal range when operating the heater with the vehicle cold. Since the PTC system is heated by the electrical power, the electric load and alternator capacity is greater than the conventional one. The PTC is not operated when a) the engine is cranking, b) the battery voltage is below 11 V, c) the glow plug is being preheated.

2) Mounting Location & Components

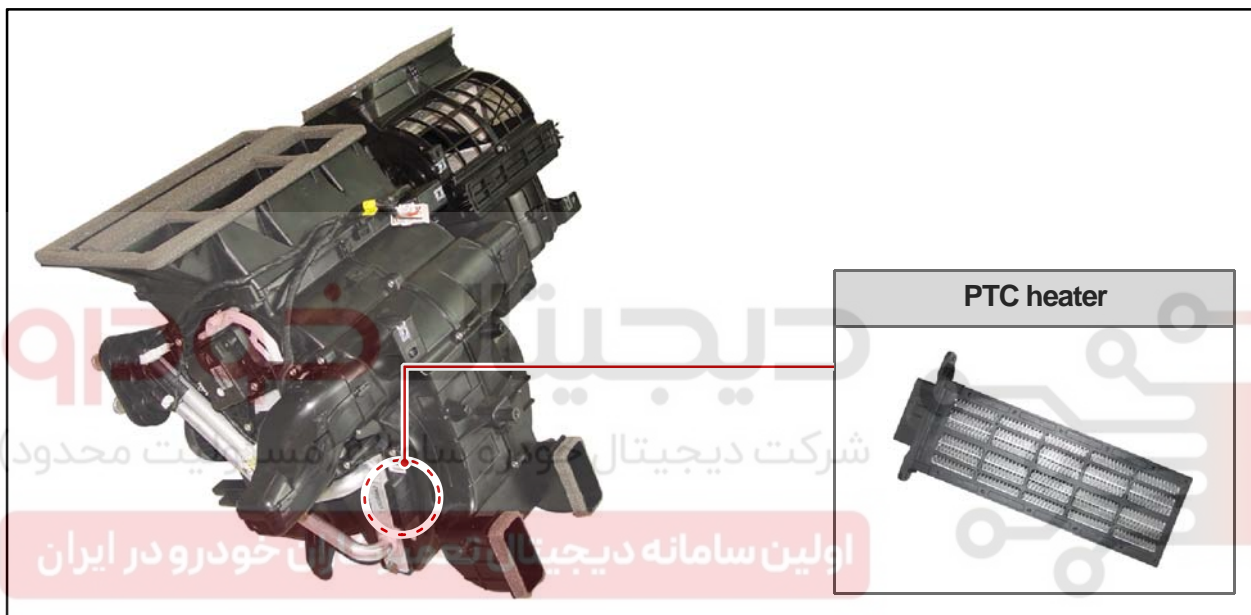

► Exploded view

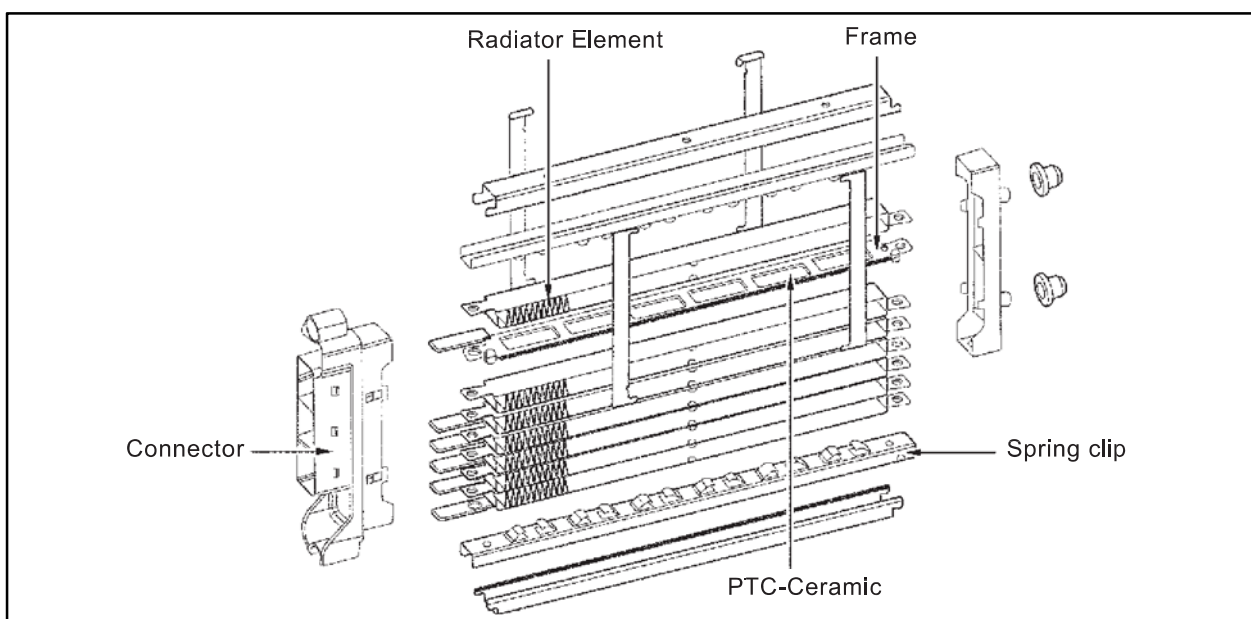

Modification basis	
Application basis	
Affected VIN	

3) PTC Heater Connector

Pin No.	Function
1	Heater 1
2	Ground -
3	Heater 2
4	Ground -
5	Heater 3

دیجیتال خودرو (مسئولیت محدود)
شرکت دیجیتال خودرو سامانه

اولین سامانه دیجیتال تعمیرکاران خودرو در ایران

AIR
CONDITIO
AIR BAG
SEAT
SUNROO
F
BODY
INTERIOR
BODY
EXTERIO
BODY
REPAIR

Modification basis	
Application basis	
Affected VIN	

4) Circuit Diagram

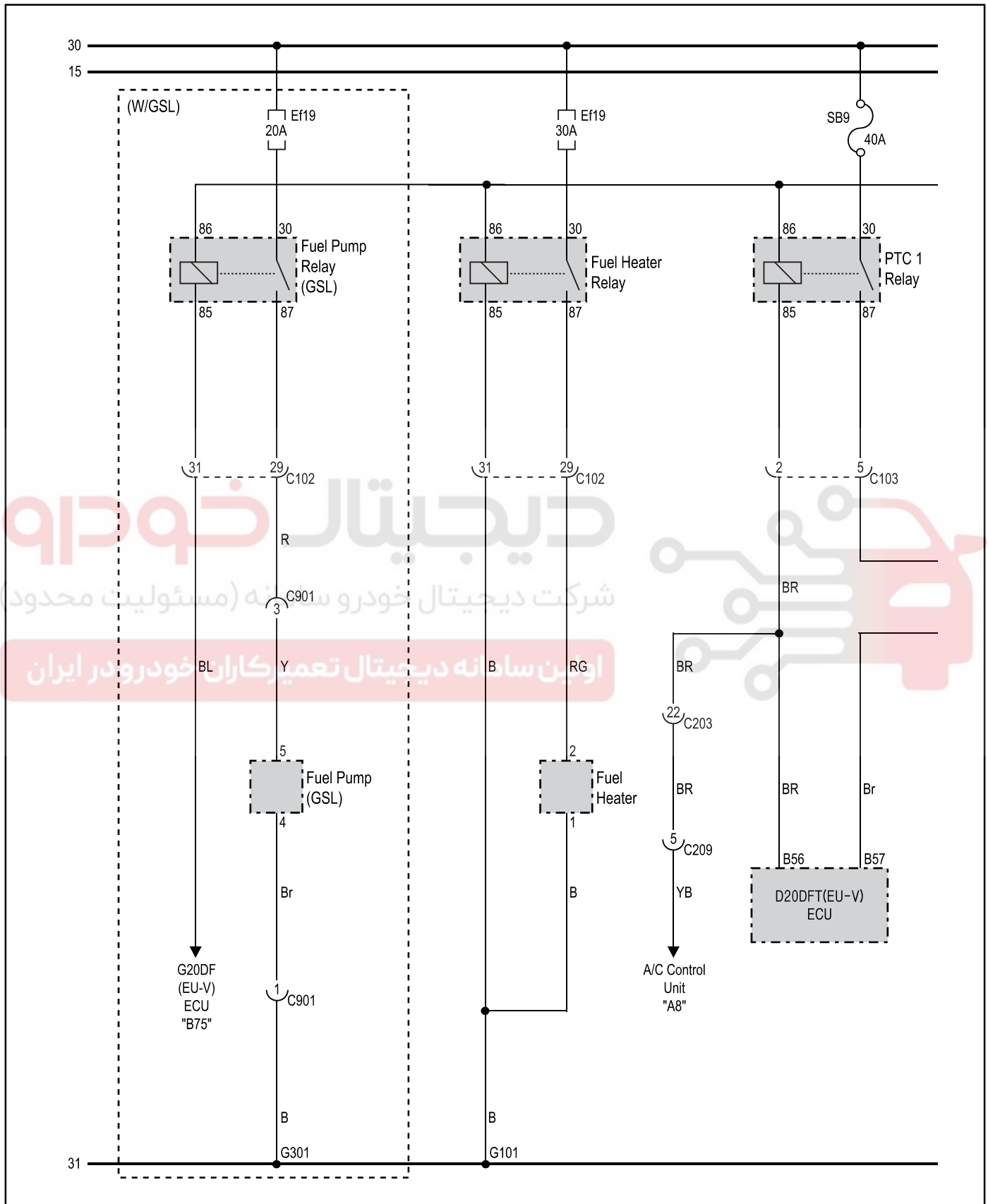

Modification basis	
Application basis	
Affected VIN	

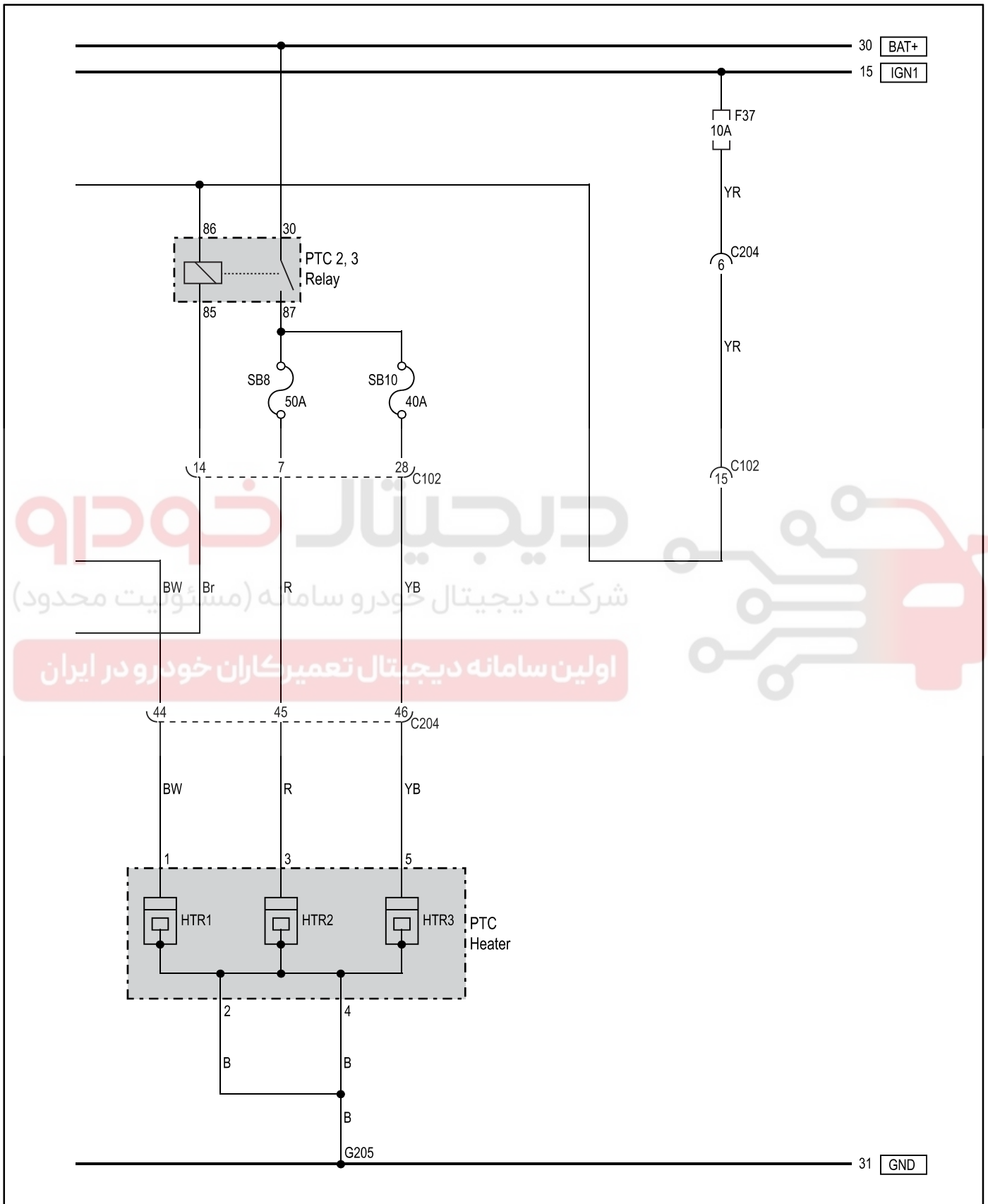

دیجیتال خودرو
 شرکت دیجیتال خودرو سامانه (مسئولیت محدود)
 اولین سامانه دیجیتال تعمیرکاران خودرو در ایران

Modification basis	
Application basis	
Affected VIN	

S.G.N. 6820-02 A/C COMPRESSOR

1) Overview

The A/C compressor, which is installed to the left side of the engine assembly, compresses the low-temperature and low-pressure coolant and converts it to the high-temperature and high-pressure coolant. Then, it sends the coolant to the A/C condenser. If the A/C operates, power is supplied to the magnetic clutch in the pulley and the driving force is transferred by the fan belt to compress the refrigerant. The engine ECU deactivates the A/C compressor in order to protect the A/C system in the event of A/C system overload.

2) Mounting Location & Components

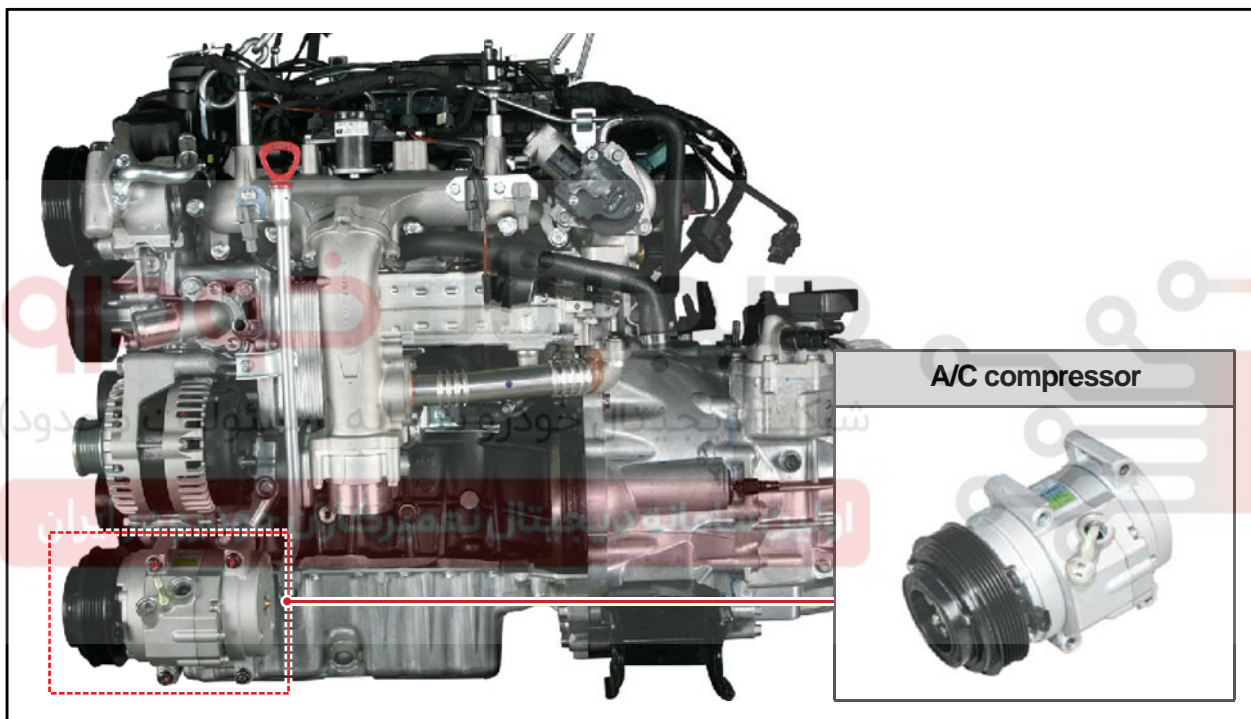

NOTE

Conditions for deactivating

- Coolant temperature: -20°C or less or 115°C or above
- For approx. 4 seconds after engine start
- Engine rpm: 650 rpm or less or 4500 rpm or above
- During abrupt acceleration
- Ambient temperature of 2°C or less
- Evaporator temperature of 2.5°C or less
- Refrigerant pressure in A/C refrigerant pressure sensor is
 - * Below 2.0 kg/cm^2 : OFF and rises to 2.4 kg/cm^2 or higher: ON
 - * 32 kg/cm^2 or higher: OFF and drops to below 26 kg/cm^2 : ON

Modification basis	
Application basis	
Affected VIN	

S.G.N.

6820-01 A/C CONDENSER

1) Overview

The A/C condenser is mounted in front of the front radiator and condenses vapor refrigerant into low temperature and high pressure liquid refrigerant. It has the built-in receiver drier, absorbs moisture in the refrigerant and reserves refrigerant to supply smoothly.

2) Mounting Location and Components

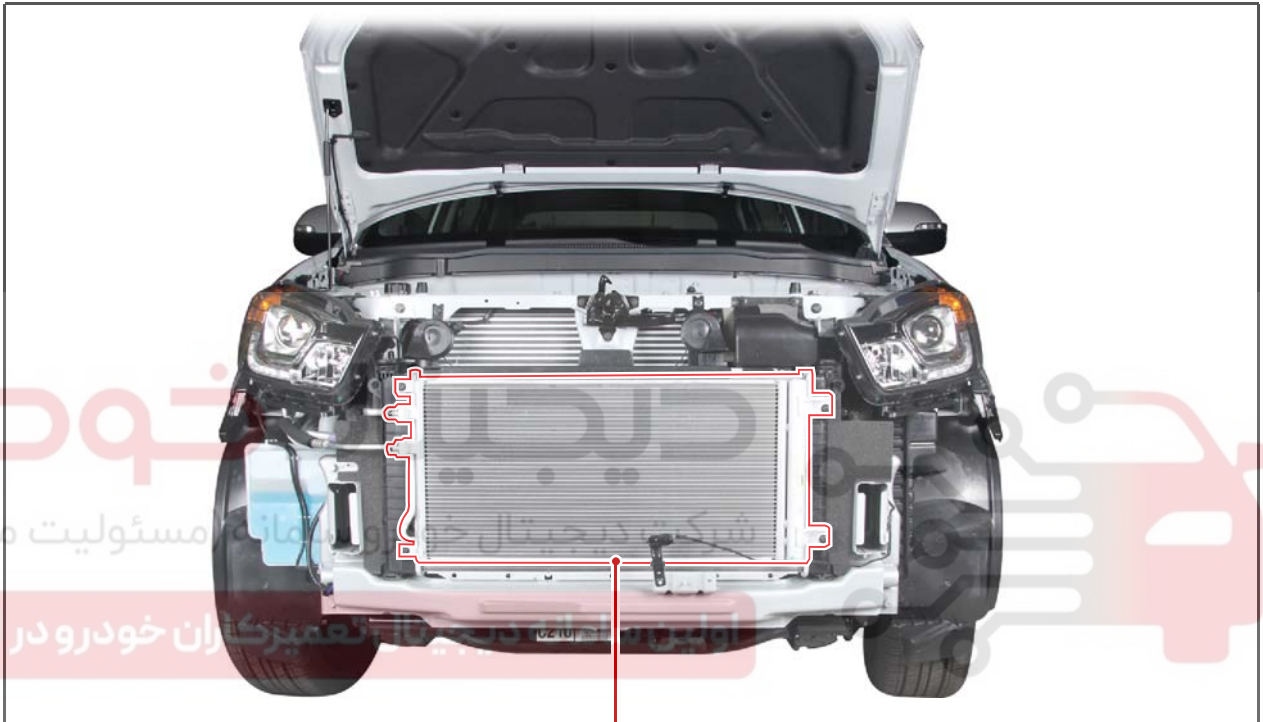

A/C condenser

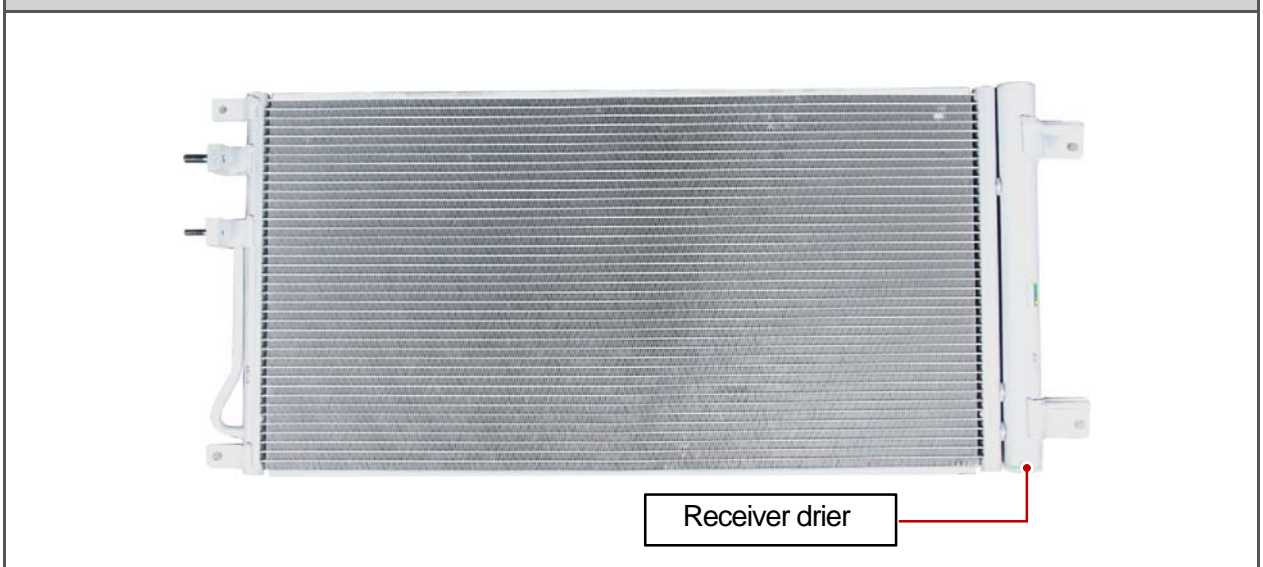

Receiver drier

- AIR CONDITIONING
- AIR BAG
- SEAT
- SUNROOF
- BODY INTERIOR
- BODY EXTERIOR
- BODY REPAIR

Modification basis	
Application basis	
Affected VIN	

REMOVAL AND INSTALLATION

6810-20 HEATER AND A/C CONTROL PANEL

Preceding work - Disconnect the negative battery cable.



NOTE

Remove and install the heater and A/C control assembly with FATC and one with MTC in the same way.



1. Remove the LH crash pad side cover.

Modification basis	
Application basis	
Affected VIN	



2. Unscrew the 2 mounting screws (A) and carefully pry off the lower main panel. Take care not to damage the clips (6 positions).

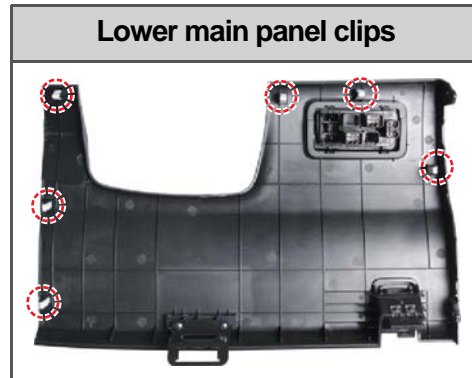

3. Disconnect the connections (A), (B), (C), (D), and (E) connected to the lower main panel.

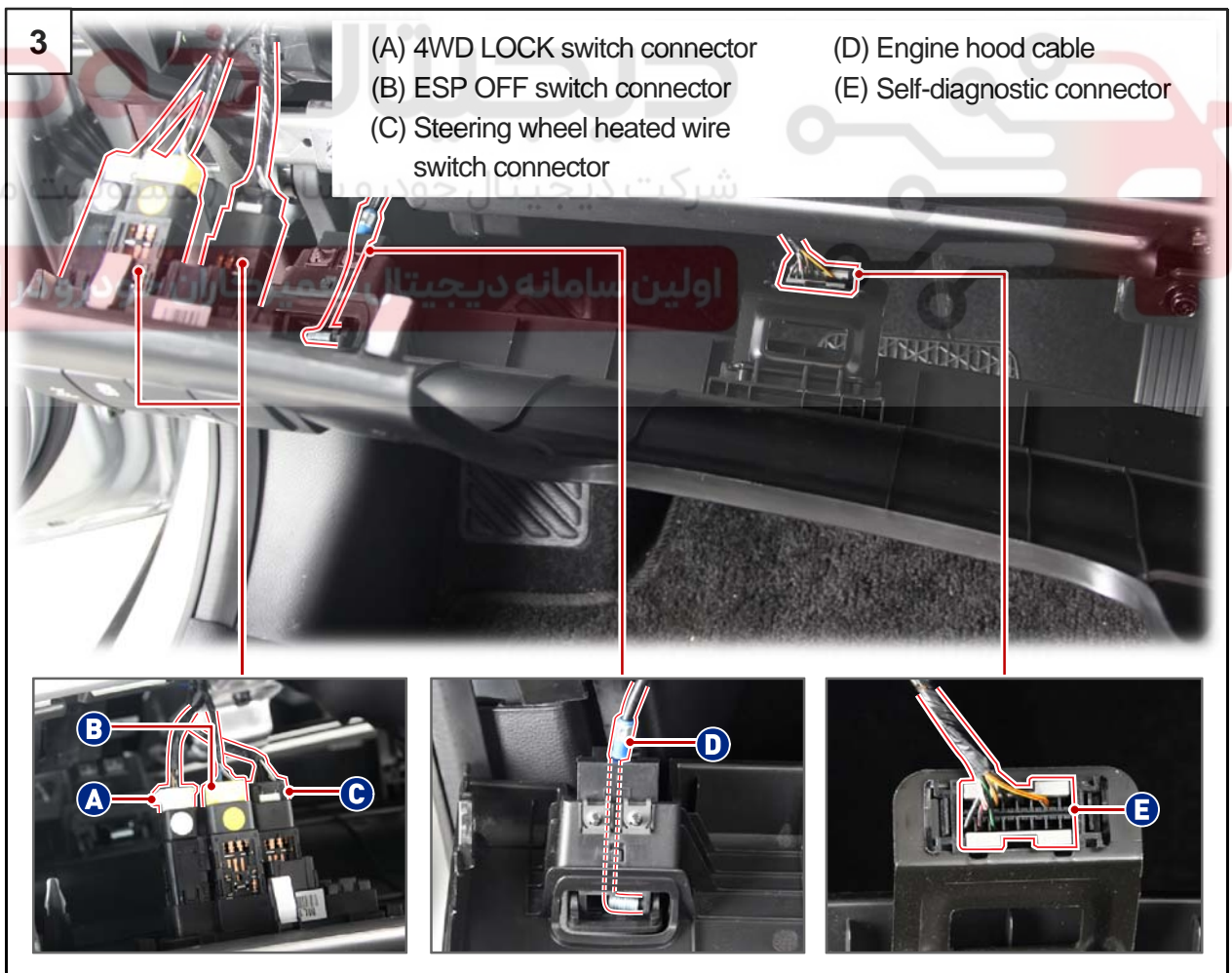

Modification basis	
Application basis	
Affected VIN	



4. Remove the lower main panel.



5. Carefully pry off the center fascia molding making sure not to damage the clips (2 positions).



6. Remove the center fascia molding.



7. Unscrew the LH center fascia panel mounting screw.

Modification basis	
Application basis	
Affected VIN	



8. Carefully pry off the LH center fascia panel making sure not to damage the clips (3 positions).

LH center fascia panel clips	
To IP	To component



9. Remove the LH center fascia panel.

Modification basis	
Application basis	
Affected VIN	



10. Remove the RH crash pad side cover.



11. Open the glove box and unscrew the 3 mounting screws securing the RH side fascia molding.



12. Pry off the part A to remove the RH side fascia molding. Take care not to damage the clips (8 off).

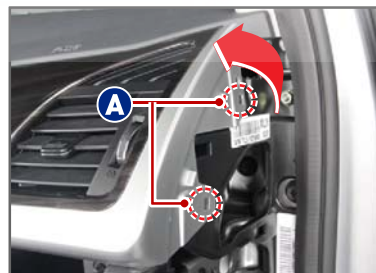

Side fascia molding clips	
To IP	To component

Modification basis	
Application basis	
Affected VIN	



13. Unscrew the RH center fascia panel mounting screw.



14. Carefully pry off the RH center fascia panel. Take care not to damage the clips (3 positions).

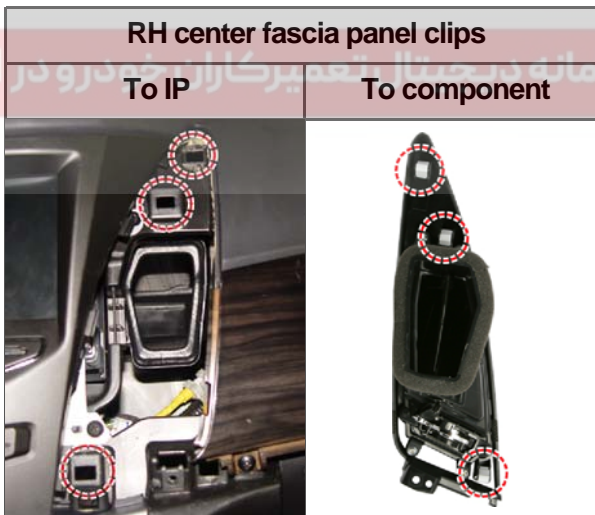

Modification basis	
Application basis	
Affected VIN	



15.Remove the RH center fascia panel.



16.Unscrew the 4 audio head unit mounting screws.

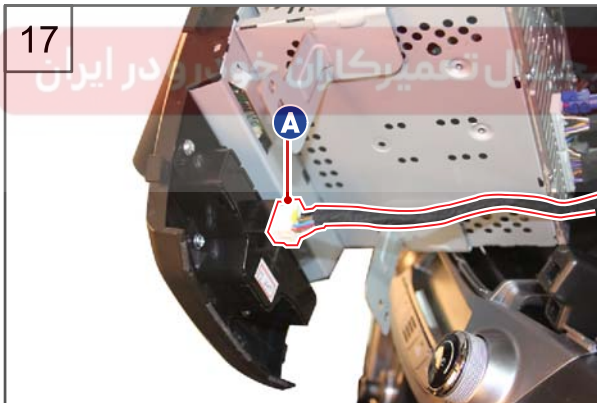

17.Lift off the audio head unit and disconnect the switch module connector (A).

Modification basis	
Application basis	
Affected VIN	

18. Disconnect the connectors (A), (B), (C), (D), (E), (F), and (G) from the audio head unit.

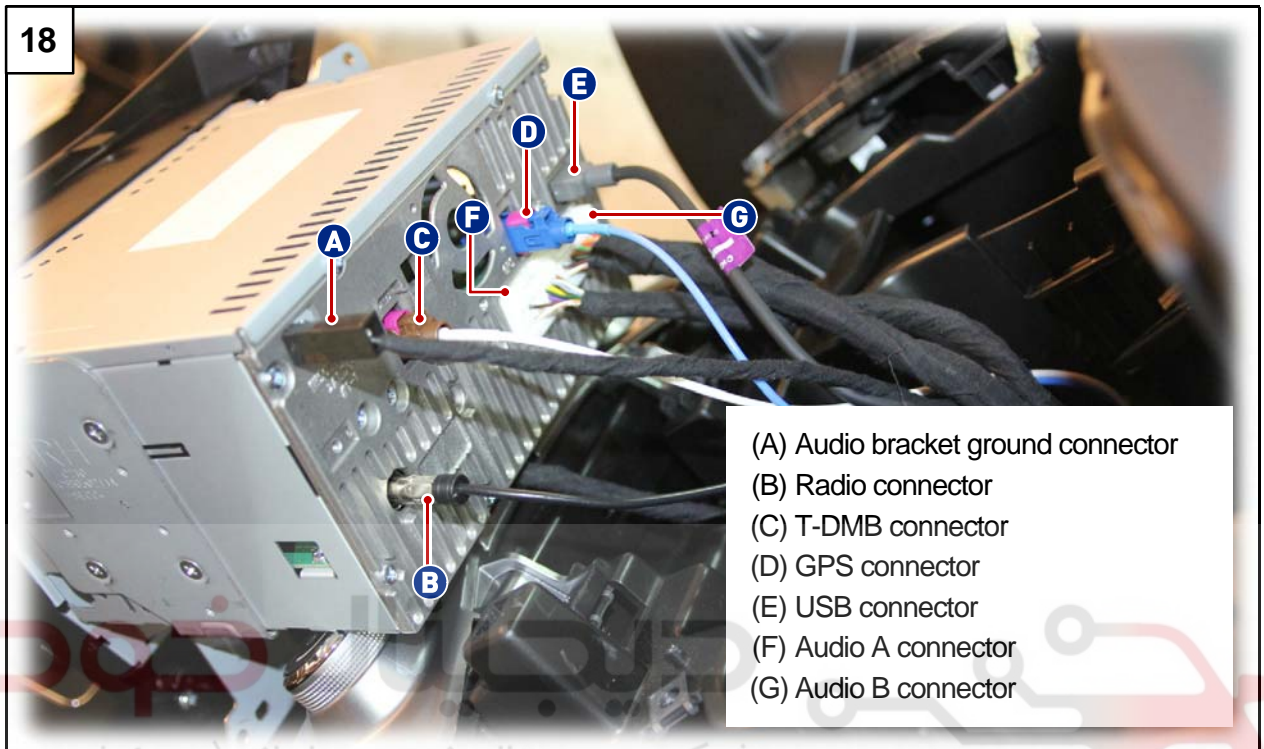

سركت ديگييال خودرو سامانه (مستوليت محدود)
اولين سامانه ديگي تال تهنگه كاري خودرو ايران



19. Remove the audio head unit.



20. Unscrew the 2 mounting screws securing the center fascia lower panel assembly.

Modification basis	
Application basis	
Affected VIN	



21. Carefully remove the center fascia lower panel assembly making sure not to damage the clips (4 positions).

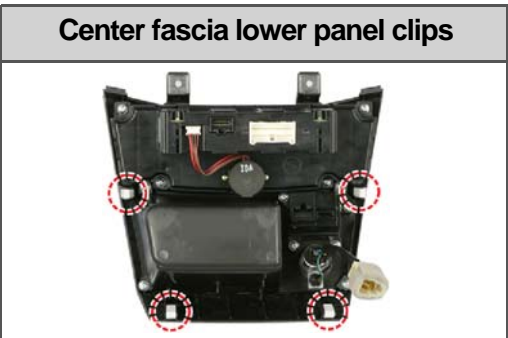

22. Disconnect the connectors (A), (B), (C), (D), and (E) connected to the center fascia lower panel assembly.

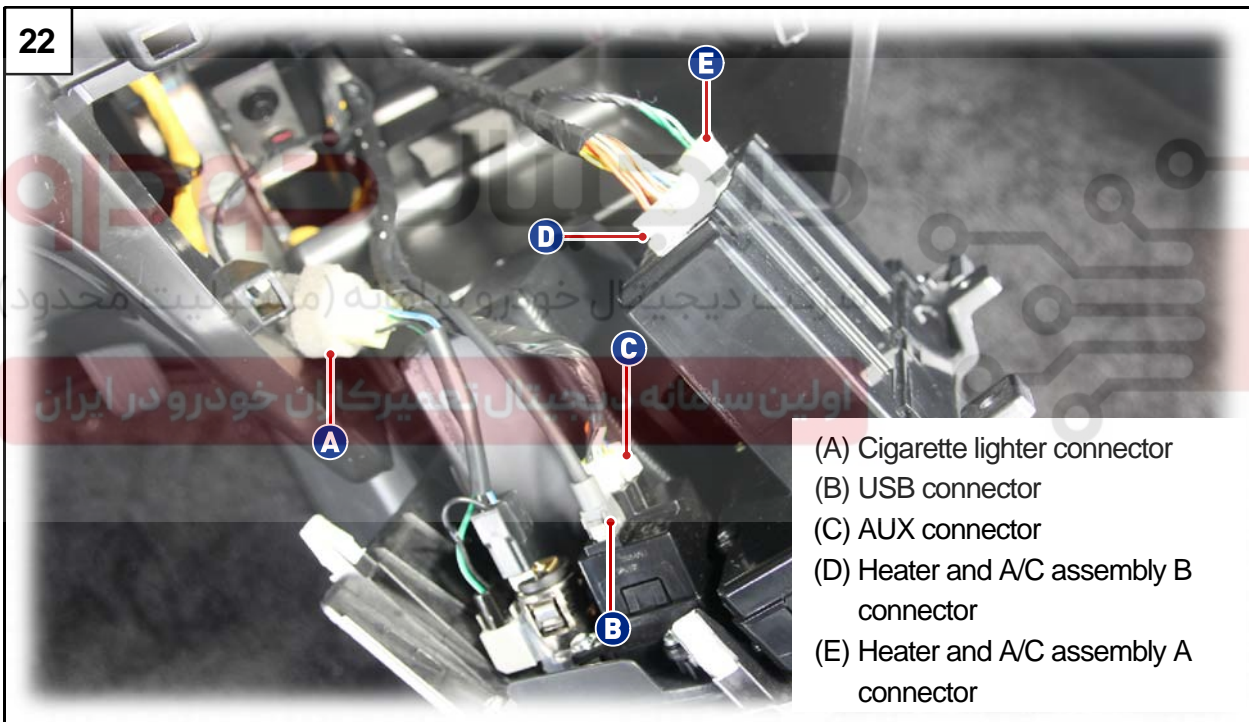

- (A) Cigarette lighter connector
- (B) USB connector
- (C) AUX connector
- (D) Heater and A/C assembly B connector
- (E) Heater and A/C assembly A connector



23. Remove the center fascia lower panel assembly.

Modification basis	
Application basis	
Affected VIN	



24. Unscrew the 4 mounting screws for the heater and A/C control assembly from the removed center fascia lower panel assembly.

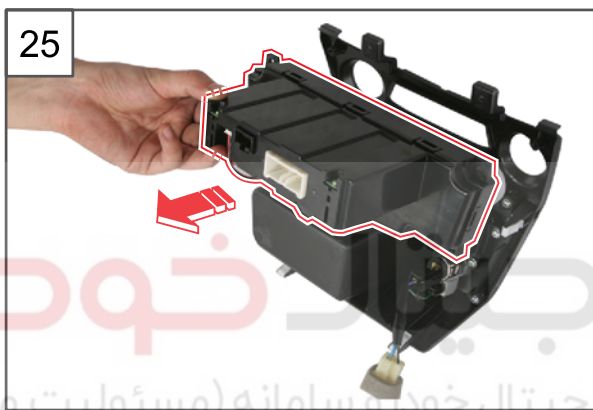

25. Remove the heater and A/C control assembly from the center fascia lower panel assembly.

26. Install in the reverse order of removal.



Modification basis	
Application basis	
Affected VIN	

S.G.N. **6810-10** AIR CONDITIONER MODULE

Preceding work

- Disconnect the negative battery cable.
- Drain the A/C refrigerant in a suitable container. Dispose the collected refrigerant as per local environmental guidelines.
- Drain the coolant from the radiator.



Air conditioner module



1. Remove the front console.

NOTE

Refer to "FRONT CONSOLE" under "REMOVAL AND INSTALLATION" in "BODY INTERIOR" chapter.

Modification basis	
Application basis	
Affected VIN	

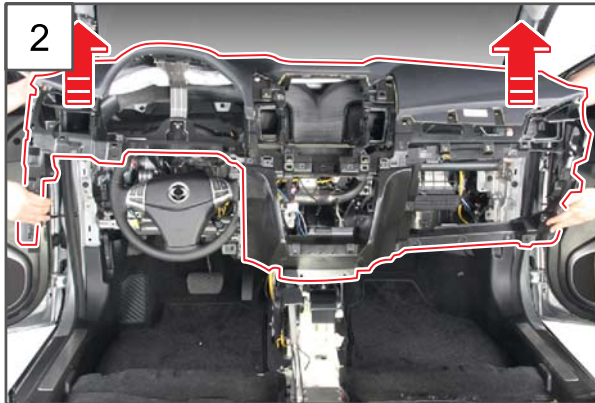

2. Remove the instrument panel.

NOTE

Refer to "Removal and installation, Instrument panel" section of "Body Interior".

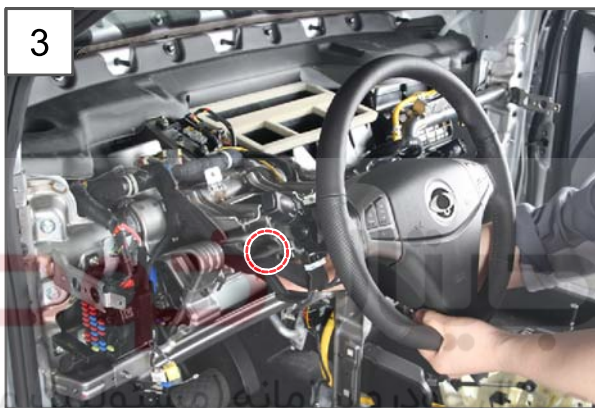

3. Temporarily fit the steering wheel with column shaft adjusted to make room for working using the 2 front mounting nuts when removing the instrument panel.

NOTE

This manual describes the procedure of the steering column shaft in a vehicle with EPS.

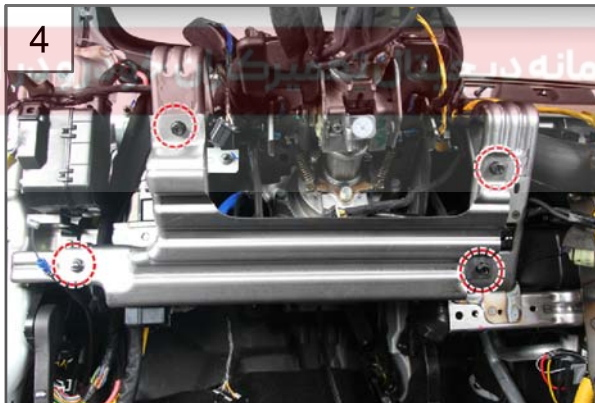

4. Unscrew the 4 mounting bolts and nuts (10 mm) to remove the knee bolster bracket.

Modification basis	
Application basis	
Affected VIN	

5. Disconnect the connectors (A), (B), (C), (D), (E), and (F) from the bottom of the steering wheel.

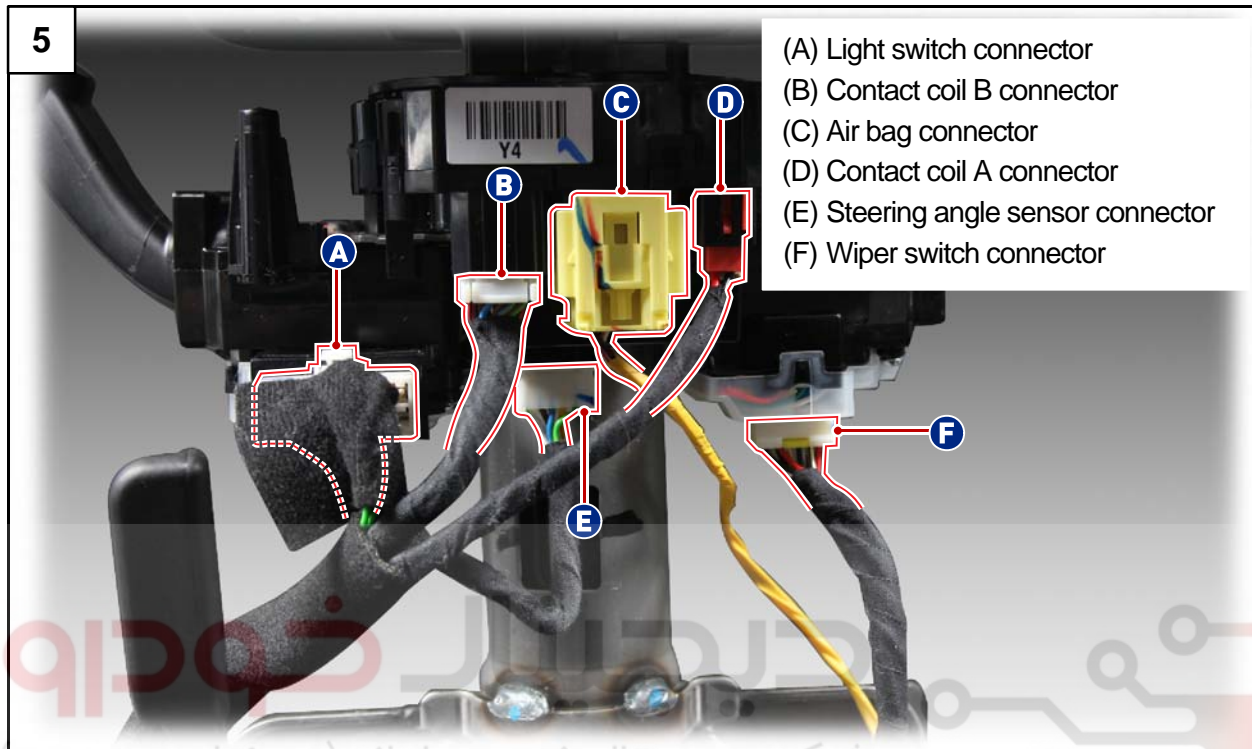

6. Remove the 3 wiring mounting keys (A) and disconnect the connector (B) on the EPS unit side.

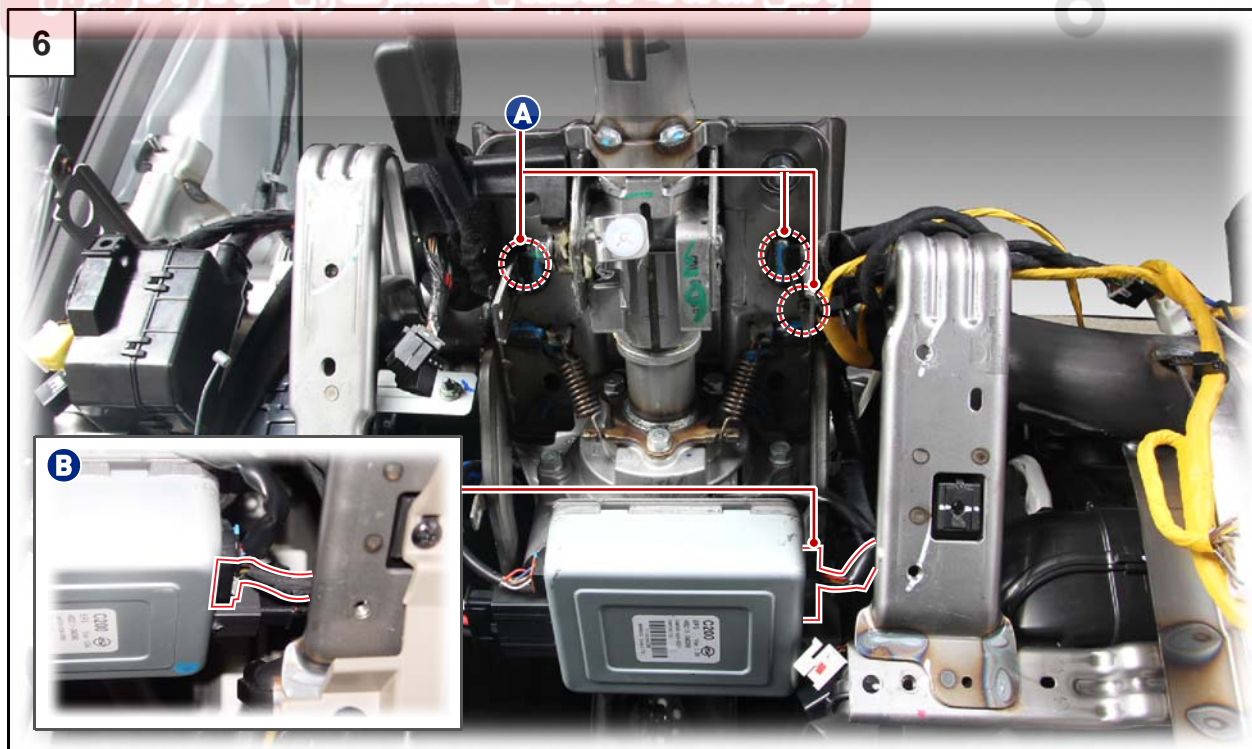

Modification basis	
Application basis	
Affected VIN	

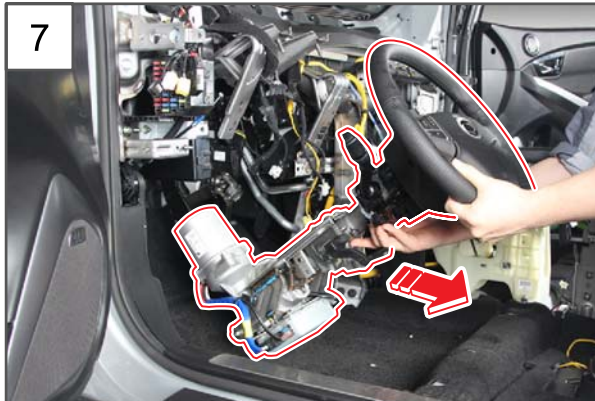

7. Unscrew the mounting nuts that were tightened temporarily to remove the steering wheel and column shaft assembly.



8. Remove the front door scuff trims on the driver and passenger sides.

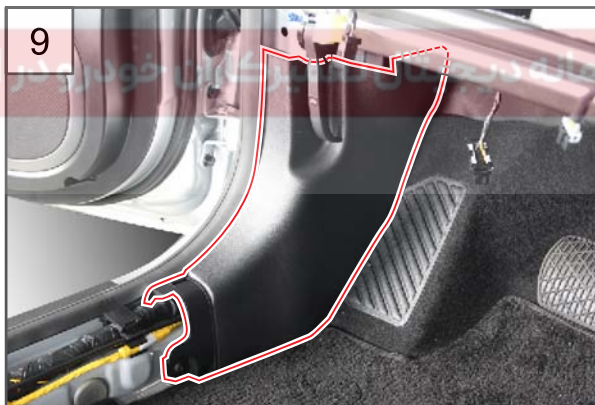

9. Remove the cowl side trims on the driver and passenger sides.

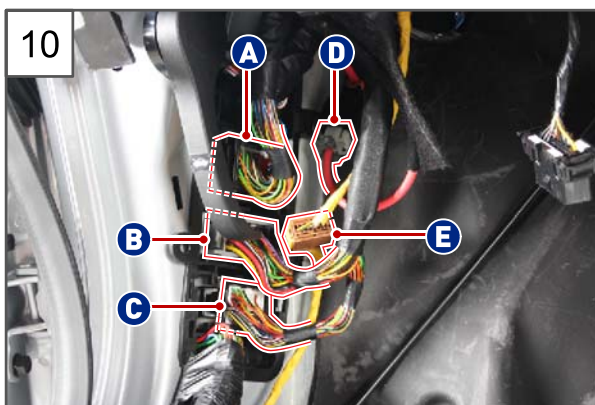

10. Disconnect the connectors (A), (B), (C), (D), and (E) from the cowl side on the driver side.

Modification basis	
Application basis	
Affected VIN	

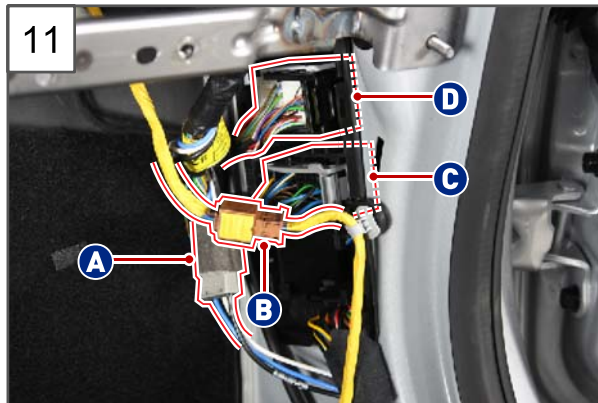

11. Disconnect the connectors (A), (B), (C) and (D) from the cowl side on the passenger side.

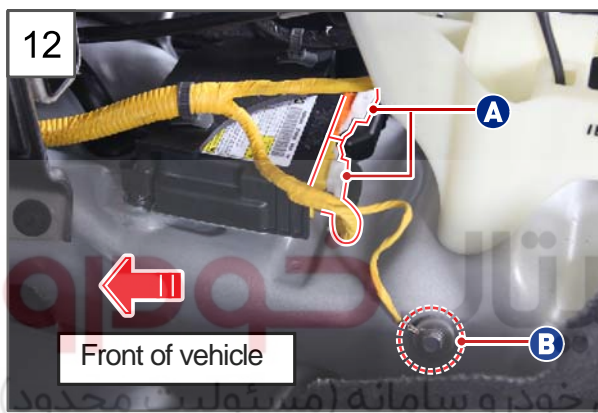

12. Disconnect the 2 SDM connectors (A) in front of the TGS lever and unscrew the ground mounting bolt (B, 10 mm).

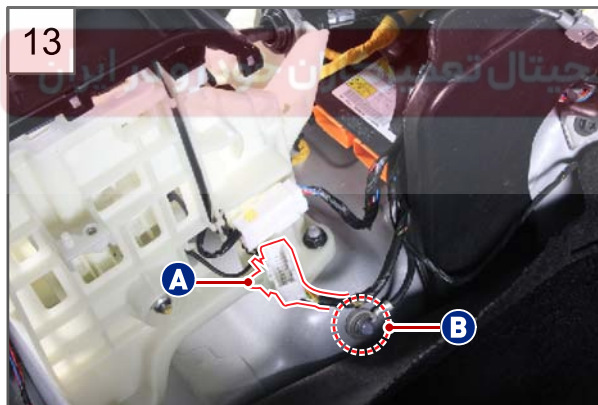

13. Disconnect the connector (A) for the TGS lever and unscrew the ground mounting bolt (B, 10 mm).

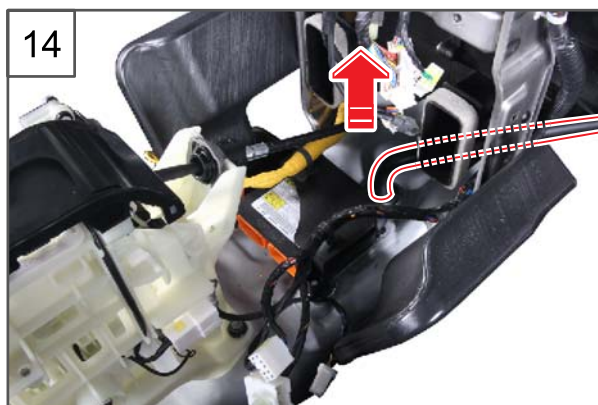

14. Remove the drain hose for A/C from the vehicle body.

Modification basis	
Application basis	
Affected VIN	

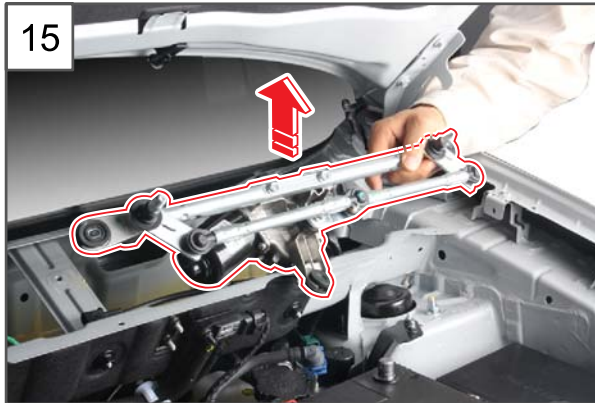

15.Remove the front wiper motor and linkage.

NOTE

Refer to "FRONT WIPER MOTOR" under "REMOVAL AND INSTALLATION" in "WIPER SYSTEM" chapter.

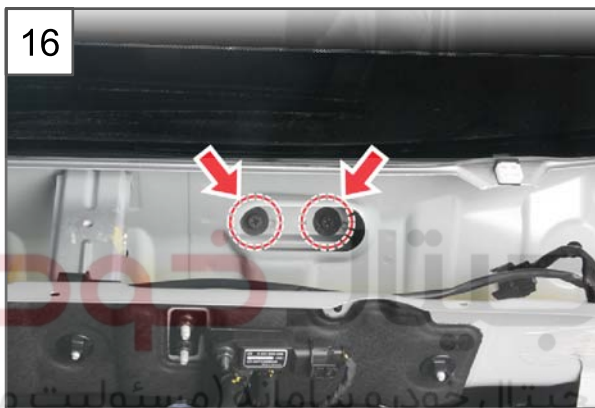

16.Unscrew the 2 mounting bolts (10 mm) on the dash panel securing the instrument panel frame.

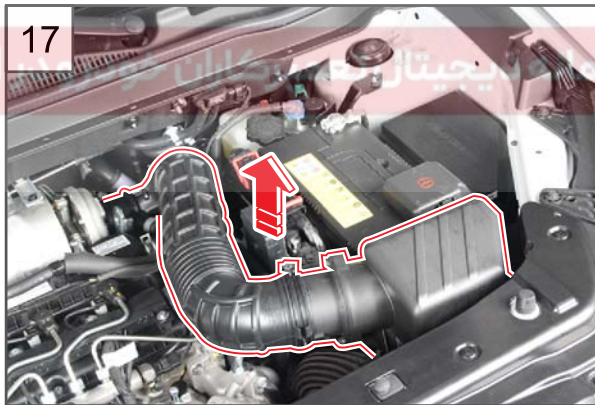

17.Remove the air cleaner duct hose to make room for working.



18.Unscrew the 2 mounting nuts (10 mm) for the differential pressure sensor.

Modification basis	
Application basis	
Affected VIN	

19. Unscrew the 6 mounting nuts for the partition insulator from the engine compartment and the bottom of the vehicle.

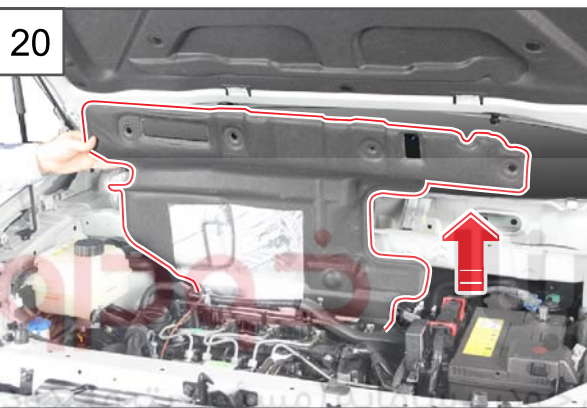

20. Remove the partition insulator from the engine compartment.

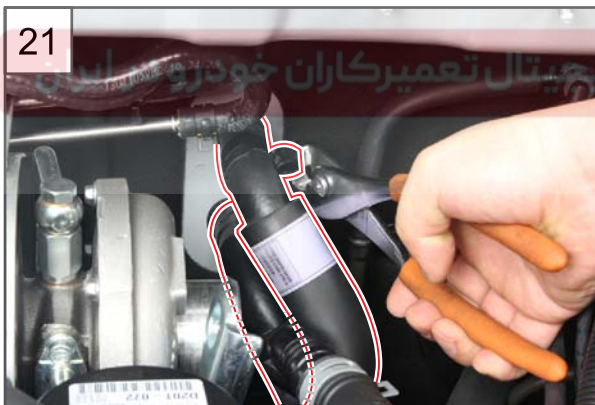
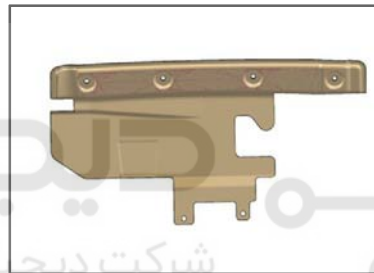

21. Disconnect the heater inlet and outlet hoses.



22. Unscrew the mounting nut (12 mm) securing the expansion valve and A/C suction & liquid pipe.

Modification basis	
Application basis	
Affected VIN	



23. Unscrew the 2 A/C module mounting bolts (10 mm) from the heater pipe and expansion valve sides.



دیگرو (شرکت دیجیتال خودرو سامانه) (با محدود)



اولین سامانه دیجیتال تعمیرکاران خودرو در ایران

- AIR CONDITIONING
- AIR BAG
- SEAT
- SUNROOF
- BODY INTERIOR
- BODY EXTERIOR
- BODY REPAIR

Modification basis	
Application basis	
Affected VIN	

24. Unscrew the instrument panel frame mounting bolts fitted to the body.

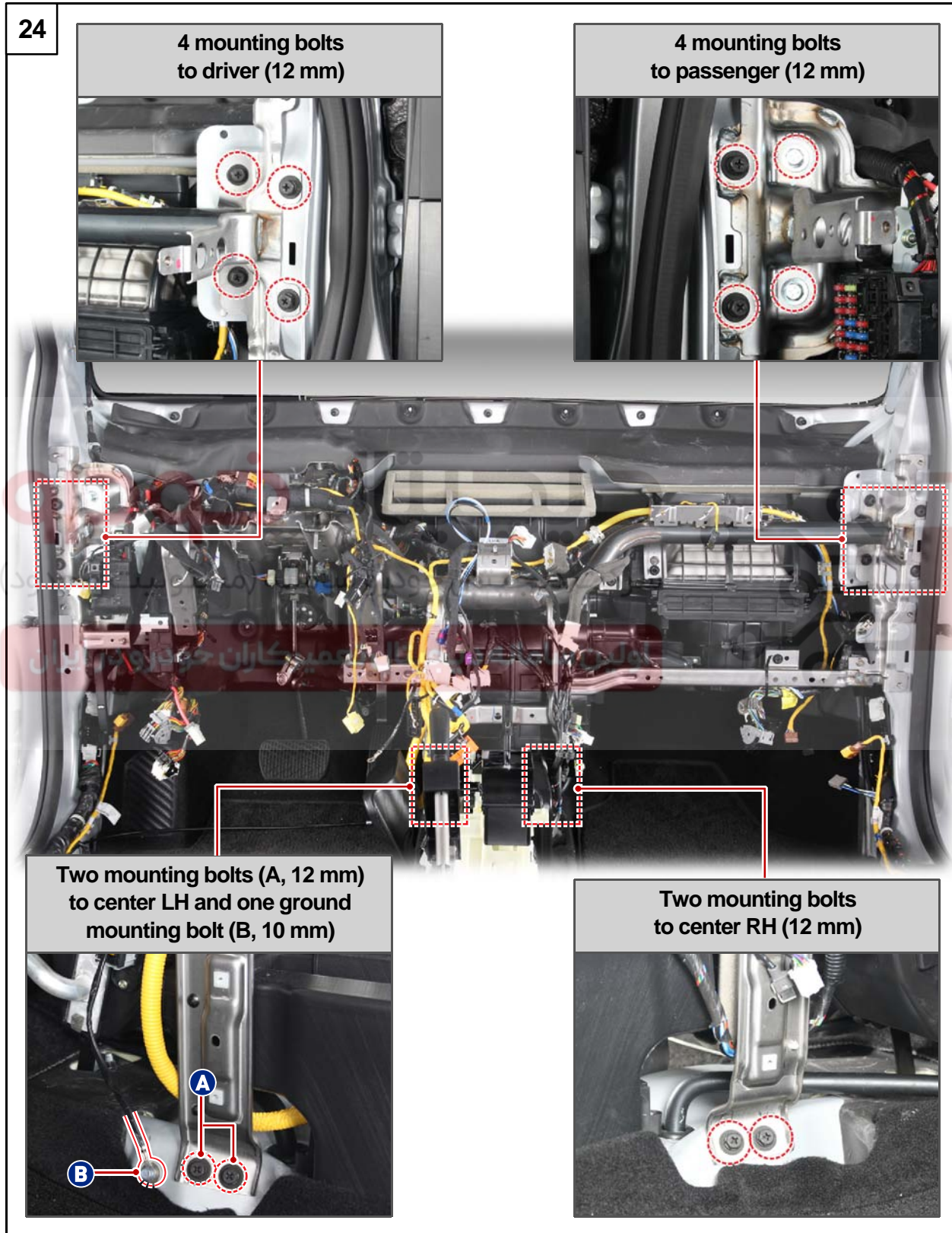

Modification basis	
Application basis	
Affected VIN	



25. Remove the instrument panel frame & air conditioner module.

26. Unscrew the air conditioner module mounting bolt and mounting screw fitted to the instrument panel frame and disconnect the wiring connector.

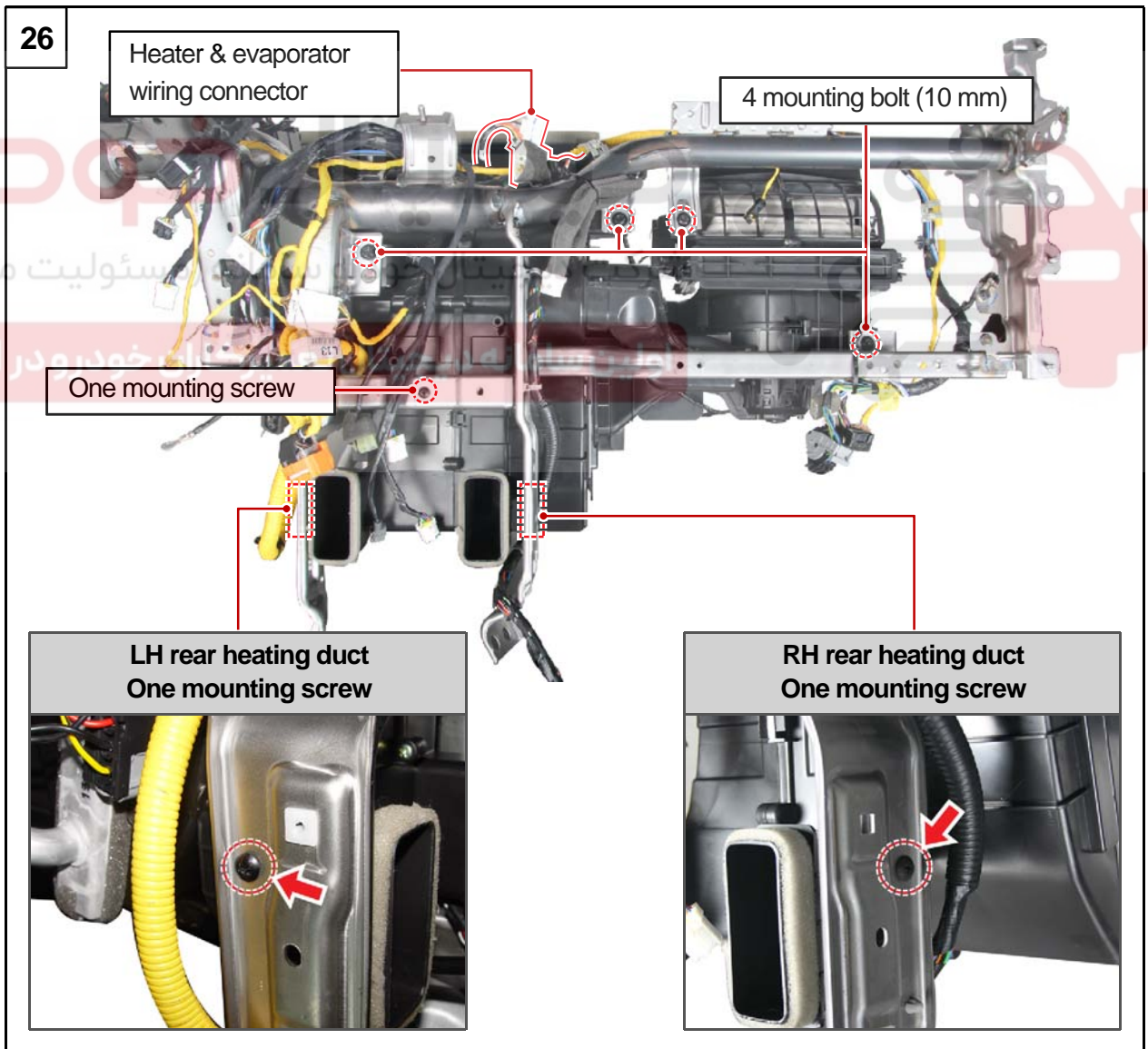

Modification basis	
Application basis	
Affected VIN	

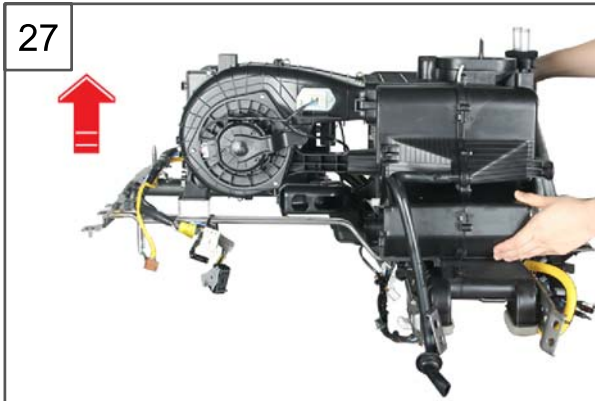

27.Remove the air conditioner module from the instrument panel frame.

28.Install in the reverse order of removal.

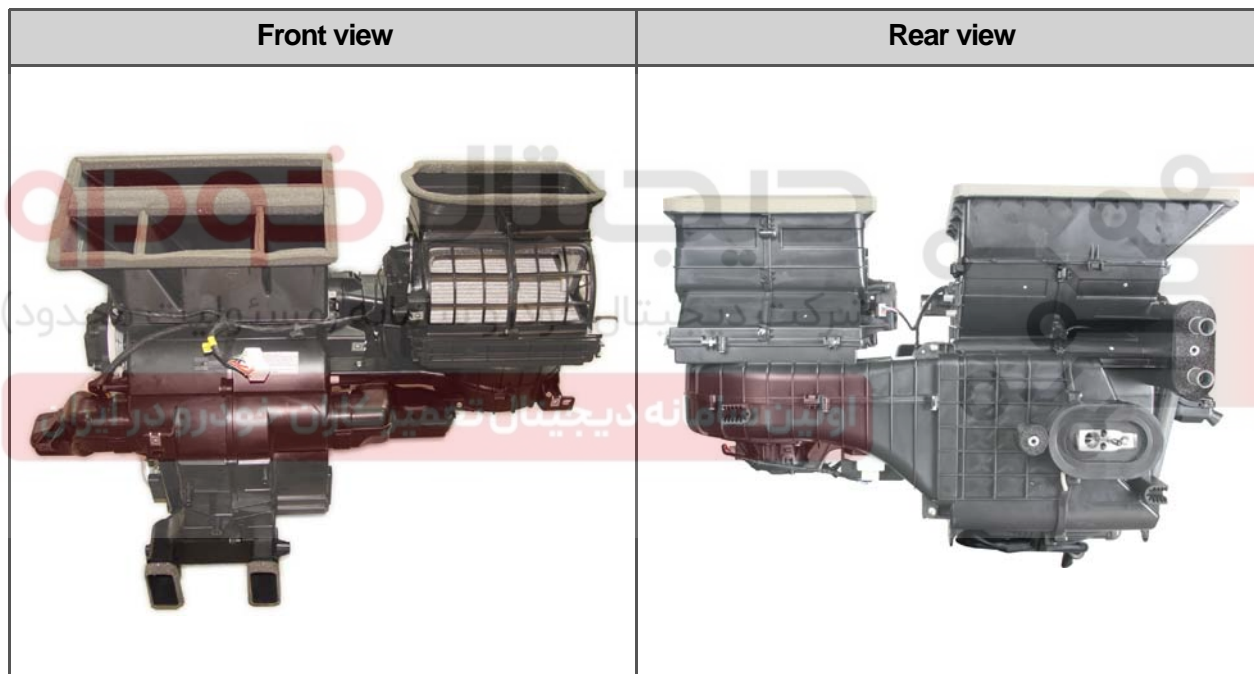

Modification basis	
Application basis	
Affected VIN	

S.G.N.
6810-13 HEATER CORE

Preceding work

- Disconnect the negative battery cable.
- Drain the A/C refrigerant in a suitable container. Dispose the collected refrigerant as per local environmental guidelines.
- Drain the coolant from the radiator.



شرکت دیجیتال خودرو (مسئولیت محدود)
اولین سامانه ریتار و تعمیرکار خودرو ایران



1. Remove the front console.

NOTE

Refer to "FRONT CONSOLE" under "REMOVAL AND INSTALLATION" in "BODY INTERIOR" chapter.

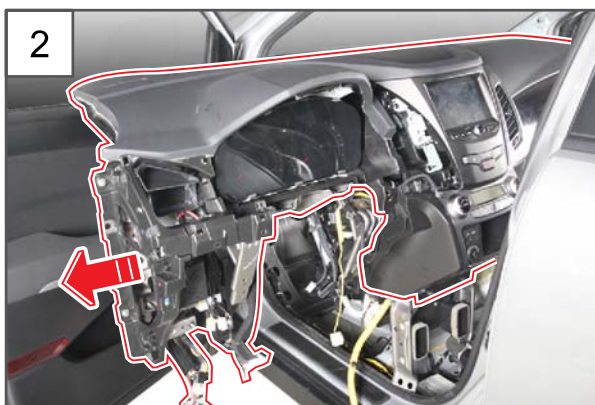

2. Remove the IP and A/C module.

NOTE

Refer to "IP AND A/C MODULE" under "REMOVAL AND INSTALLATION" in "BODY INTERIOR".

Modification basis	
Application basis	
Affected VIN	

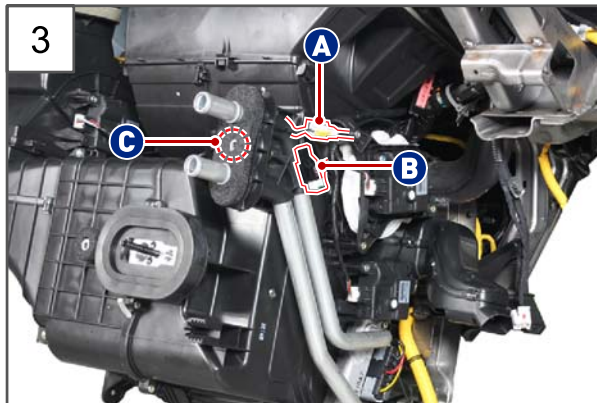

3. Remove the water temperature sensor connector (A) and intake sensor connector sliding fastener (B) and unscrew the one heater pipe cover mounting screw (C).



4. Remove the heater pipe cover.

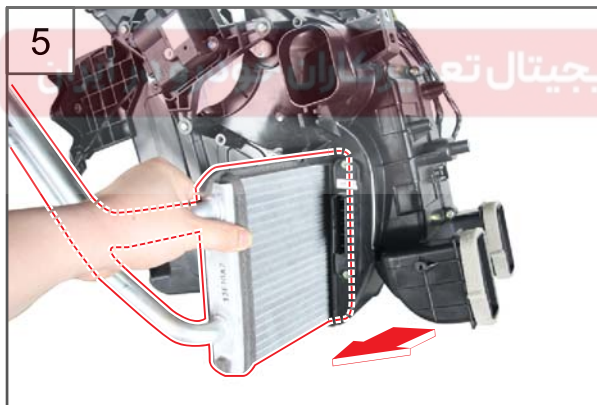

5. Remove the heater core.



6. Install in the reverse order of removal.

Modification basis	
Application basis	
Affected VIN	

S.G.N.
6810-12 MODE ACTUATOR

Preceding work - Disconnect the negative battery cable.



دیجیتال خودرو
شرکت دیجیتال خودرو سامانه (مسئولیت محدود)
اولین سامانه در کشور ایران

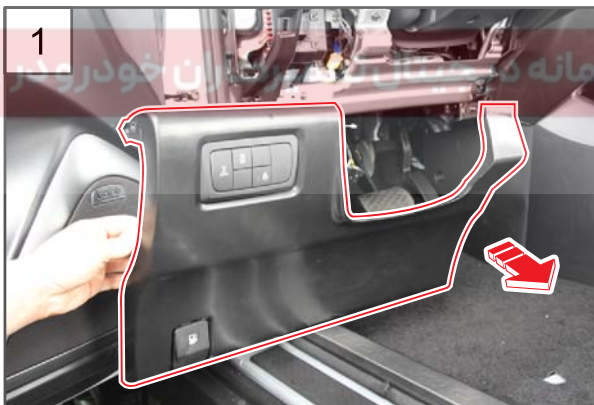

1. Remove the lower main panel.

NOTE

Refer to "LOWER MAIN PANEL" under "REMOVAL AND INSTALLATION" in "BODY INTERIOR" chapter.

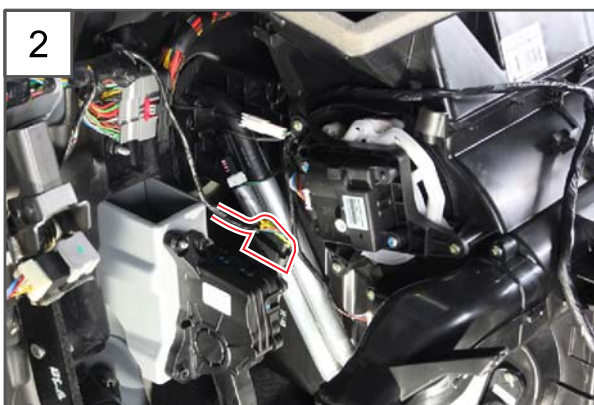

2. Disconnect the mode actuator connector from inside of the instrument panel.

Modification basis	
Application basis	
Affected VIN	



3. Unscrew the two mode actuator mounting screws.



4. Remove the mode actuator.



5. Install in the reverse order of removal.

Modification basis	
Application basis	
Affected VIN	

S.G.N. **6810-02 INTAKE ACTUATOR**

Preceding work - Disconnect the negative battery cable.



- AIR CONDITIONING
- AIR BAG
- SEAT
- SUNROOF
- BODY INTERIOR
- BODY EXTERIOR
- BODY REPAIR

دیجیتال خودرو
 شرکت دیجیتال خودرو سامانه (مسئولیت محدود)
 اولین سامانه دیجیتال خودرو ایران

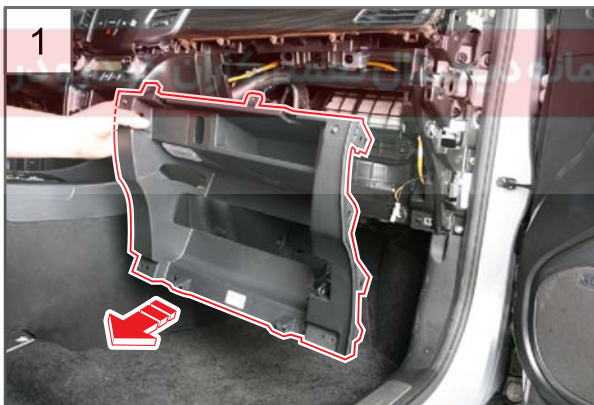

1. Remove the glove box housing.

NOTE
 Refer to "GLOVE BOX HOUSING" under "REMOVAL AND INSTALLATION" in "BODY INTERIOR".

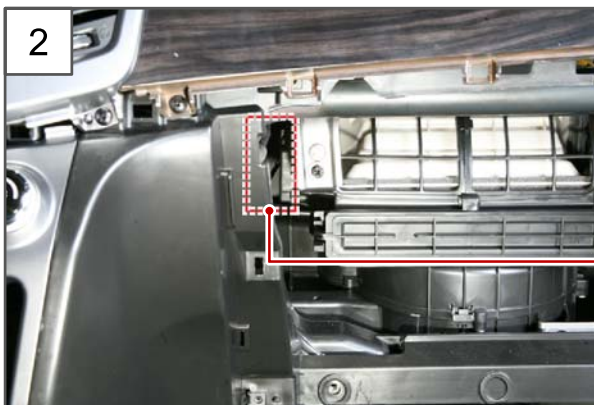

2. Unscrew the two intake actuator mounting screws in the instrument panel.



Modification basis	
Application basis	
Affected VIN	



3. Lift off the intake actuator and disconnect the connector.

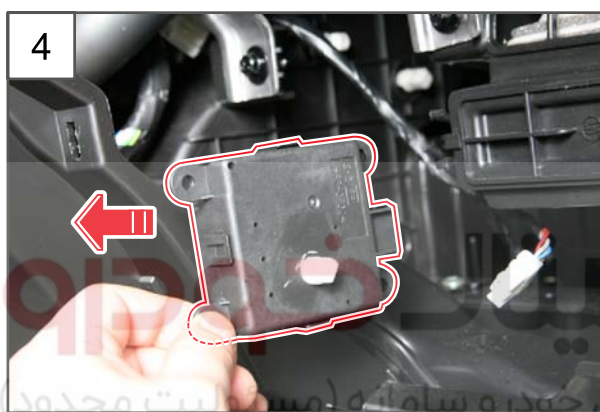

4. Remove the intake actuator.



5. Install in the reverse order of removal.

Modification basis	
Application basis	
Affected VIN	

S.G.N.
6810-11 TEMP ACTUATOR

Preceding work - Disconnect the negative battery cable.

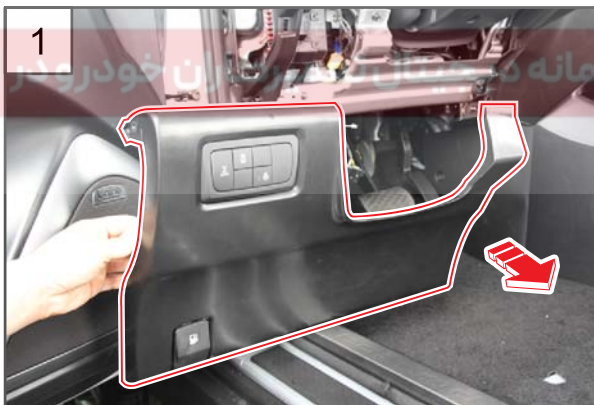
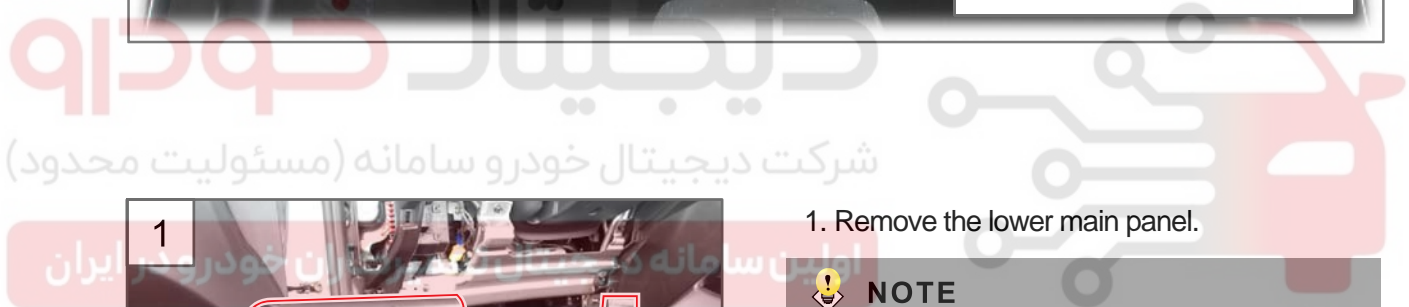

1. Remove the lower main panel.

NOTE

Refer to "LOWER MAIN PANEL" under "REMOVAL AND INSTALLATION" in "BODY INTERIOR" chapter.



2. Disconnect the temp actuator connector from inside of the instrument panel.

Modification basis	
Application basis	
Affected VIN	

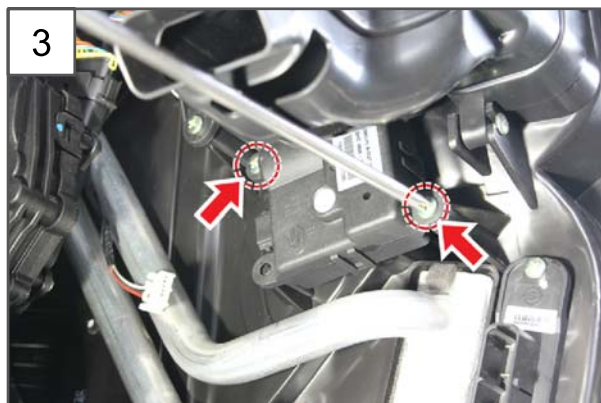

3. Unscrew the two temperature actuator mounting screws.



4. Remove the temp actuator.



5. Install in the reverse order of removal.

Modification basis	
Application basis	
Affected VIN	

S.G.N.
6810-23 INCAR SENSOR

Preceding work - Disconnect the negative battery cable.



دیجیتال خودرو
شرکت دیجیتال خودرو سامانه (مسئولیت محدود)
تولید سامانه دیجیتال خودرو در ایران



1. Remove the center fascia lower panel assembly.

NOTE
Refer to "HEATER AND A/C CONTROL ASSEMBLY" under "REMOVAL AND INSTALLATION" in "AIR CONDITIONING SYSTEM".

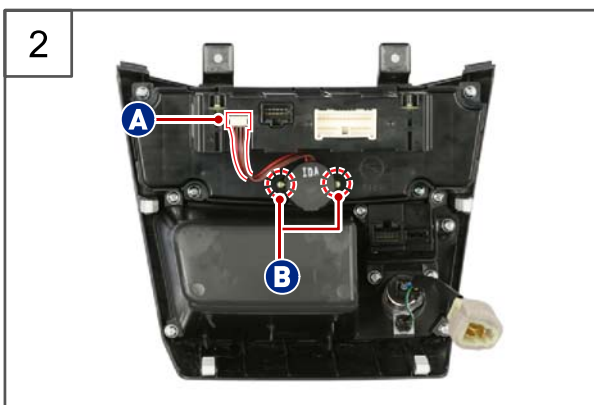

2. Disconnect the connector A from rear of the center fascia lower panel assembly and unscrew the 2 mounting screws (B) to remove the incar sensor.

3. Install in the reverse order of removal.

Modification basis	
Application basis	
Affected VIN	

AIR CONDITIO
AIR BAG
SEAT
SUNROO
F
BODY INTERIOR
BODY EXTERIO
BODY REPAIR

S.G.N. **6810-00 WATER TEMPERATURE SENSOR**

Preceding work - Disconnect the negative battery cable.



شرکت دیجیتال خودرو (مسئولیت محدود)

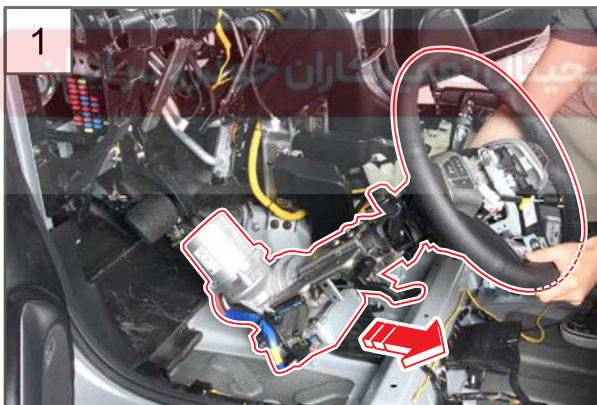

1. Remove the steering wheel and column shaft assembly.

NOTE

Refer to "STEERING COLUMN SHAFT" under "REMOVAL AND INSTALLATION" in "STEERING SYSTEM & EPS SYSTEM".

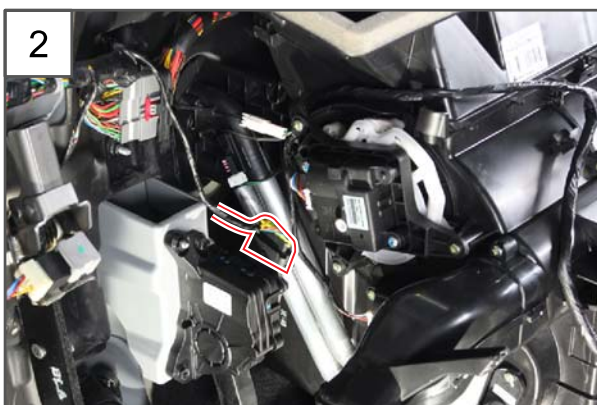

2. Disconnect the accelerator pedal module connector.

Modification basis	
Application basis	
Affected VIN	

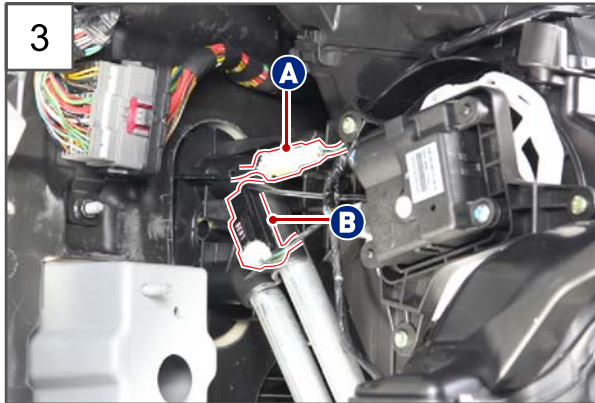

3. Disconnect the water temperature sensor connector A in front of the mode actuator and slide the intake sensor connector B fixed to the heater pipe cover to the arrow direction to remove it.



4. Unscrew the one mounting screw on the heater pipe cover.

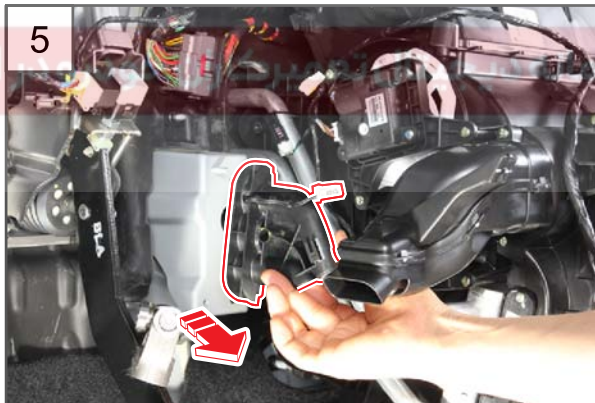

5. Remove the heater pipe cover.



6. Remove the water temperature sensor from the heater pipe cover.



Modification basis	
Application basis	
Affected VIN	

01-114 6810-00

KORANDO



7. Install in the reverse order of removal.

دیجیتال خودرو

شرکت دیجیتال خودرو سامانه (مسئولیت محدود)

اولین سامانه دیجیتال تعمیرکاران خودرو در ایران



Modification basis	
Application basis	
Affected VIN	

S.G.N.
6810-24 INTAKE SENSOR

Preceding work

- Disconnect the negative battery cable.
- Drain the A/C refrigerant in a suitable container. Dispose the collected refrigerant as per local environmental guidelines.
- Drain the coolant from the radiator.

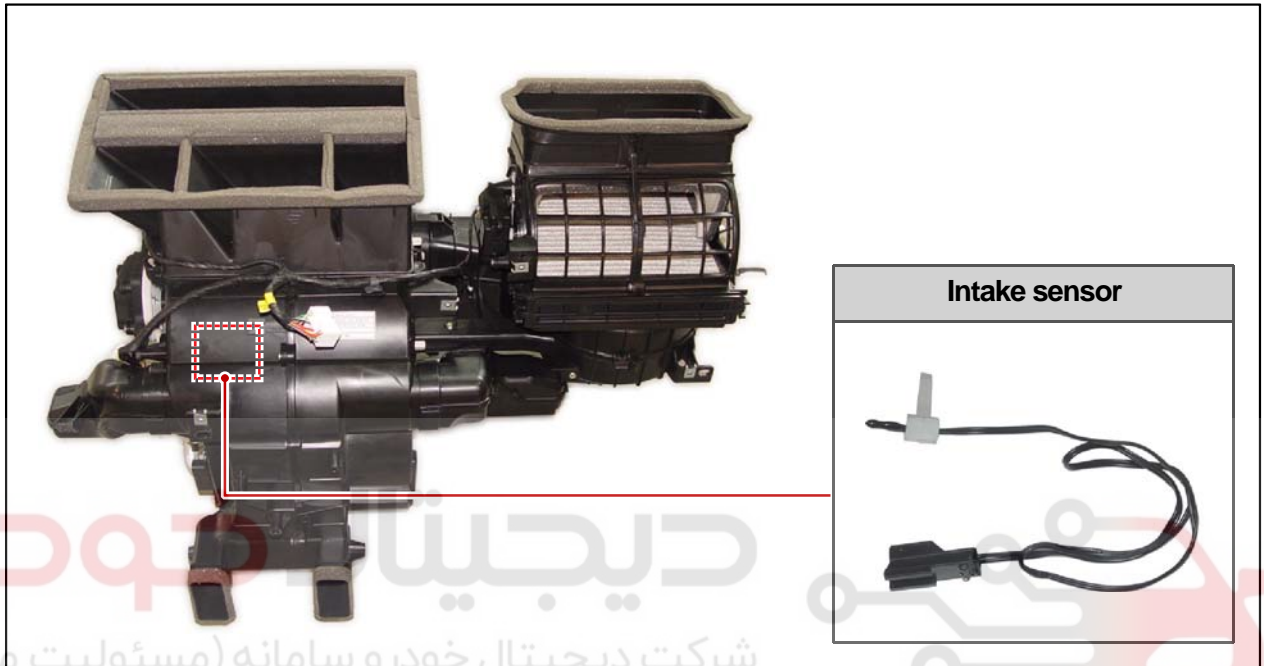

1. Remove the front console.

NOTE

Refer to "FRONT CONSOLE" under "REMOVAL AND INSTALLATION" in "BODY INTERIOR" chapter.

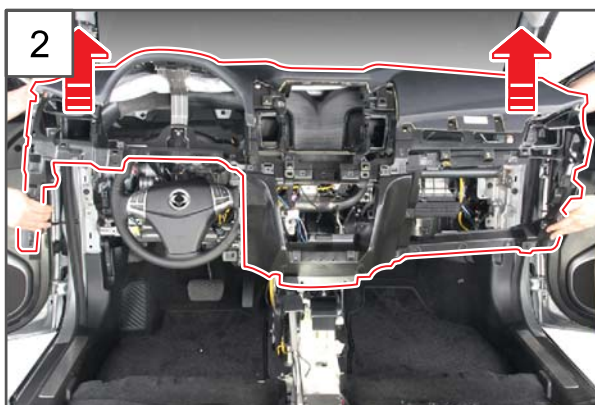

2. Remove the instrument panel.

NOTE

Refer to "Removal and installation, Instrument panel" section of "Body Interior".

Modification basis	
Application basis	
Affected VIN	

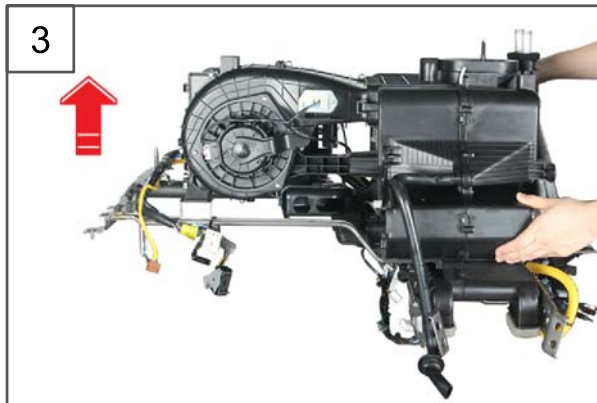

3. Remove the air conditioner module from the instrument panel frame.



NOTE

Refer to "AIR CONDITIONER MODULE" under "REMOVAL AND INSTALLATION" in "AIR CONDITIONING SYSTEM" chapter.

4. Remove the peripheral equipments from the air conditioner module.

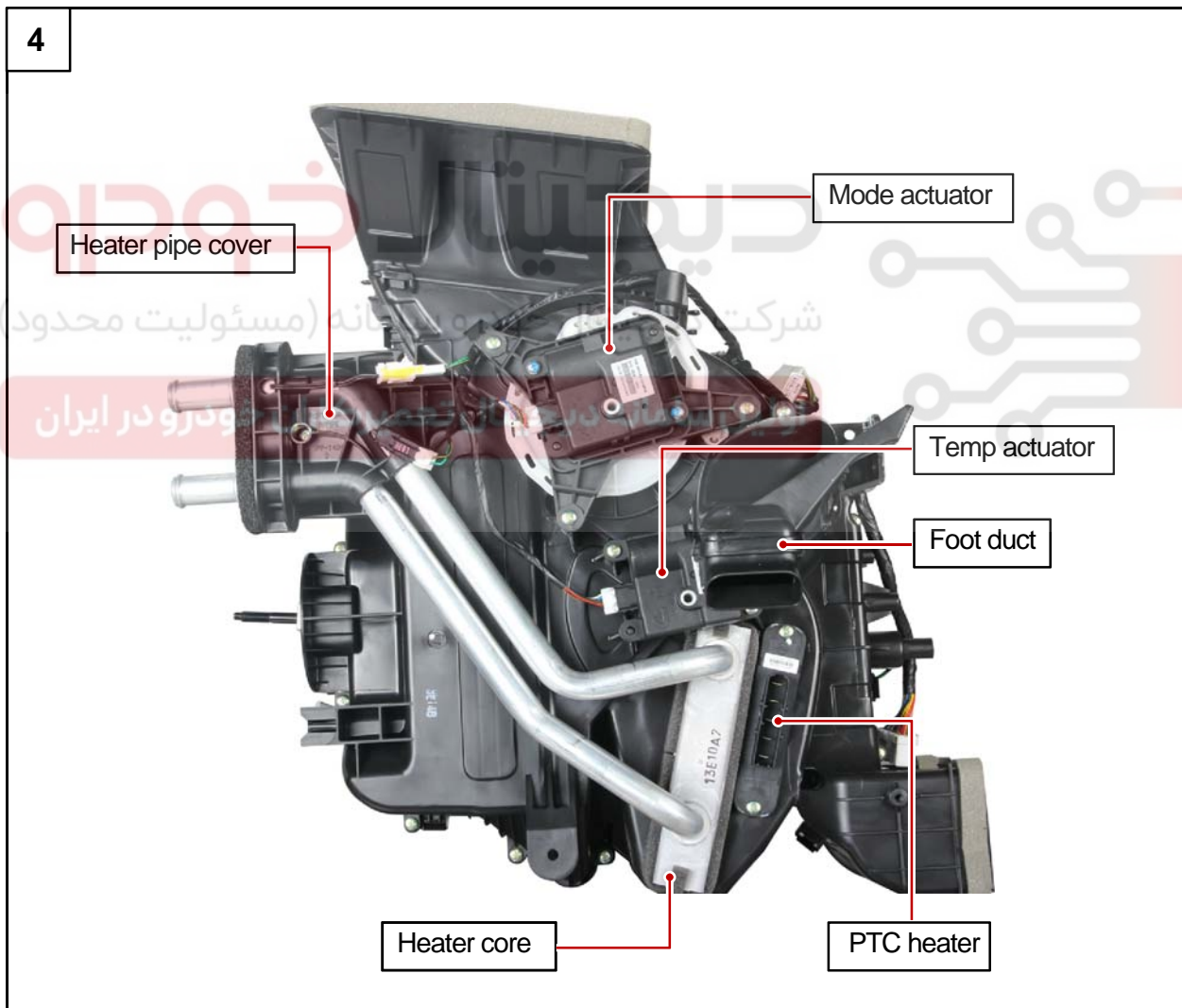

Modification basis	
Application basis	
Affected VIN	

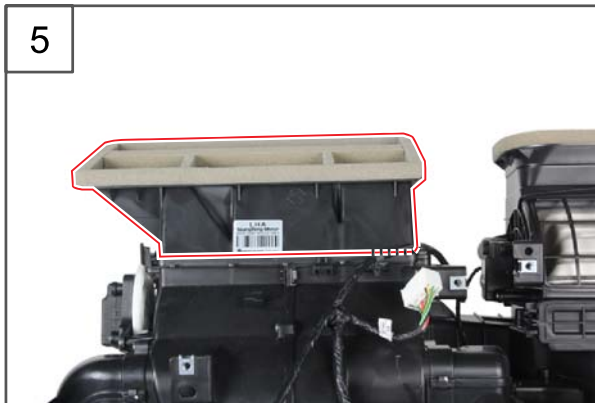

5. Remove the upper and lower parts of the heater and evaporator assembly while paying attention not to damage the clips (6 off).

Clips at upper part of heater and evaporator assembly case

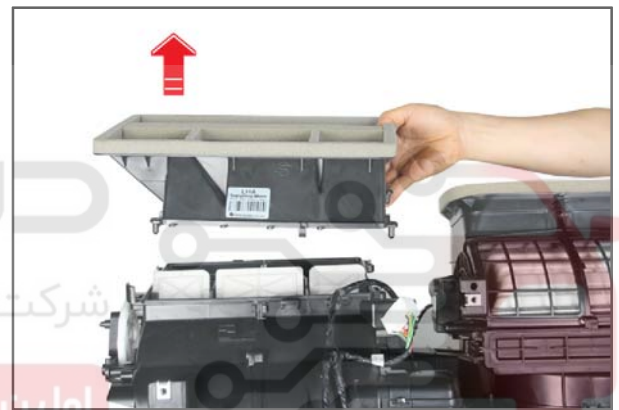
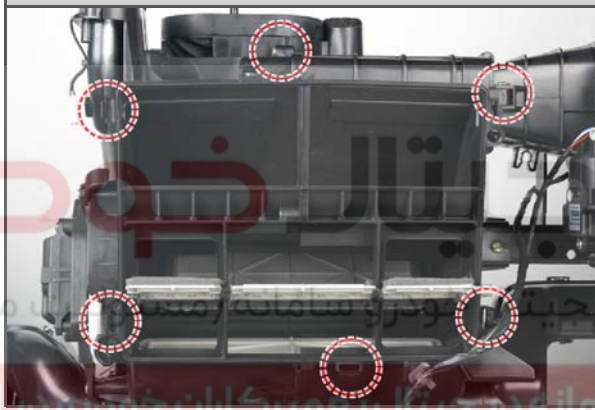

6. Unscrew the 14 mounting screws to remove the LH/RH cases of the heater and evaporator assembly.

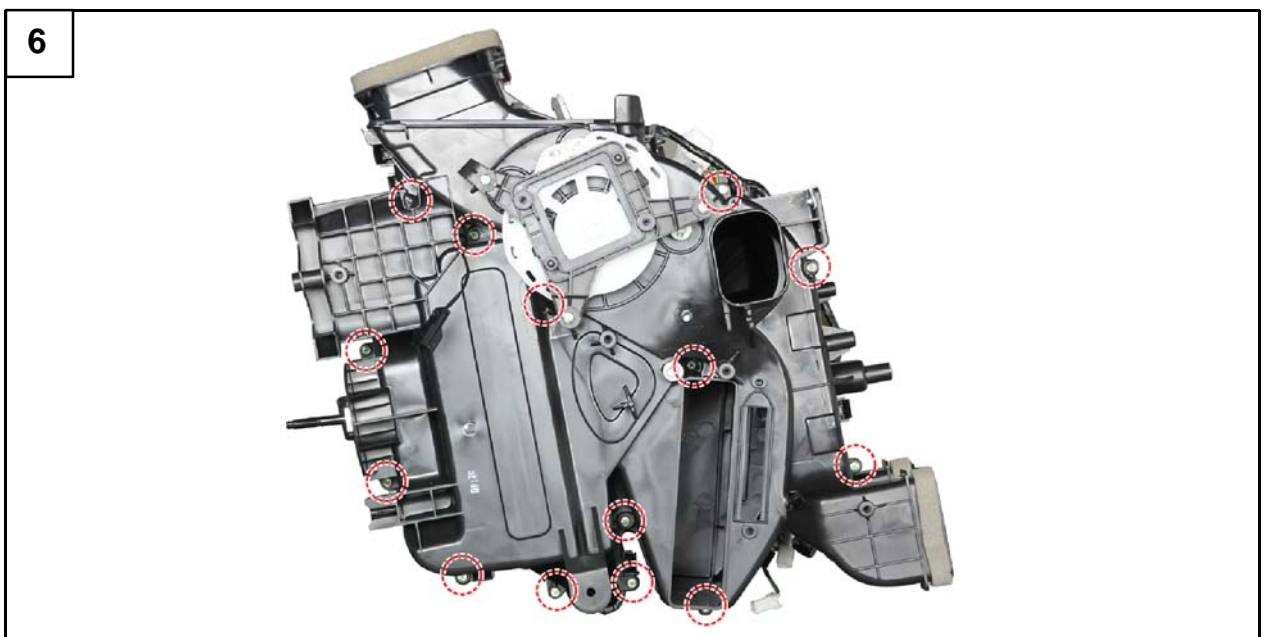

Modification basis	
Application basis	
Affected VIN	

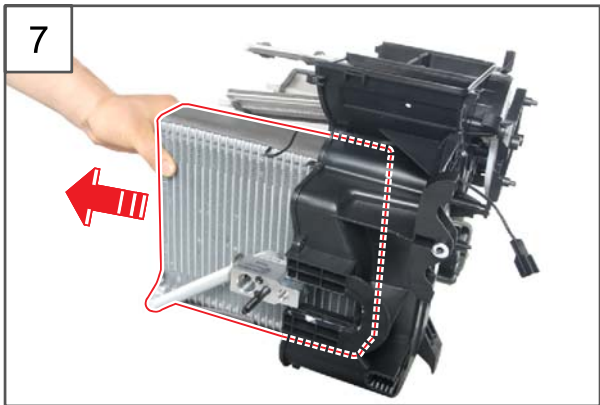

7. Remove the evaporator core from the left-hand case of the heat and evaporator assembly.

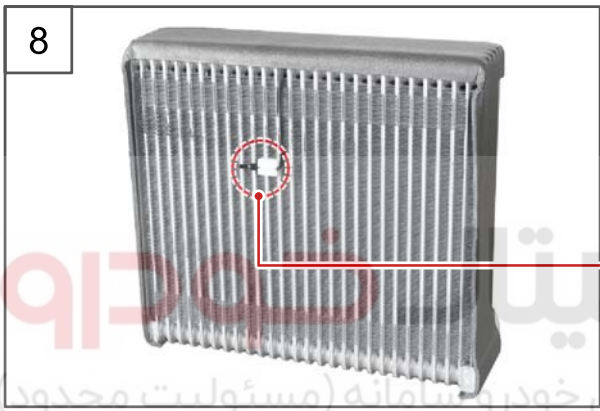

8. Remove the intake sensor from the evaporator core.



9. Install in the reverse order of removal.

Modification basis	
Application basis	
Affected VIN	

S.G.N. **6810-06 MOS MODULE**

Preceding work - Disconnect the negative battery cable.



- AIR CONDITIONING
- AIR BAG
- SEAT
- SUNROOF
- BODY INTERIOR
- BODY EXTERIOR
- BODY REPAIR

دیجیتال خودرو
 شرکت دیجیتال خودرو سامانه (مسئولیت محدود)
 اولین سیستم تعمیرات آنلاین خودرو در ایران



1. Remove the MOS module connector.

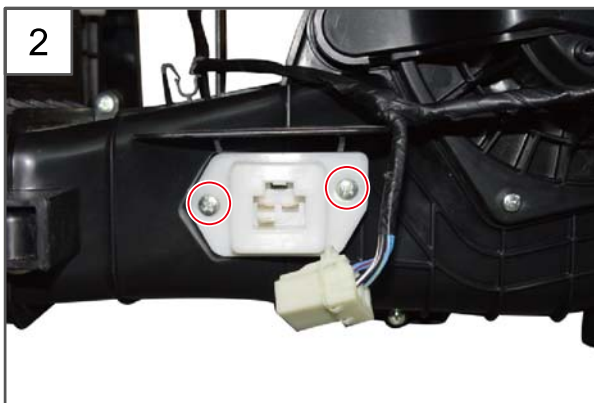

2. Unscrew the two MOS module mounting screws.

Modification basis	
Application basis	
Affected VIN	



3. Remove the MOS module.



4. Install in the reverse order of removal.

دیجیتال خودرو
شرکت دیجیتال خودرو سامانه (مسئولیت محدود)

اولین سامانه دیجیتال تعمیرکاران خودرو در ایران



Modification basis	
Application basis	
Affected VIN	

S.G.N.
6810-05 BLOWER MOTOR

Preceding work - Disconnect the negative battery cable.



AIR CONDITIONING
AIR BAG
SEAT
SUNROOF
BODY INTERIOR
BODY EXTERIOR
BODY REPAIR

دیجیتال خودرو
شرکت دیجیتال خودرو سامانه (مسئولیت محدود)
اولین سامانه دیجیتال خودرو در ایران



1. Disconnect the blower motor connector.

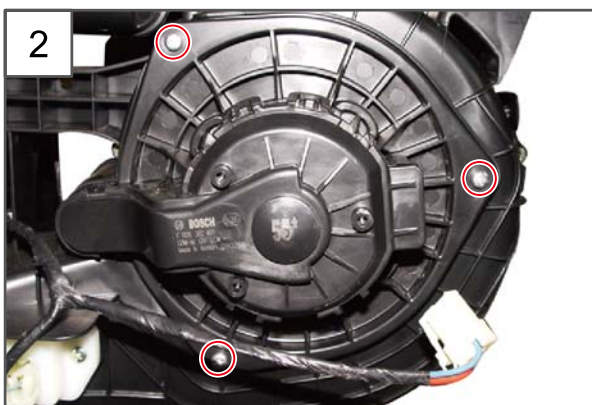

2. Unscrew the three blower motor mounting screws.

Modification basis	
Application basis	
Affected VIN	



3. Remove the blower motor.



4. Install in the reverse order of removal.

دیجیتال خودرو
شرکت دیجیتال خودرو سامانه (مسئولیت محدود)

اولین سامانه دیجیتال تعمیرکاران خودرو در ایران



Modification basis	
Application basis	
Affected VIN	

S.G.N. **6810-03 AIR CONDITIONER FILTER**

 **NOTE**

Change interval

- Replace at every 10,000 km of driving.
- If the vehicle is driven under severe conditions such as dusty road, unpaved road, and excessive A/C and heater operation, shorten the replacement interval.



1. Disengage the mountings (A) and (B) to remove the glove box.



Modification basis	
Application basis	
Affected VIN	

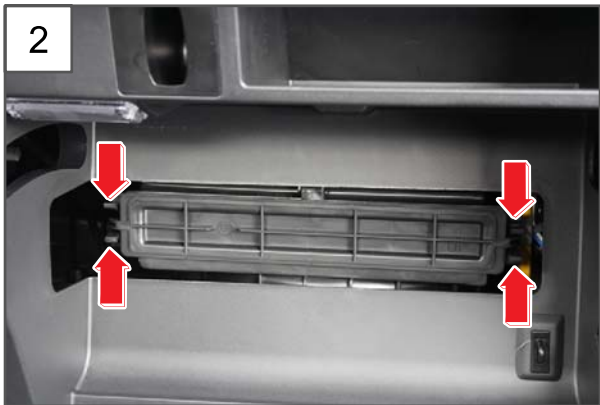

2. Remove the A/C filter cover while pressing the A/C filter cover handle up and down.



3. Remove the A/C filter from the A/C filter cover.



4. Install in the reverse order of removal.



NOTE

How to check

- Remove the A/C air filter to check the filter for contamination and clogging by foreign materials.
- Replace the filter as necessary even within the replacement interval.

Modification basis	
Application basis	
Affected VIN	

S.S.N. **8520-18** SUN LOAD SENSOR

Preceding work - Disconnect the negative battery cable.



- AIR CONDITIONING
- AIR BAG
- SEAT
- SUNROOF
- BODY INTERIOR
- BODY EXTERIOR
- BODY REPAIR

دیجیتال خودرو
 شرکت دیجیتال خودرو سامانه (مسئولیت محدود)
 اولین سامانه دیجیتال تعمیرکاران خودرو در ایران



1. Detach the sun load sensor using a hand remover.



2. Disconnect the connector and remove the sun load sensor.

3. Install in the reverse order of removal.

Modification basis	
Application basis	
Affected VIN	

S.G.N.
8520-14 AMBIENT TEMPERATURE SENSOR

Preceding work - Disconnect the negative battery cable.

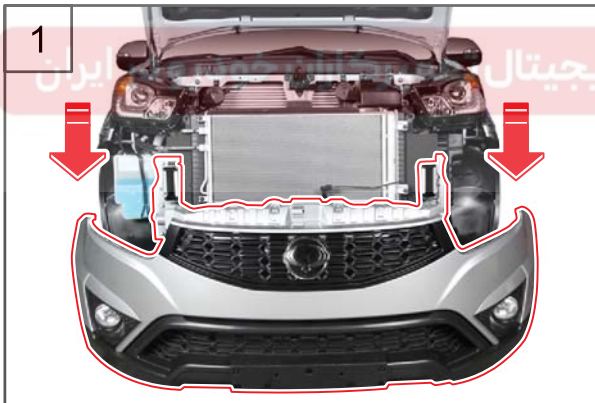

1. Remove the front bumper.

 **NOTE**

See "FRONT BUMPER" under "REMOVAL AND INSTALLATION" in "BODY EXTERIOR".

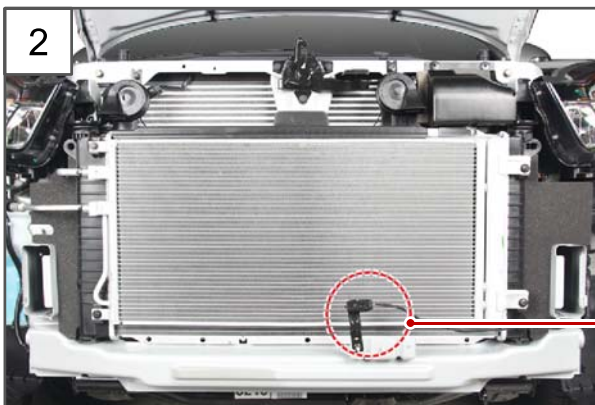

2. Disconnect the ambient temperature sensor connector.



Modification basis	
Application basis	
Affected VIN	



3. Remove the ambient temperature sensor from a fixed position.



4. Install in the reverse order of removal.

دیجیتال خودرو
شرکت دیجیتال خودرو سامانه (مسئولیت محدود)

اولین سامانه دیجیتال تعمیرکاران خودرو در ایران



AIR
CONDITIO
AIR BAG
SEAT
SUNROO
F
BODY
INTERIOR
BODY
EXTERIO
BODY
REPAIR

Modification basis	
Application basis	
Affected VIN	

S.G.N.
8520-15 PTC HEATER

Preceding work - Disconnect the negative battery cable.



شرکت دیجیتال خودرو (مسئولیت محدود)

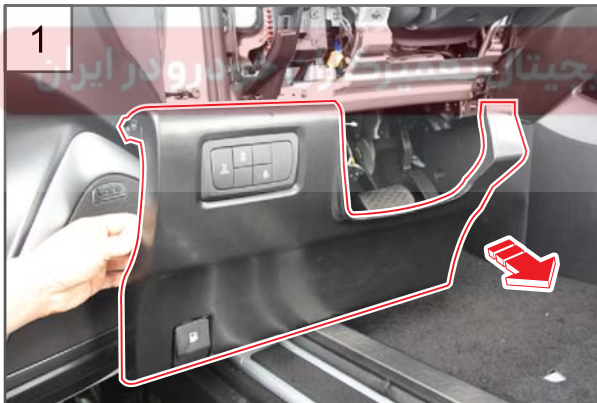

1. Remove the lower main panel.

NOTE

Refer to "LOWER MAIN PANEL" under "REMOVAL AND INSTALLATION" in "BODY INTERIOR" chapter.

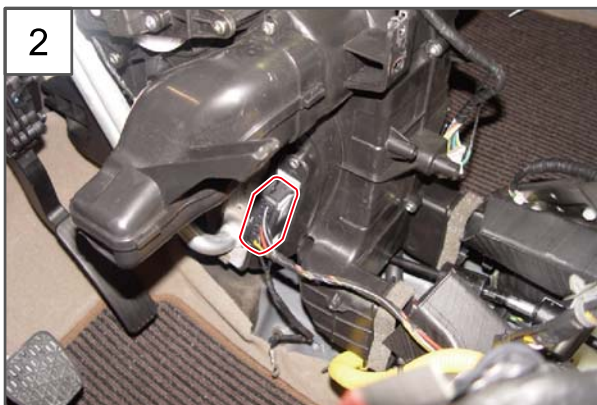

2. Disconnect the PTC heater connector.

Modification basis	
Application basis	
Affected VIN	



3. Unscrew the two mounting screws for the PTC heater.



4. Remove the PTC heater.



5. Install in the reverse order of removal.



Modification basis	
Application basis	
Affected VIN	

S.G.N. **6820-02** A/C COMPRESSOR

Preceding work

- Disconnect the negative battery cable.
- Drain the A/C refrigerant in a suitable container. Dispose the collected refrigerant as per local environmental guidelines.
- Remove the engine acoustic cover.
- Remove the under cover under the vehicle.

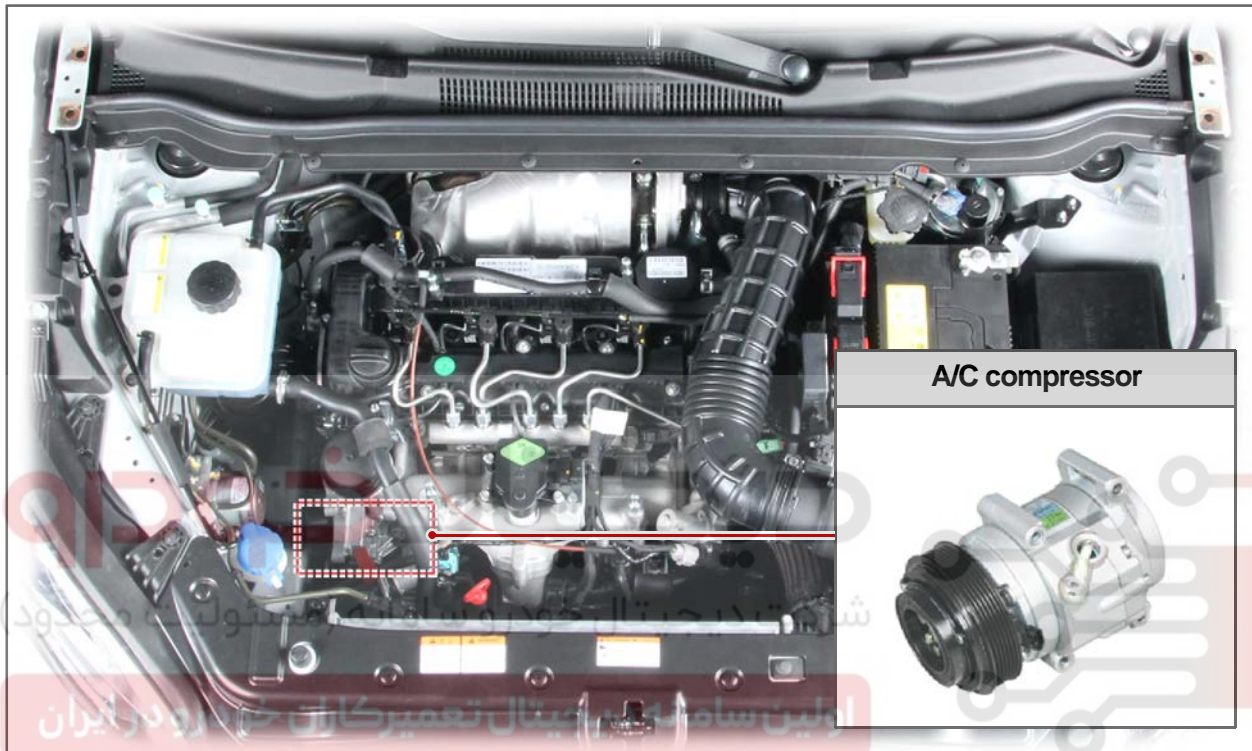

1. Turn the pivot damped tensioner bolt (A) anti-clockwise using the special tool to relieve the tension and remove the fan belt.

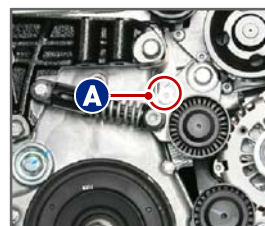

Special tool:
T9941 0010A

Modification basis	
Application basis	
Affected VIN	

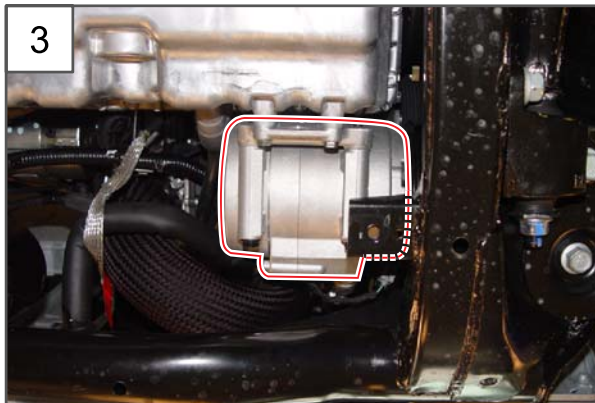

3. Unscrew the one mounting bolt (A, 12 mm) under the vehicle to disconnect the discharge and suction hose from the A/C compressor.

Tightening torque 11.8 to 16.7 Nm

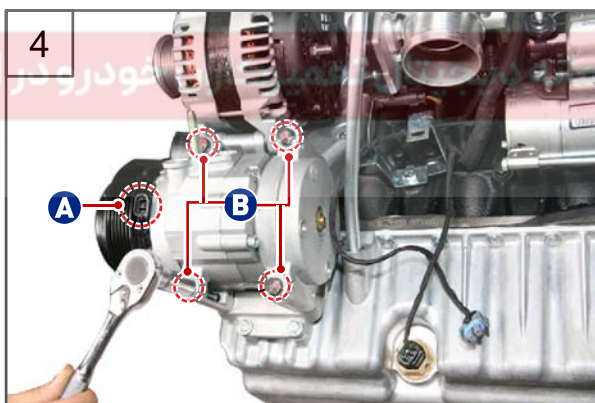

4. Disconnect the connector (A) and unscrew the one mounting bolt (B, 13 mm) to remove the A/C compressor.

Tightening torque 19.7 to 24.5 Nm



5. Install in the reverse order of removal.

Modification basis	
Application basis	
Affected VIN	

S.G.N.
6820-01 A/C CONDENSER

Preceding work

- Disconnect the negative battery cable.
- Drain the A/C refrigerant in a suitable container. Dispose the collected refrigerant as per local environmental guidelines.

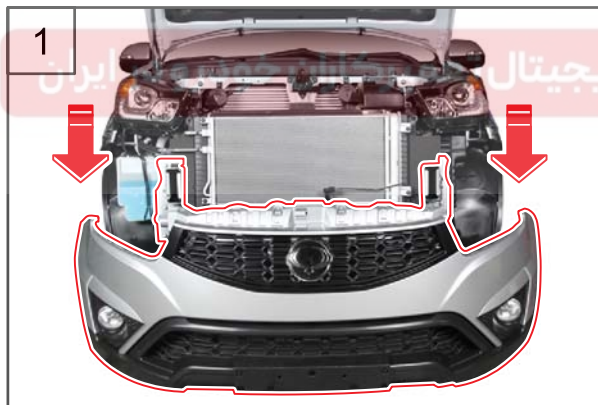
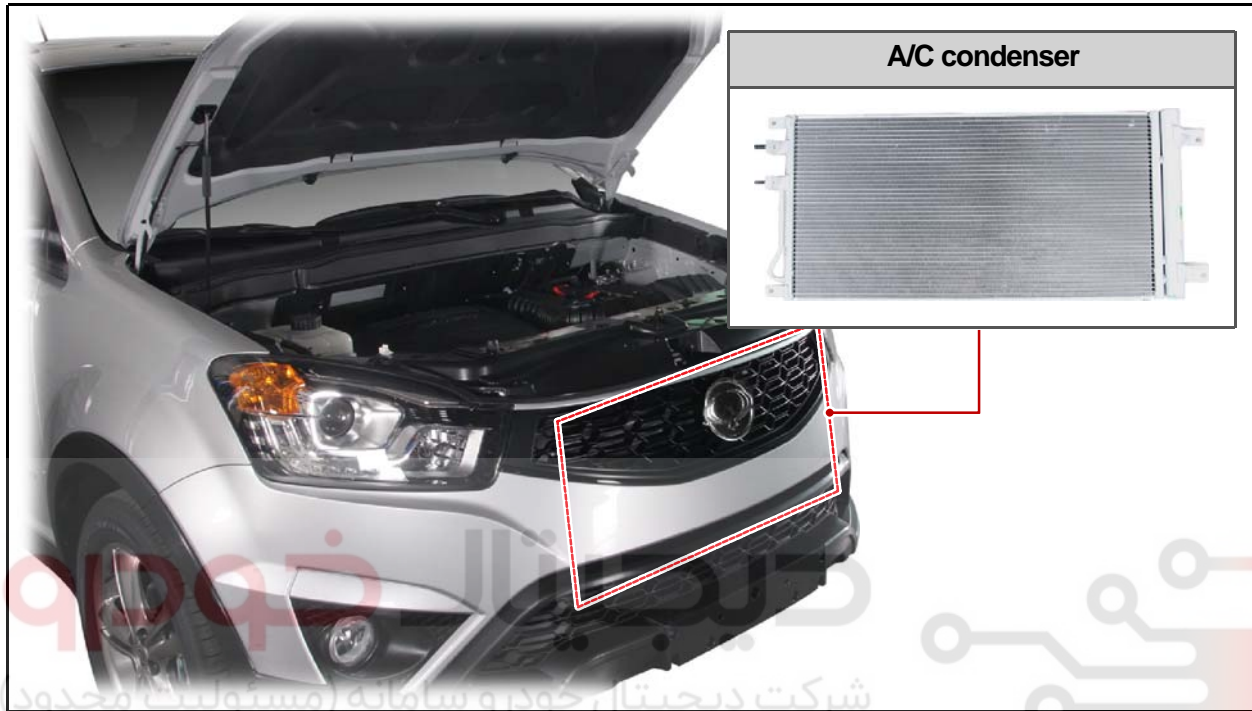

1. Remove the front bumper.

 **NOTE**

See "FRONT BUMPER" under "REMOVAL AND INSTALLATION" in "BODY EXTERIOR".

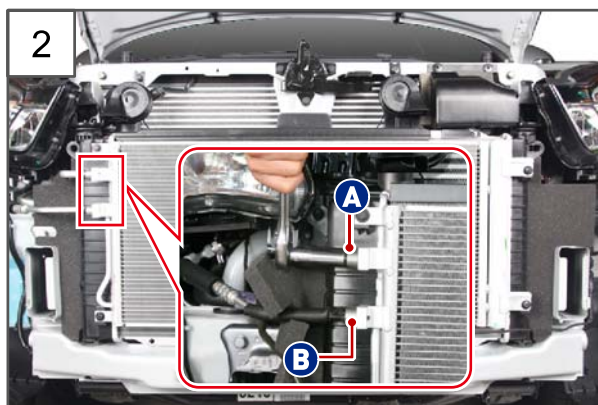

2. Unscrew the mounting nuts (A and B) and disconnect the A/C pipe from the A/C condenser.

- (A) One mounting nut (12 mm) on discharge and suction pipe
- (B) One mounting nut (10 mm) on liquid and suction pipe

Modification basis	
Application basis	
Affected VIN	



3. Unscrew the 4 mounting bolts (10 mm) on the A/C condenser.

Tightening torque 10 ± 1.0 Nm

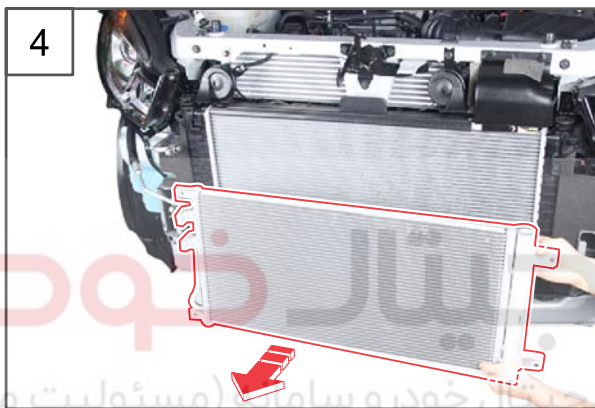

4. Remove the A/C condenser.



5. Install in the reverse order of removal.

- AIR CONDITIONING
- AIR BAG
- SEAT
- SUNROOF
- BODY INTERIOR
- BODY EXTERIOR
- BODY REPAIR

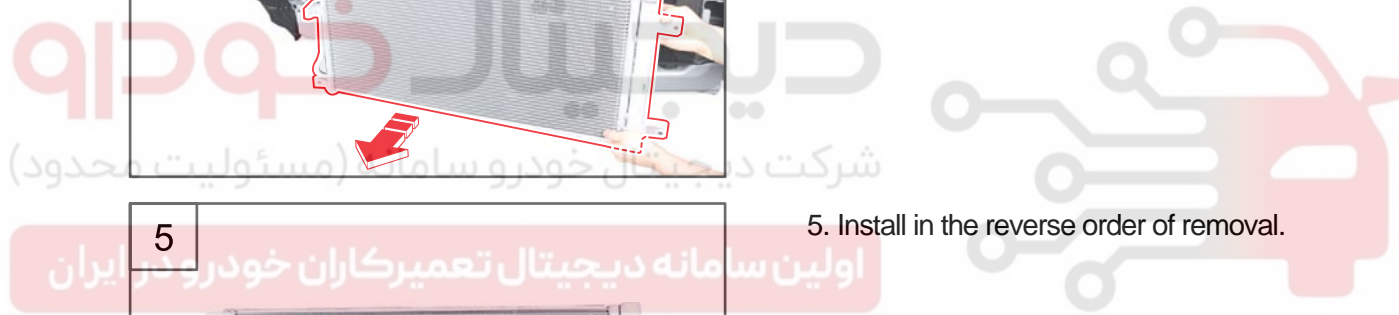

Modification basis	
Application basis	
Affected VIN	

Memo

دیجیتال خودرو

شرکت دیجیتال خودرو سامانه (مسئولیت محدود)

اولین سامانه دیجیتال تعمیرکاران خودرو در ایران

