

## TIRE AND WHEEL

<b>GENERAL INFORMATION</b>	<b>24-3</b>	<b>ON-VEHICLE SERVICE</b>	<b>24-8</b>
<b>Overview</b>	<b>24-3</b>	<b>Wheel</b>	<b>24-8</b>
Description	24-3	Removal	24-8
Precautions	24-4	Installation	24-8
Tire Identification	24-4	<b>Tire Replacement</b>	<b>24-9</b>
Specifications	24-5	Removal	24-9
Tool	24-5	<b>Wheel Balance</b>	<b>24-10</b>
<b>DIAGNOSIS &amp; TESTING</b>	<b>24-6</b>	Removal	24-10
<b>Diagnosis Content</b>	<b>24-6</b>	<b>Tire Rotation</b>	<b>24-11</b>
Problem Symptoms Table	24-6	Operation Step	24-11
Inspection	24-6		

# دیجیتال خودرو

شرکت دیجیتال خودرو سامانه (مسئولیت محدود)

اولین سامانه دیجیتال تعمیرکاران خودرو در ایران



# دیجیتال خودرو

شرکت دیجیتال خودرو سامانه (مسئولیت محدود)

اولین سامانه دیجیتال تعمیرکاران خودرو در ایران



# GENERAL INFORMATION

## Overview

### Description

#### Tire

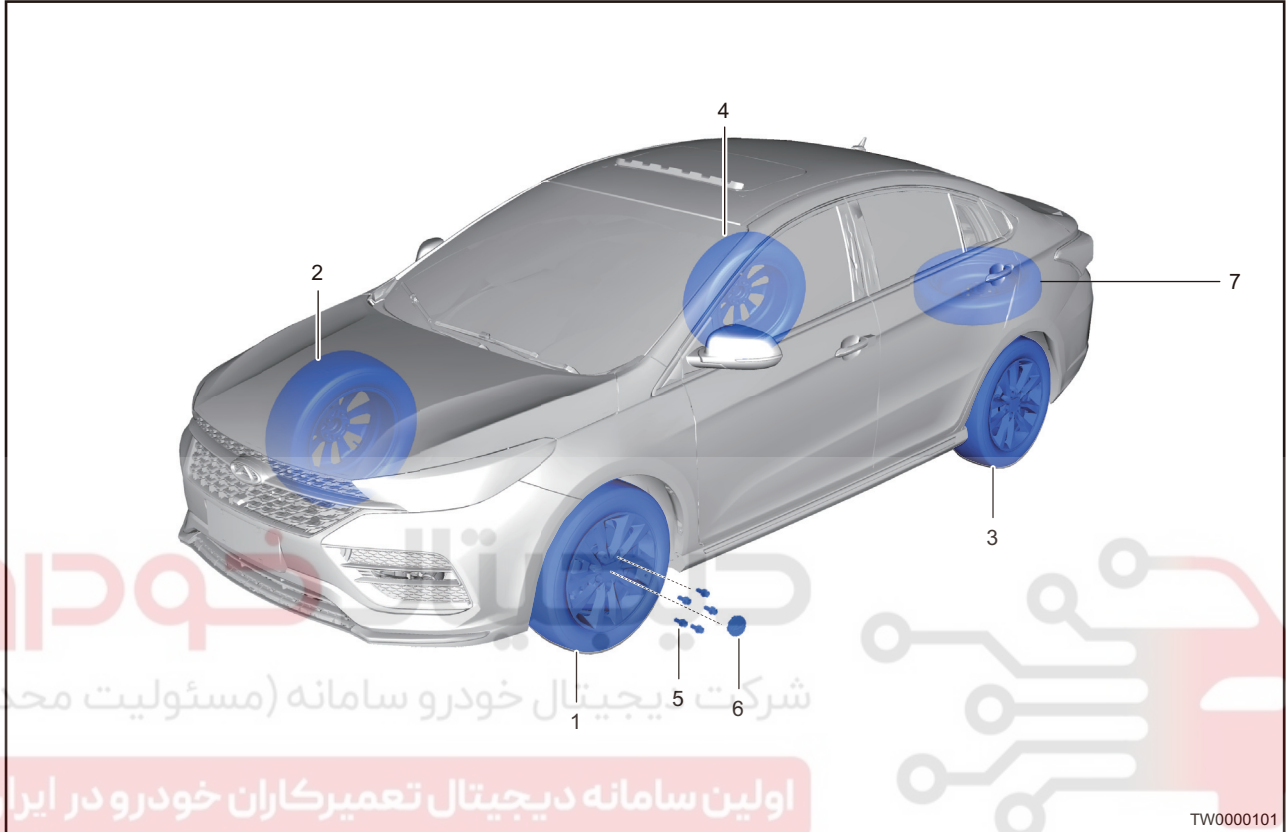

1 - Front Left Wheel	2 - Front Right Wheel
3 - Rear Left Wheel	4 - Rear Right Wheel
5 - Front Left Bolt	6 - Front Left Aluminum Rim Trim Cover
7 - Spare Tire Assembly	

## Precautions

1. Use tires only with the standard specification and type, because they have excellent reliability and skid resistance. Using a non-standard tire may lead to vehicle malfunction, which may cause an accident, resulting in serious injury or even death.
2. Contact surface between rim and tire should be cleaned before installing a new tire.
3. When installing wheel bolts, firstly, pre-tighten the bolts by hand, and then tighten them to the specified torque with a torque wrench.
4. Do not apply grease to the wheel bolts.
5. Some bad driving habits may shorten the tire life:
  - (a) Rapid acceleration
  - (b) Depressing brake pedal suddenly and firmly
  - (c) High-speed driving
  - (d) Turning at excessive speed
  - (e) Striking curbs or other obstacles
  - (f) Tire pressure is too High or too low when driving vehicle

## Tire Identification

1. Letter and number code of tire type, size, load index and speed level are stamped on the side wall of tire as shown in the illustration.

- 16-inch aluminum rim: 205/55 R16



- 17-inch full-coated aluminum rim: 205/50 R17 93V



- 17-inch glossy aluminum rim: 205/50 R17 93V



## Specifications

### Torque Specifications

Description	Torque (N·m)
Wheel Mounting Bolt	110 ± 10

### Tire Type

Description	Type
Tire Type	205/55 R16, 205/50 R17

### Rim Type

Description	Type
Rim Type	16 × 6v1/2J, 17 × 6 1/2J

### Tire Pressure Specifications (Before Four Wheel Alignment)

Description	Tire Pressure (kPa)
Front Tire	220 ± 10
Rear Tire	220 ± 10
T-type Spare Tire (Rated Inflation Pressure)	420 ± 20

## Tool

### General Tool

<p>دیجیتال خودرو</p> <p>شرکت دیجیتال خودرو (مسئولیت محدود)</p> <p>اولین سامانه دیجیتال تعمیرکاران خودرو در ایران</p> <p>Tire Depth Gauge</p>	 <p>094</p>
----------------------------------------------------------------------------------------------------------------------------------------------	-------------------------------------------------------------------------------------------------

## DIAGNOSIS & TESTING

### Diagnosis Content

#### Problem Symptoms Table

##### Hint:

Use symptoms table below to determine cause of problem. Check each suspected area in sequence. Repair or adjust faulty components, or replace as necessary.

Symptom	Suspected Area
Wear on one side of tire	Wheel alignment (incorrect)
Wear on both sides of tire	Tire pressure (insufficient)
Tire center wear	Tire pressure (excessive)
Serrated wear	Wheel alignment (incorrect)
Severe wear on some area of tire	Braking (too hard)
Scratches on side wall of tire	Sharp objects on road (scratched)
Excessive tire noise	Tire pressure (incorrect)
	Tire (worn)

### Inspection

#### Warning/Caution/Hint

##### Caution:

- Be sure to refer to the instruction when installing non-standard tires and rims.
  - Use tires with standard specification and type.
1. Check if tires are scratched or damaged as shown in the illustration.
  2. Check if rims are scratched or damaged as shown in the illustration.



TW0003002

3. Check if tires are worn abnormally as shown in the illustration.

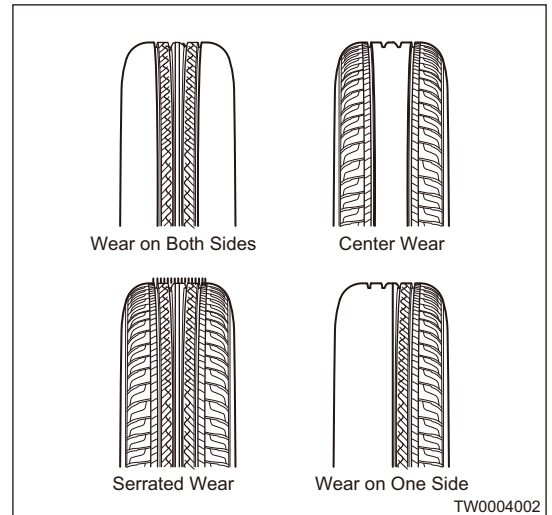

4. Measure the tread pattern depth with a tire depth gauge. When the depth is less than 1.6 mm, the tire should be replaced.

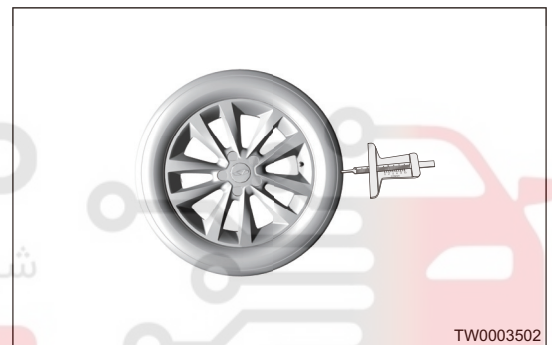

5. Check the tread wear indicators (arrow). When tires are worn to the indicating mark, replace them.

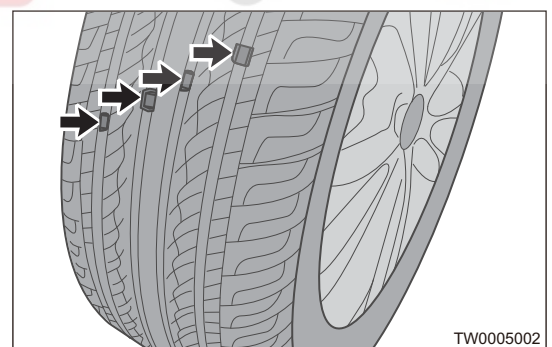

6. Use tire pressure gauge to check if pressures of all tires (including spare tire) are normal. Inflate tires to specified tire pressure as necessary.
7. Check air valve for leakage.

## ON-VEHICLE SERVICE

### Wheel

#### Removal

1. Remove the wheel.
  - (a) Stop vehicle at a level surface and apply parking brake.
  - (b) Using a tire wrench, loosen the wheel mounting bolts.
  - (c) Firmly support and raise the vehicle to a proper height.
  - (d) Using a tire wrench, remove 5 wheel mounting bolts.



- (e) Remove the wheel.
  - When removing and installing the wheel with tire pressure sensor, the tire pressure monitoring section must be strictly referred to.

#### Installation

1. Install the wheel.
  - (a) Anti-corrosion and anti-rust treatment is conducted on the contact surface between wheel and brake disc.
  - (b) Install the wheel and pre-tighten the wheel mounting bolts by hand.
  - (c) Using a torque wrench, tighten the wheel mounting bolts evenly to the specified torque in the order shown in the illustration.

#### Tightening torque

110 ± 10 N·m

#### Caution:

- DO NOT attempt to repair wheels by striking, heating or welding.
- Replace wheel mounting bolts with special wheel mounting bolts, rather than those with different specifications or inferior quality.
- Be careful not to damage coating on wheel.
- To avoid damage to tire or over/under tightening wheel mounting bolts, never use an impact wrench.
- DO NOT apply grease to wheel mounting bolts.

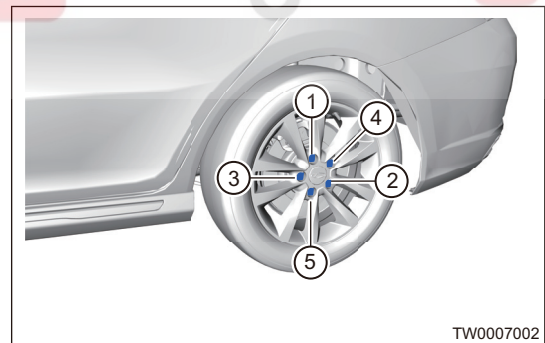



## Tire Replacement

### Removal

#### Warning/Caution/Hint

#### Warning:

- Speed level of new replaced tire must meet the specified values for safe operation; otherwise the tire may blow out.
1. Remove the wheel (See page 24-8).
  2. Use a tire remover to remove tires according to the instructions.

#### Caution:

- When removing and installing the tire with tire pressure sensor, the tire pressure monitoring section must be strictly referred to.
- Before installing air valve, check if air valve hole of wheel is smooth without any burrs, and apply glycerin to air valve rubber surface or soak air valve into glycerin fluid, and then pull or press the locating ring of air valve by force to pass it through the air valve hole and install it into place (it is possible to use soapy water instead of glycerin).
- The four driving tires mounted on the same vehicle must be from the same manufacturer and are not allowed to be mixed.
- Before assembling the tire, apply glycerin or soapy water to the rim area of tire.
- When installing wheel assembly with TPMS, align dynamic balance testing mark (light point) on tire with valve core (TPMS) position on rim.
- When there is "dark point" mark on rim, align the dynamic balance testing mark on tire with "dark point" mark on rim.
- When there is no "dark point" mark on rim, align the dynamic balance testing mark on tire with the air cock.

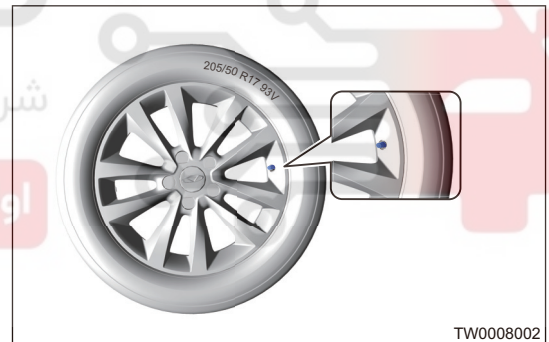

TW0008002

3. Adjust tire pressure to specified value.

#### Caution:

- Before performing four wheel alignment work, check the four tires pressure and adjust the pressure: Front wheel:  $(300 \pm 20)$  kPa, rear wheel:  $(300 \pm 20)$  kPa.
- The rated inflation pressure of T-type spare tire assembly:  $(420 \pm 20)$  kPa, isolated from the four wheels on the vehicle
- Please replace the tires only with standard specification and type.

4. Check contact surface among air valve, tire and rim for leakage.
5. Using a dynamic balancer, adjust the wheel balance.
6. Install the wheel.

#### Tightening torque

$110 \pm 10$  N·m

#### Caution:

- Avoid scratching tires and rims when removing tires.
- Contact surface between tire and rim should be cleaned when installing tires.

## Wheel Balance

### Removal

#### Warning/Caution/Hint

##### Caution:

- Dynamic balancer must be calibrated before adjusting wheel balance.
  - Remove impurities inside tread pattern and original balance blocks to ensure wheel balance.
1. Remove the wheel (See page 24-8).
  2. Adjust tire pressure to specified value.
  3. Install wheel with balance block removed to balancer. Install the balance shaft with mounting surface of wheel facing inward, choose a suitable taper body, and firmly lock the wheels using a locking device (align the taper body with center hole, otherwise data may be incorrect).
  4. Turn on the power source of balancer, and input parameters such as the measured distance from rim to balancer, rim width and rim diameter.
  5. Put down the wheel protector, and proceed to balance test procedure automatically (start button should be pushed for some balancers). When measurement is completed, the unbalanced weight for both sides of tire will be displayed on the balancer automatically, and the wheel brakes automatically until it stops. Do not open the protector before stopping. Failure to do this may lead to an accident.
  6. According to the measurement result, corresponding balance blocks should be installed on the outside (1) and inside (2) of rim edge as shown in the illustration.

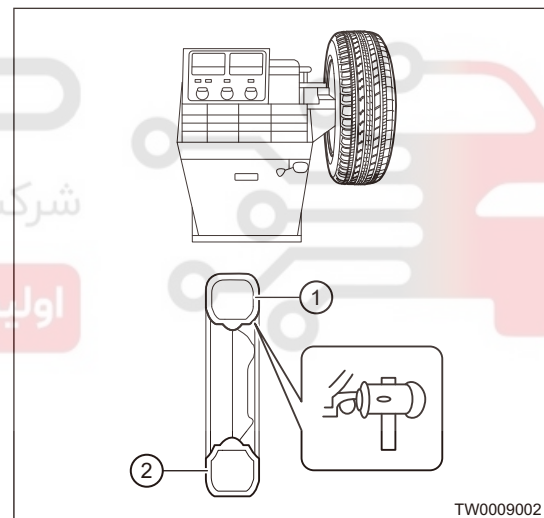

7. Perform test again after assembly is completed, until the balancer displays 0.
8. After dynamic balance is completed, remove the wheel.

##### Caution:

- When installing balance blocks, wheel dynamic balance requirements for vehicles with a maximum design speed greater than 100 km/h, allowing residual dynamic unbalanced mass: clamp type balance block side is 8 g or less, and paste type balance block side is 10 g or less.
- Clamp type balance block installation: Either side of each wheel is permitted to use only one clamp type balance block at most. DO NOT tap balance blocks forcibly during installation. If so, the balance block needs to be replaced in time. The replaced balance block is not allowed to be used again.
- Paste type balance block installation: Before pasting, wipe the adhesive part of aluminum rim with alcohol cotton to ensure that there is no oil, dust, etc. Tear off the plastic tape behind the adhesive balance block, and align it with step reference surface of pasting position, and apply force evenly with both hands. When the ambient temperature is lower than 25°C, the paste type balance block should be heated and insulated to ensure that the temperature is between 25°C and 38°C when assembling.
- The T-type spare tire does not require dynamic balance test and the installation of balance block.

## Tire Rotation

### Operation Step

#### Description

Front and rear tires operate at different loads and perform different steering, driving and braking functions. For these reasons, different wear rate is formed, causing irregular wear patterns. These effects can be reduced by rotating tires at regular time.

Advantages of tire rotation:

- Improving tread life
- Maintaining traction levels
- Maintaining a smooth and quiet driveability

#### Caution:

- Chery recommends you rotate your tires every 10000 km. However, the best suitable time for tire rotation differs depending on driver's driving habits and road conditions.

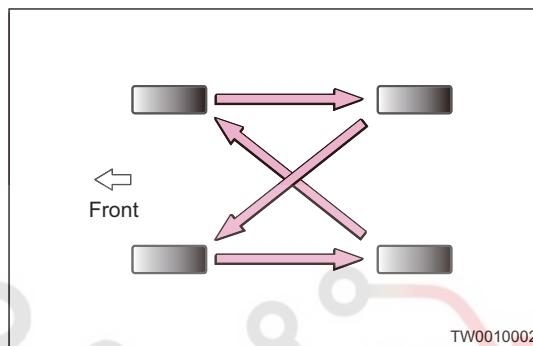

#### Rotation Method

Perform tire rotation as shown in the illustration.

شرکت دیجیتال خودرو (مسئولیت محدود)

اولین سامانه دیجیتال تعمیرکاران خودرو در ایران

# دیجیتال خودرو

شرکت دیجیتال خودرو سامانه (مسئولیت محدود)

اولین سامانه دیجیتال تعمیرکاران خودرو در ایران

