

SECTION **FL**

FUEL SYSTEM

CONTENTS

PRECAUTION	2	FUEL LEVEL SENSOR UNIT, FUEL FILTER AND FUEL PUMP ASSEMBLY	5	A
PRECAUTIONS	2	Exploded View	5	FL
General Precautions	2	Removal and Installation	6	C
PREPARATION	3	Disassembly and Assembly	10	D
PREPARATION	3	Inspection	10	E
Special Service Tool	3	FUEL TANK	12	F
Commercial Service Tool	3	Exploded View	12	G
ON-VEHICLE MAINTENANCE	4	Removal and Installation	12	H
FUEL SYSTEM	4	Inspection	13	I
Inspection	4	SERVICE DATA AND SPECIFICATIONS (SDS)	15	J
Quick Connector	4	SERVICE DATA AND SPECIFICATIONS (SDS)	15	K
ON-VEHICLE REPAIR	5	Fuel Tank	15	L
				M
				N
				O
				P

PRECAUTIONS

< PRECAUTION >

PRECAUTION

PRECAUTIONS

General Precautions

INFOID:000000006187253

WARNING:

When replacing fuel line parts, be sure to observe the following.

- Put a "CAUTION: FLAMMABLE" sign in the workshop.
- Be sure to work in a well ventilated area and furnish workshop with a CO₂ fire extinguisher.
- Never smoke while servicing fuel system. Keep open flames and sparks away from the work area.

CAUTION:

- Use gasoline required by the regulations for octane number. Refer to GI-29, "Fuel".
- Before removing fuel line parts, perform out the following procedures:
- Put drained fuel in an explosion-proof container and put the lid on securely. Keep the container in safe area.
- Release fuel pressure from the fuel lines. Refer to EC-418, "Inspection" (TYPE 1) or EC-783, "Inspection" (TYPE 2).
- Disconnect the battery cable from the negative terminal.
- Always replace O-ring and clamps with new ones.
- Never kink or twist tubes when they are being installed.
- Never tighten hose clamps excessively to avoid damaging hoses.
- After installing tubes, check there is no fuel leakage at connections in the following steps.
- Apply fuel pressure to fuel lines with turning ignition switch "ON" (with engine stopped). Then check for fuel leakage at connections.
- Start engine and rev it up and check for fuel leakage at connections.
- Use only a genuine NISSAN fuel filler cap as a replacement. If an incorrect fuel filler cap is used, the "MIL" may come on.
- For servicing "Evaporative Emission System" parts, refer to EC-420, "Inspection" (TYPE 1) or EC-785, "Inspection" (TYPE 2).

اولین سامانه دیجیتال تعمیرکاران خودرو در ایران

PREPARATION

< PREPARATION >

PREPARATION

PREPARATION

Special Service Tool

INFOID:000000006187254

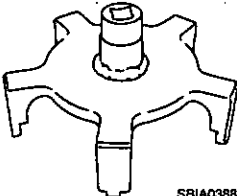
Tool number Tool name	Description
KV10118300 Fuel tank lock ring wrench <div style="text-align: center;">  <p>SBIA0388E</p> </div>	Removing and installing fuel tank retainer

Commercial Service Tool

INFOID:000000006187255

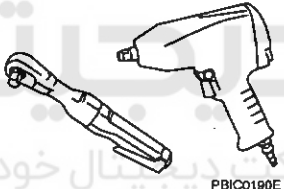
Tool name	Description
Power tool <div style="text-align: center;">  <p>PBIC0190E</p> </div>	Loosening nuts and bolts

دیجیتال خودرو
 شرکت دیجیتال خودرو سامانه (مسئولیت محدود)

اولین سامانه دیجیتال تعمیرکاران خودرو در ایران

FUEL SYSTEM

< ON-VEHICLE MAINTENANCE >

ON-VEHICLE MAINTENANCE

FUEL SYSTEM

Inspection

INFOID:000000006187256

Inspect fuel lines, fuel filler cap, and fuel tank for improper attachment, leakage, cracks, damage, loose connections, chafing or deterioration.

- A : Engine
- B : Fuel line
- C : Fuel tank

If necessary, repair or replace damaged parts.

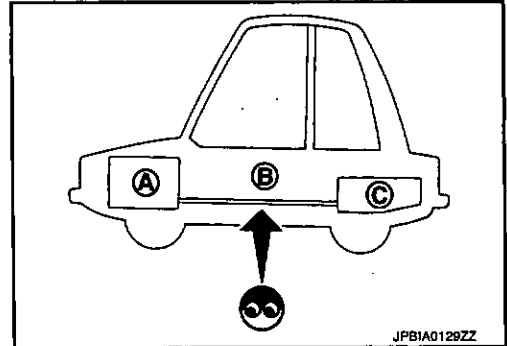

Quick Connector

INFOID:000000006187257

CAUTION:

- After connecting fuel tube quick connectors, check quick connectors are secure.

- 1 : Quick connector
- 2 : Retainer
- A : Hard tube (or the equivalent)
- B : Connection (cross-section)
- C : Resin tube
- D : To under floor fuel line
- E : To fuel tank
- F : Tab
- G : Disconnection

- Ensure that connector and resin tube never contact any adjacent parts.

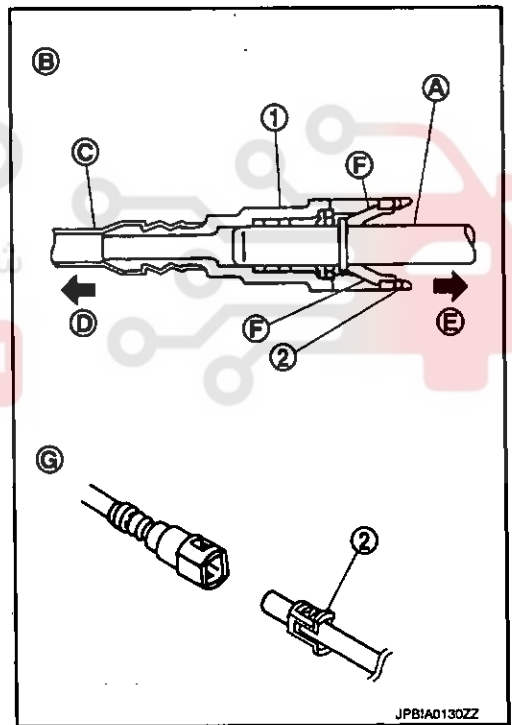

FUEL LEVEL SENSOR UNIT, FUEL FILTER AND FUEL PUMP ASSEMBLY

< ON-VEHICLE REPAIR >

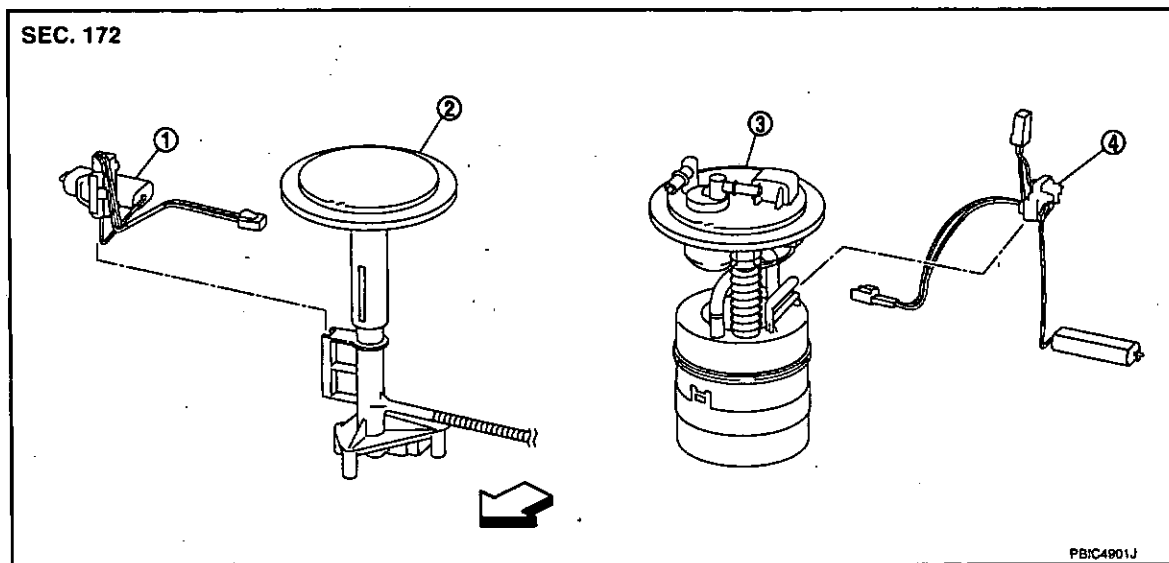

- 1. Sub fuel level sensor unit
 - 2. Sub fuel level sensor unit base
 - 3. Fuel filter and fuel pump assembly
 - 4. Fuel level sensor unit
- ← : Vehicle front

Removal and Installation

INFOID:0000000006187259

WARNING:

Read "General Precautions" when working on the fuel system. Refer to FL-2, "General Precautions".

REMOVAL

1. Check fuel level on fuel gauge. If fuel gauge indicates more than the level as shown in the figure (full or almost full), drain fuel from fuel tank until fuel gauge indicates level as shown in the figure or below.

NOTE:

Because fuel will be spilled when removing main and sub fuel level sensor units for the top of the fuel is above the main and sub fuel level sensor units installation surface.

• As a guide, fuel level becomes the position as shown in the figure or below when approximately 20 ℓ (4-3/8 Imp gal) of fuel are drained from fuel tank.

• In a case that fuel pump does not operate, perform the following procedure.

- a. Insert hose of less than 25 mm (0.98 in) in diameter into fuel filler tube through fuel filler opening to draw fuel from fuel filler tube.
 - b. Disconnect fuel filler hose from fuel filler tube. Refer to FL-12, "Exploded View".
 - c. Insert hose into fuel tank through fuel filler hose to draw fuel from fuel tank.
2. Release the fuel pressure from the fuel lines. Refer to EC-418, "Inspection" (TYPE 1) or EC-783, "Inspection" (TYPE 2).
 3. Open fuel filler lid.
 4. Open filler cap and release the pressure inside fuel tank.
 5. Remove rear seat cushion and reclining device assembly. Refer to SE-109, "Exploded View".

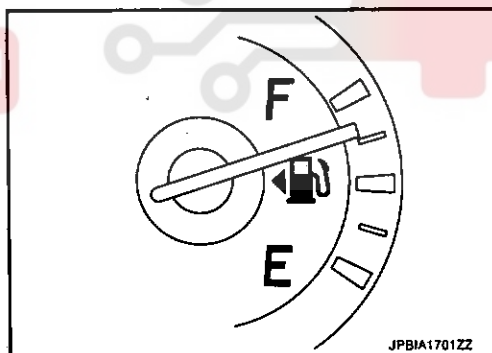

FUEL LEVEL SENSOR UNIT, FUEL FILTER AND FUEL PUMP ASSEMBLY

< ON-VEHICLE REPAIR >

6. Peel off floor carpet, then remove inspection hole cover units by turning clips clockwise by 90 degrees.

Left side : Main fuel level sensor unit, fuel filter and fuel pump assembly

Right side : Sub fuel level sensor unit

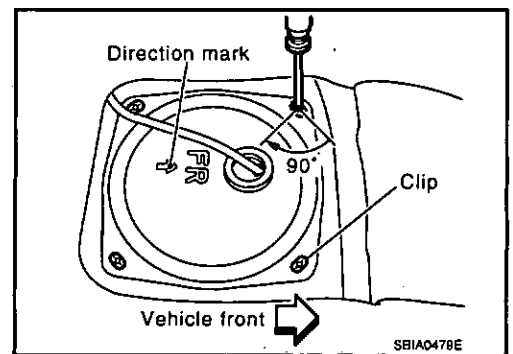

7. Disconnect harness connector, fuel feed tube and EVAP hose.

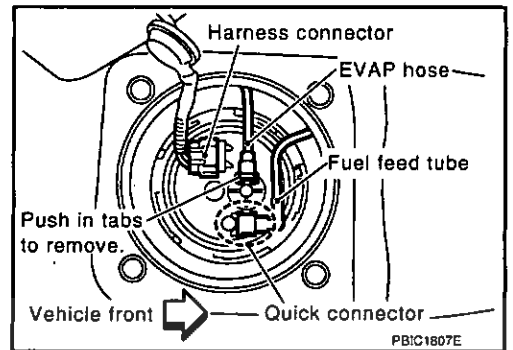

Disconnect quick connector as follows:

- Hold the sides of connector, push in tabs (B) and pull out fuel feed tube.

A : Pull

- If quick connector sticks to tube of main fuel level sensor unit, fuel filter and fuel pump assembly, push and pull quick connector several times until they start to move. Then disconnect them by pulling.

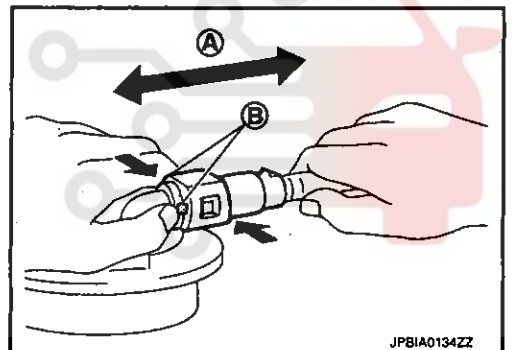

CAUTION:

A
FL
C
D
E
F
G
H
I
J
K
L
M
N
O
P

FUEL LEVEL SENSOR UNIT, FUEL FILTER AND FUEL PUMP ASSEMBLY

< ON-VEHICLE REPAIR >

- Quick connector (1) can be disconnected when the tabs (F) are completely depressed. Never twist it more than necessary.

- B : Connection (cross-section)
- D : To under floor fuel line
- E : To fuel tank
- G : Disconnection

- Never use any tools to disconnected quick connector.
- Keep resin tube (C) away from heat. Be especially careful when welding near the resin tube.
- Prevent acid liquid such as battery electrolyte, etc. from getting on resin tube.
- Never bend or twist resin tube during installation and disconnection.
- Never remove the remaining retainer (2) on hard tube (or the equivalent) (A) except when resin tube or retainer is replaced.
- When resin tube or hard tube (or the equivalent) is replaced, also replace retainer with new one.

Retainer color: Green

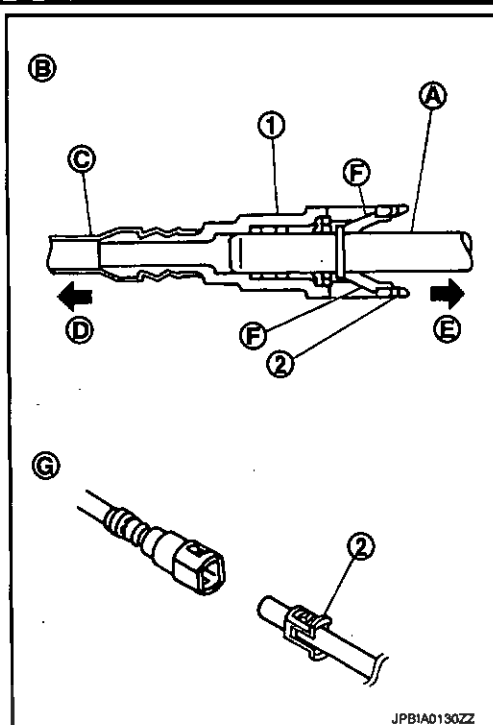

- To keep the connecting portion clean and to avoid damage and foreign materials, cover them completely with plastic bags (A) or something similar.

شرکت دیجیتال خودرو سامانه (مسئولیت محدود)

اولین سامانه دیجیتال تعمیرکاران خودرو در ایران

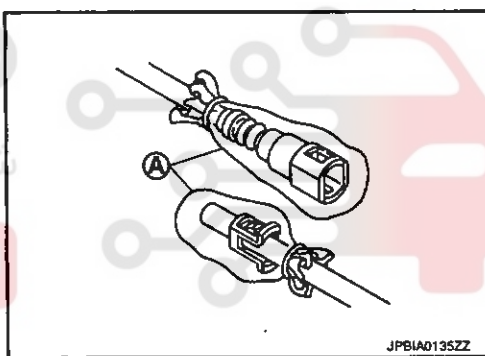

8. Remove retainer for main fuel level sensor unit, fuel filter and fuel pump assembly and sub fuel level sensor unit with fuel tank lock ring wrench [SST: KV10118300] by turning counterclockwise.

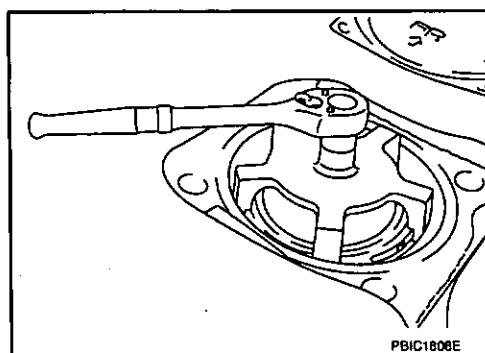

9. Remove main fuel level sensor unit, fuel filter and fuel pump assembly, and sub fuel level sensor unit.

FUEL LEVEL SENSOR UNIT, FUEL FILTER AND FUEL PUMP ASSEMBLY

< ON-VEHICLE REPAIR >

- Raise main fuel level sensor unit, fuel filter and fuel pump assembly, and disconnect fuel hose connector (push in tabs and pull out) and sub fuel level sensor unit harness connector.
- Raise and release sub fuel level sensor unit to remove.

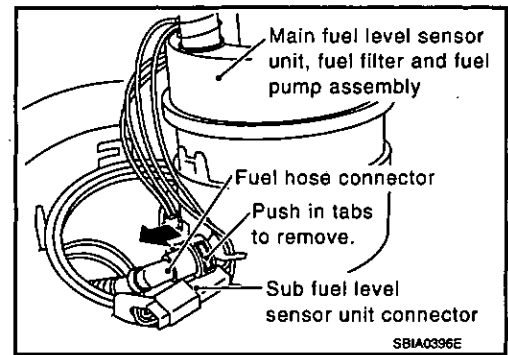

INSTALLATION

Note to the following, and install in the reverse order of removal.

Main Fuel Level Sensor Unit, Fuel Filter and Fuel Pump Assembly and Sub Fuel Level Sensor Unit

1. Install new seal packings to fuel tank without any twist.
2. Connect fuel hose connector (push in until it stops) and sub fuel level sensor unit harness connector.

NOTE:

When installing fuel hose connector insert them fully until a click sound of full stopper engagement is heard.

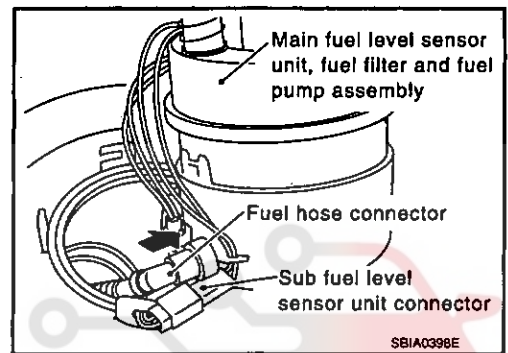

3. Align the direction mark on main fuel level sensor unit, fuel filter and fuel pump assembly and sub fuel level sensor unit with that on fuel tank as shown in the figure, and install them to fuel tank.

CAUTION:

- Never allow seal packings to drop.
- Never bend float arm during installing.

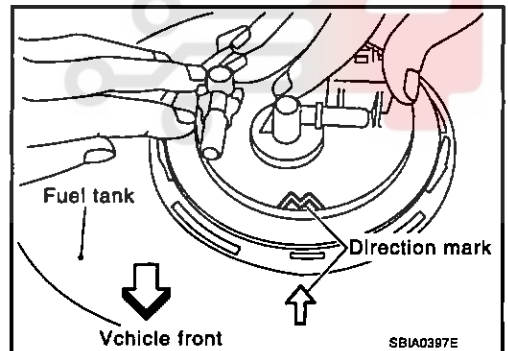

4. Install retainer for main fuel level sensor unit, fuel filter and fuel pump assembly and sub fuel level sensor unit with fuel tank lock ring wrench [SST: KV10118300] by turning clockwise.

CAUTION:

Install retainer horizontally.

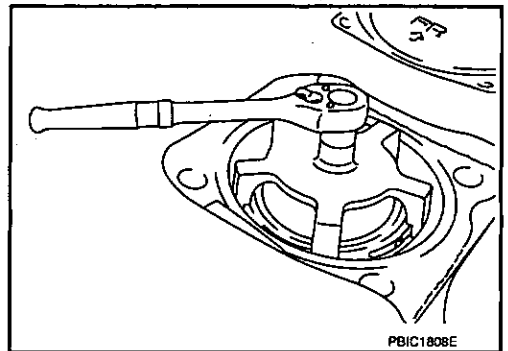

Quick Connector

Connect quick connector as follows:

1. Check the connection for damage or any foreign materials.
2. Align the connector with the tube, then insert the connector straight into the tube until a click sound is heard.
3. After connecting, check that the connection is secure by following method.

دیجیتال خودرو
اولین سامانه دیجیتال تعمیرکاران خودرو

A
FL
C
D
E
F
G
H
I
J
K
L
M
N
O
P

FUEL LEVEL SENSOR UNIT, FUEL FILTER AND FUEL PUMP ASSEMBLY

< ON-VEHICLE REPAIR >

- Pull the tube and the connector to check they are securely connected.

A : Pull

- Visually confirm that the two retainer tabs are connected to the connector.

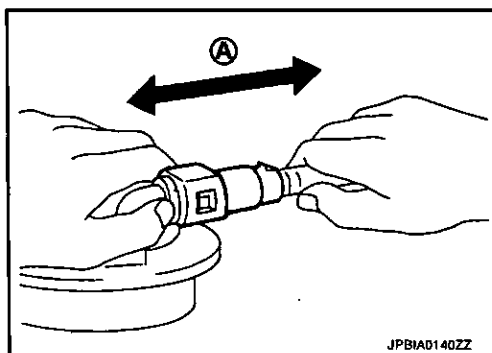

JPBIAD140ZZ

INFOID:000000006187260

Disassembly and Assembly

DISASSEMBLY

Fuel Level Sensor Unit, Fuel Filter and Fuel Pump Assembly side

1. Disconnect harness connector.
2. Remove fuel level sensor unit according to the following procedure.
 - a. Push the pawl of fuel level sensor unit (1) mounting area with an L-shaped iron rod or an equivalent to unlock.
CAUTION:
Be careful not to damage it.
 - b. With the fuel level sensor unit unlocked, slide it in the direction shown by the arrow (←).

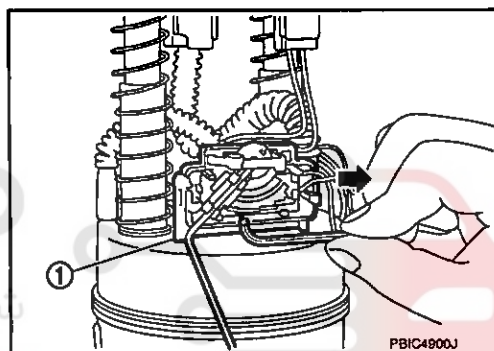

PBIC4900J

Sub Fuel Level Sensor Unit side

1. Remove sub fuel level sensor unit according to the following procedure.
 - a. Push the pawl of sub fuel level sensor unit (1) mounting area with an L-shaped iron rod or an equivalent to unlock.
CAUTION:
Be careful not to damage it.
 - b. With the sub fuel level sensor unit unlocked, slide it in the direction shown by the arrow (←).

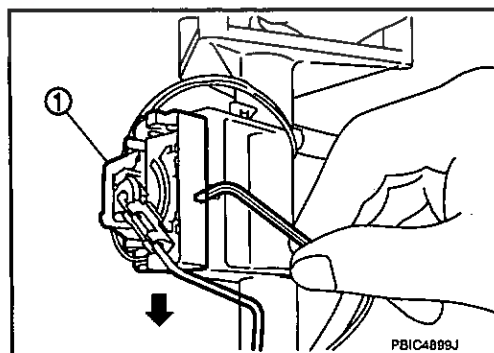

PBIC4895J

ASSEMBLY

Install fuel level sensor unit and sub fuel level sensor unit according to the following procedure.

- Insert fuel level sensor unit and sub fuel level sensor unit all the way to the end until a “click” touch and sound can be recognized.
- Pull fuel level sensor unit and sub fuel level sensor unit in the removal direction to ensure that they do not become detached.

Inspection

INFOID:000000006187261

INSPECTION AFTER INSTALLATION

Use the following procedure to check for fuel leakage.

1. Turn ignition switch “ON” (with engine stopped), then check connections for leakage by applying fuel pressure to fuel piping.

FUEL LEVEL SENSOR UNIT, FUEL FILTER AND FUEL PUMP ASSEMBLY

< ON-VEHICLE REPAIR >

2. Start engine and let it idle and check there are no fuel leakage at the fuel system connections.

A

FL

C

D

E

F

G

H

I

J

K

L

M

N

O

P

دیجیتال خودرو

شرکت دیجیتال خودرو سامانه (مسئولیت محدود)

اولین سامانه دیجیتال تعمیرکاران خودرو در ایران



FUEL TANK

< ON-VEHICLE REPAIR >

FUEL TANK

Exploded View

INFOID:000000006187262

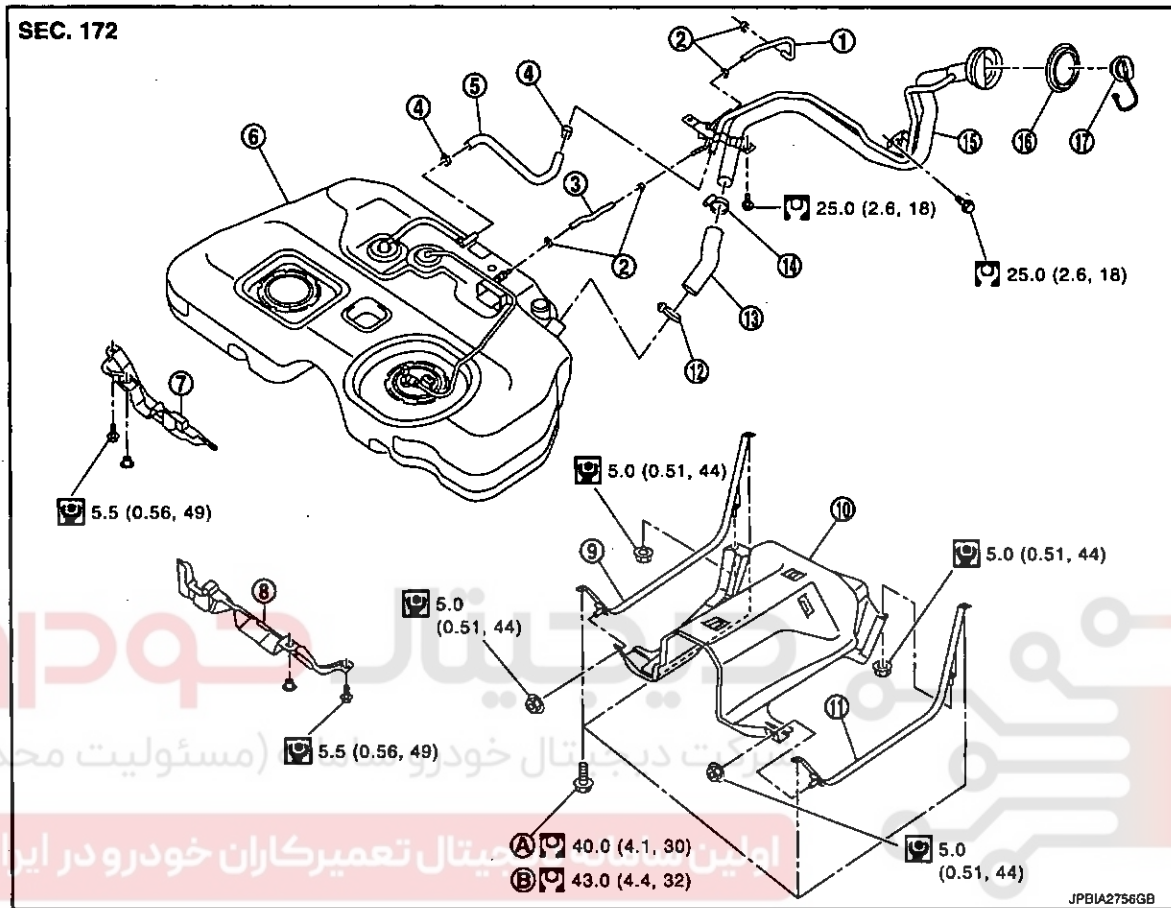

- | | | |
|-----------------------------|----------------------------------|---------------------------------|
| 1. EVAP hose | 2. Clamp | 3. EVAP hose |
| 4. Clamp | 5. Vent hose | 6. Fuel tank |
| 7. Fuel tank protector (RH) | 8. Fuel tank protector (LH) | 9. Fuel tank mounting band (RH) |
| 10. Fuel tank protector | 11. Fuel tank mounting band (LH) | 12. Clamp |
| 13. Fuel filler hose | 14. Clamp | 15. Fuel filler tube |

- A. The measurement of hexagonal width across flats: 16 mm (0.63 in)
- B. The measurement of hexagonal width across flats: 17 mm (0.67 in)

Refer to GI-4, "Components" for symbols in the figure.

- In regard to the notation of torque in the figure, (A) shows an ISO standard, (B) shows a conventional standard.

Removal and Installation

INFOID:000000006187263

WARNING:

Be sure to read "General Precautions" when working on the fuel system. Refer to FL-2, "General Precautions".

REMOVAL

- Drain fuel from fuel tank if necessary. Refer to FL-6, "Removal and Installation".
 - Perform work on level place.
1. Perform steps 2 to 7 of "REMOVAL" in "FUEL LEVEL SENSOR UNIT, FUEL FILTER AND FUEL PUMP ASSEMBLY" on main fuel level sensor unit, fuel filter and fuel pump assembly and sub fuel level sensor unit. Refer to FL-6, "Removal and Installation".

FUEL TANK

< ON-VEHICLE REPAIR >

2. Remove center muffler. Refer to EX-5, "Exploded View".
3. Remove propeller shaft. Refer to DLN-79, "Exploded View".
4. Remove parking rear brake cables. Refer to PB-4, "Exploded View".
5. Remove rear suspension member assembly. Refer to RSU-17, "Exploded View".

NOTE:

For this service, drive shaft, final drive, and rear suspension member are required not to be separate one another during removal.

6. Remove fuel tank protectors.
7. Disconnect fuel filler hose, EVAP hose, and Vent hose from the side other than the fuel tank side.

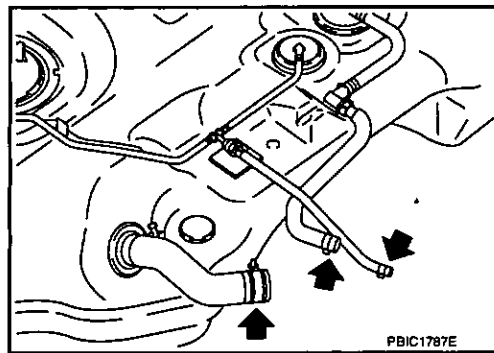

8. Support the lower part of fuel tank (1) with transmission jack (A).
CAUTION:
 Support the position that fuel tank mounting bands never engage.

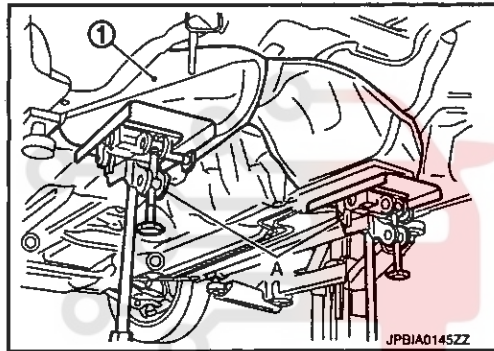

9. Remove fuel tank mounting bands.
10. Supporting with hands, descend transmission jack carefully, and remove fuel tank.
CAUTION:
 - Check that all connection points have been disconnected.
 - Confirm there is no interference with vehicle.
11. Remove fuel filler tube if necessary.

INSTALLATION

Note the following, and install in the reverse order of removal.

- Surely clamp fuel hoses and insert hose to the length below.

Fuel filler hose	: 35 mm (1.38 in)
The other hoses	: 25 mm (0.98 in)

- Be sure hose clamp is not placed on swelled area of fuel tube.
- Tighten fuel filler hose clamp so that the remaining length of screw thread becomes to the following.

Fuel filler tube side	: 7 - 11 mm (0.28 - 0.43 in)
Fuel tank side	: 5 - 9 mm (0.20 - 0.35 in)

- To connect quick connector, refer to FL-6, "Removal and Installation".

Inspection

INSPECTION AFTER INSTALLATION

Use the following procedure to check for fuel leakage.

INFOID:000000006187264

FUEL TANK

< ON-VEHICLE REPAIR >

1. Turn ignition switch "ON" (with engine stopped), and check connections for leakage by applying fuel pressure to fuel piping.
 2. Start engine and rev it up and check there are no fuel leakage at the fuel system tube and hose connections.
- After removing/installing rear suspension assembly, check to adjust wheel alignment and then, adjust neutral position of steering angle sensor. Refer to RSU-5. "Inspection" and BRC-9. "ADJUSTMENT OF STEERING ANGLE SENSOR NEUTRAL POSITION : Description".

دیجیتال خودرو

شرکت دیجیتال خودرو سامانه (مسئولیت محدود)

اولین سامانه دیجیتال تعمیرکاران خودرو در ایران

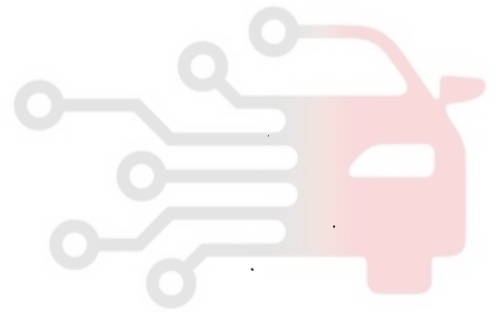

SERVICE DATA AND SPECIFICATIONS (SDS)

< SERVICE DATA AND SPECIFICATIONS (SDS)

SERVICE DATA AND SPECIFICATIONS (SDS)

SERVICE DATA AND SPECIFICATIONS (SDS)

Fuel Tank

INFOID:000000006187285

Standard and Limit

Fuel tank capacity	Approx. 82 ℓ (18 Imp gal)
Fuel recommendation	Refer to <u>GI-29</u>

دیجیتال خودرو

شرکت دیجیتال خودرو سامانه (مسئولیت محدود)

اولین سامانه دیجیتال تعمیرکاران خودرو در ایران

