

Air conditioning system

G-1a

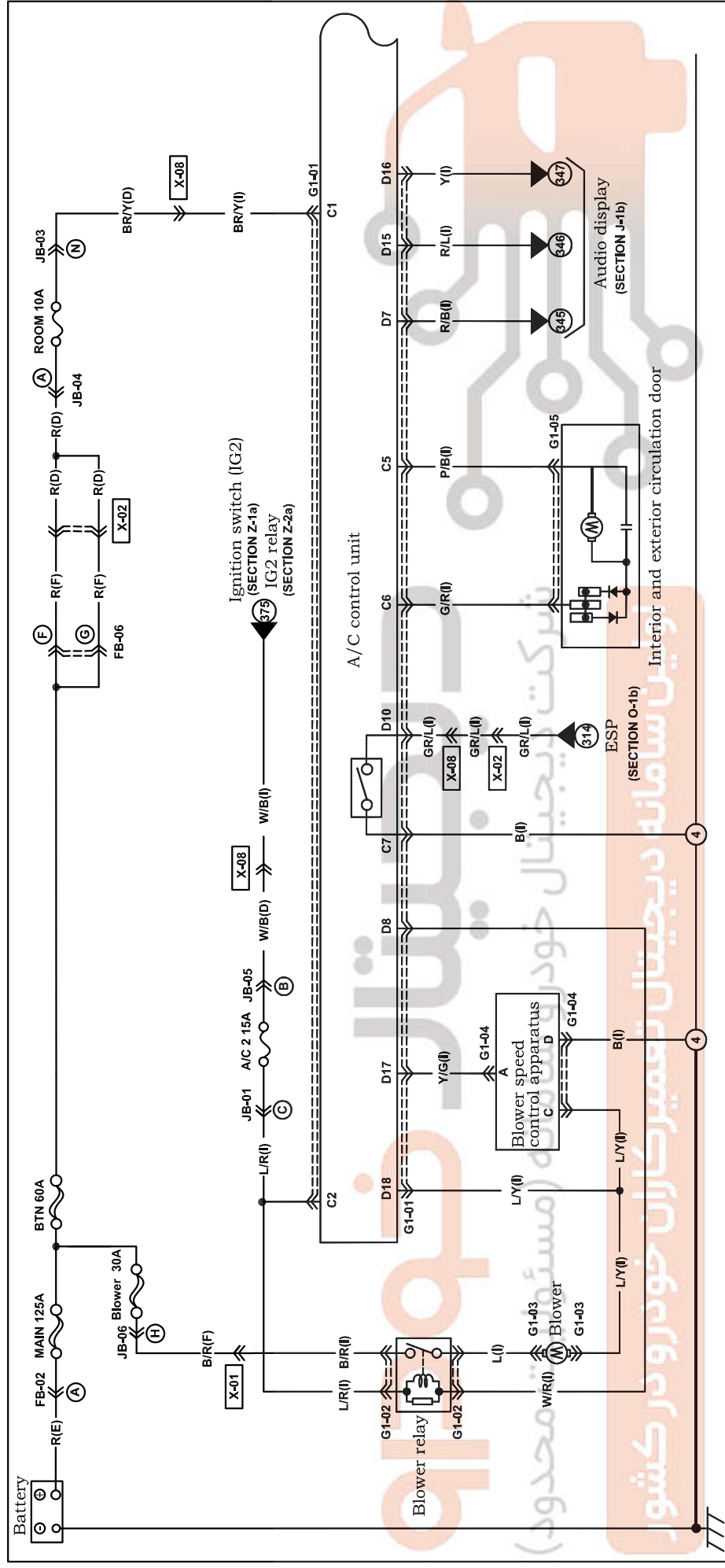

<p><b>G1-01</b> A/C control unit (I)</p> <table border="1"> <tr> <td>C1</td> <td>BRY (I)</td> <td>Y/R</td> <td>Y/L</td> <td>P/B</td> <td>G/R</td> <td>B/W</td> </tr> <tr> <td>C6</td> <td>L/R</td> <td>Y/R</td> <td>Y/L</td> <td>P/B</td> <td>G/R</td> <td>B/W</td> </tr> <tr> <td>C7</td> <td>B</td> <td>W</td> <td>W/B</td> <td>W/G</td> <td>G</td> <td></td> </tr> <tr> <td>D1</td> <td>LG</td> <td>L/R</td> <td>L/W</td> <td>R/G</td> <td>L</td> <td>O</td> </tr> <tr> <td>D10</td> <td>GR/L</td> <td></td> <td></td> <td></td> <td></td> <td></td> </tr> <tr> <td>D11</td> <td>LG/B</td> <td>V</td> <td>Y/B</td> <td>W/L</td> <td>R/L</td> <td>Y</td> </tr> <tr> <td>D20</td> <td></td> <td></td> <td></td> <td></td> <td></td> <td></td> </tr> </table>	C1	BRY (I)	Y/R	Y/L	P/B	G/R	B/W	C6	L/R	Y/R	Y/L	P/B	G/R	B/W	C7	B	W	W/B	W/G	G		D1	LG	L/R	L/W	R/G	L	O	D10	GR/L						D11	LG/B	V	Y/B	W/L	R/L	Y	D20							<p><b>G1-02</b> Blower relay (I)</p>	<p>( ) with ESP</p> <table border="1"> <tr> <td>D10</td> <td>GR/L</td> <td>*</td> <td>*</td> <td>*</td> </tr> <tr> <td>D20</td> <td></td> <td>*</td> <td>*</td> <td>*</td> </tr> </table>	D10	GR/L	*	*	*	D20		*	*	*	<p><b>G1-03</b> Blower (I)</p> <table border="1"> <tr> <td>L</td> <td>L/Y</td> </tr> </table>	L	L/Y	<p><b>G1-04</b> Blower speed control apparatus (I)</p> <table border="1"> <tr> <td>L/Y</td> <td>Y/G</td> <td>*</td> </tr> <tr> <td>B</td> <td></td> <td></td> </tr> </table>	L/Y	Y/G	*	B			<p><b>G1-05</b> Interior and exterior circulation door (I)</p> <table border="1"> <tr> <td>P/B</td> <td>*</td> <td>*</td> <td>*</td> <td>*</td> <td>G/R</td> </tr> </table>	P/B	*	*	*	*	G/R	
C1	BRY (I)	Y/R	Y/L	P/B	G/R	B/W																																																																									
C6	L/R	Y/R	Y/L	P/B	G/R	B/W																																																																									
C7	B	W	W/B	W/G	G																																																																										
D1	LG	L/R	L/W	R/G	L	O																																																																									
D10	GR/L																																																																														
D11	LG/B	V	Y/B	W/L	R/L	Y																																																																									
D20																																																																															
D10	GR/L	*	*	*																																																																											
D20		*	*	*																																																																											
L	L/Y																																																																														
L/Y	Y/G	*																																																																													
B																																																																															
P/B	*	*	*	*	G/R																																																																										

Harness mark:  (F)  (E)  (D)  (R)

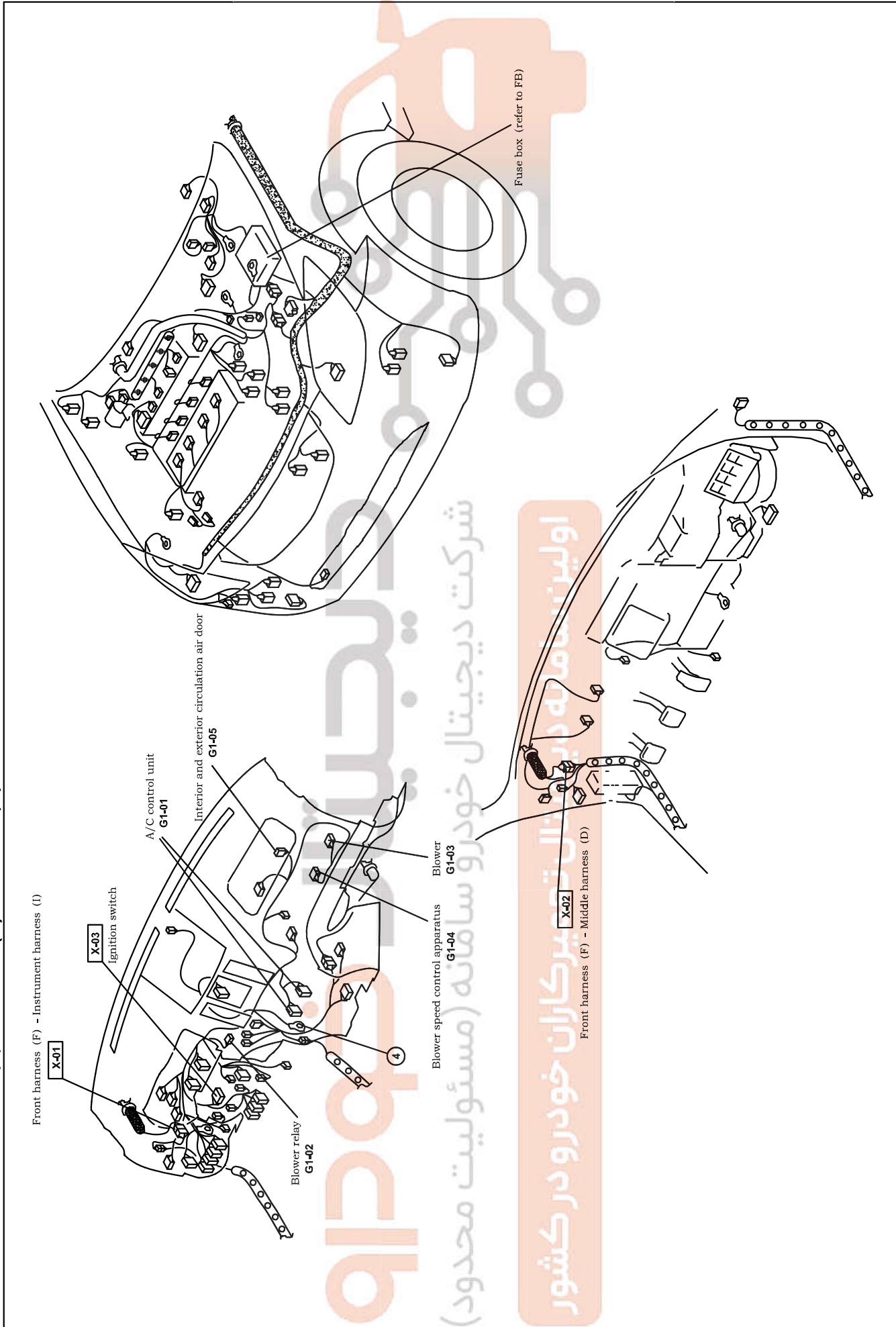

اولین مجموعه دیجیتال خودرو خودروسازان کشور  
 شرکت دیجیتال خودرو سامنه (مسئولیت محدود)

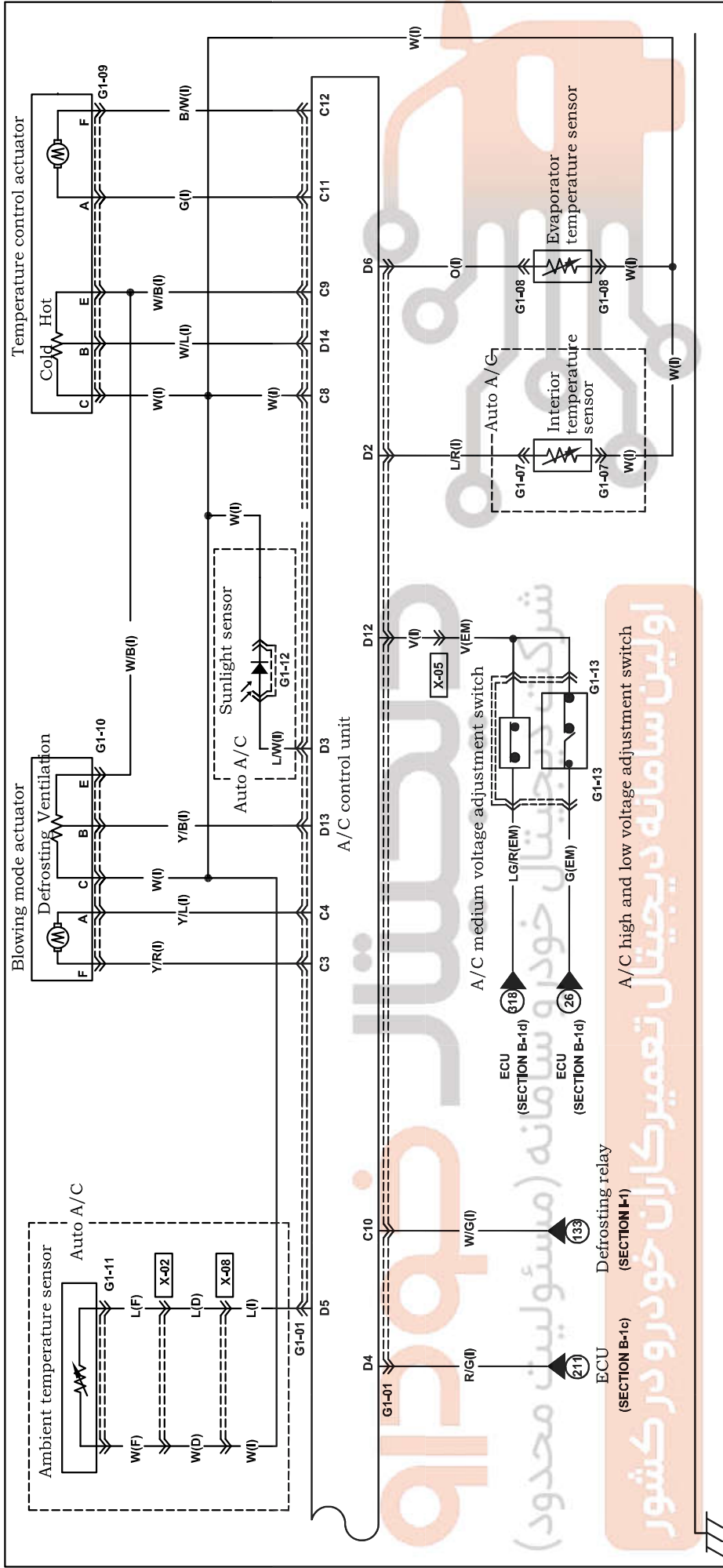

Air conditioning system

G-1b



A/C high and low voltage adjustment switch  
 اولین سامانه دیجیتال تعمیرکاران خودرو کشور

<p><b>G1-01</b> A/C control unit (I)</p> <table border="1"> <tr> <td>C1</td> <td>BRY</td> <td>L/R</td> <td>Y/R</td> <td>Y/L</td> <td>P/B</td> <td>G/R</td> <td></td> </tr> <tr> <td>B</td> <td>W</td> <td>W</td> <td>W/B</td> <td>W/G</td> <td>G</td> <td>B/W</td> <td></td> </tr> <tr> <td>C6</td> <td></td> <td></td> <td></td> <td></td> <td></td> <td></td> <td></td> </tr> <tr> <td>C7</td> <td></td> <td></td> <td></td> <td></td> <td></td> <td></td> <td></td> </tr> </table>	C1	BRY	L/R	Y/R	Y/L	P/B	G/R		B	W	W	W/B	W/G	G	B/W		C6								C7								<p><b>G1-07</b> Interior temperature sensor (I)</p> <p><b>G1-11</b> Ambient temperature sensor (F)</p>	<p><b>G1-08</b> Evaporator temperature sensor (I)</p> <p><b>G1-12</b> Sunlight sensor (I)</p>	<p>( ) with ESP</p> <table border="1"> <tr> <td>D1</td> <td>LG</td> <td>L/R</td> <td>L/W</td> <td>R/G</td> <td>L</td> <td>O</td> <td>R/B</td> <td>W/R</td> <td>*</td> <td>GR/L</td> </tr> <tr> <td>D10</td> <td>LG/B</td> <td>V</td> <td>Y/B</td> <td>W/L</td> <td>R/L</td> <td>Y</td> <td>Y/G</td> <td>L/Y</td> <td>*</td> <td>D20</td> </tr> </table>	D1	LG	L/R	L/W	R/G	L	O	R/B	W/R	*	GR/L	D10	LG/B	V	Y/B	W/L	R/L	Y	Y/G	L/Y	*	D20
C1	BRY	L/R	Y/R	Y/L	P/B	G/R																																																			
B	W	W	W/B	W/G	G	B/W																																																			
C6																																																									
C7																																																									
D1	LG	L/R	L/W	R/G	L	O	R/B	W/R	*	GR/L																																															
D10	LG/B	V	Y/B	W/L	R/L	Y	Y/G	L/Y	*	D20																																															
<p><b>G1-09</b> Temperature control actuator (I)</p> <table border="1"> <tr> <td>B/W</td> <td>W/B</td> <td>*</td> <td>W</td> <td>W/L</td> <td>G</td> </tr> <tr> <td>F</td> <td></td> <td></td> <td></td> <td></td> <td>A</td> </tr> </table>	B/W	W/B	*	W	W/L	G	F					A	<p><b>G1-10</b> Blowing mode actuator (I)</p> <table border="1"> <tr> <td>G</td> <td></td> <td></td> <td></td> <td></td> <td></td> </tr> <tr> <td>W</td> <td>*</td> <td>W/B</td> <td>*</td> <td></td> <td></td> </tr> <tr> <td>Y/L</td> <td>Y/B</td> <td>Y/R</td> <td>*</td> <td></td> <td>B</td> </tr> <tr> <td>H</td> <td></td> <td></td> <td></td> <td></td> <td></td> </tr> </table>	G						W	*	W/B	*			Y/L	Y/B	Y/R	*		B	H						<p><b>G1-13</b> A/C pressure switch (EM)</p>																			
B/W	W/B	*	W	W/L	G																																																				
F					A																																																				
G																																																									
W	*	W/B	*																																																						
Y/L	Y/B	Y/R	*		B																																																				
H																																																									

Harness mark:  (F)  (E)  (D)  (R)

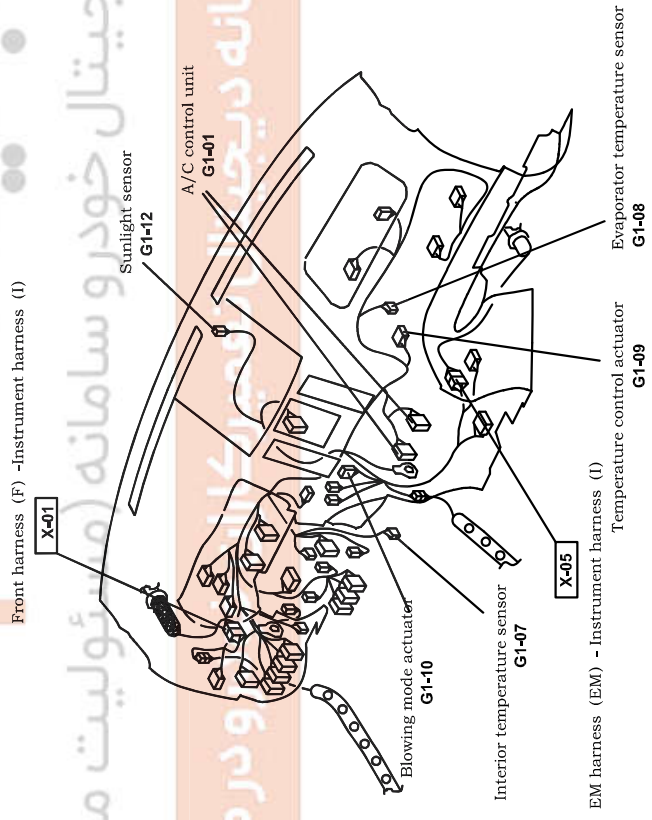
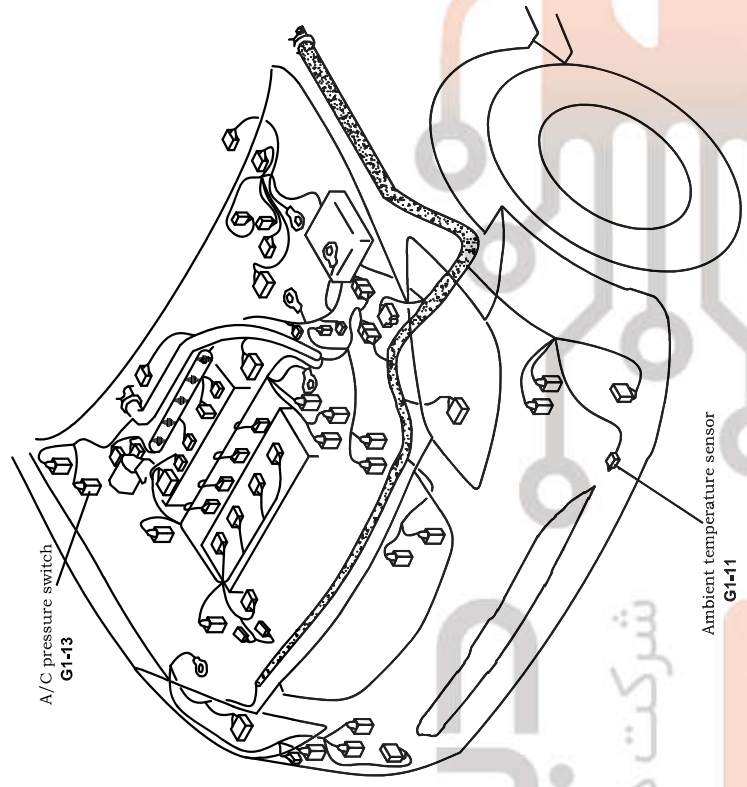

دیجیتال خودرو

شرکت دیجیتال خودرو سامانه (مستقلیت محدود)

اولین سامانه دیجیتال خودرو کشور

G-2

Compressor control system

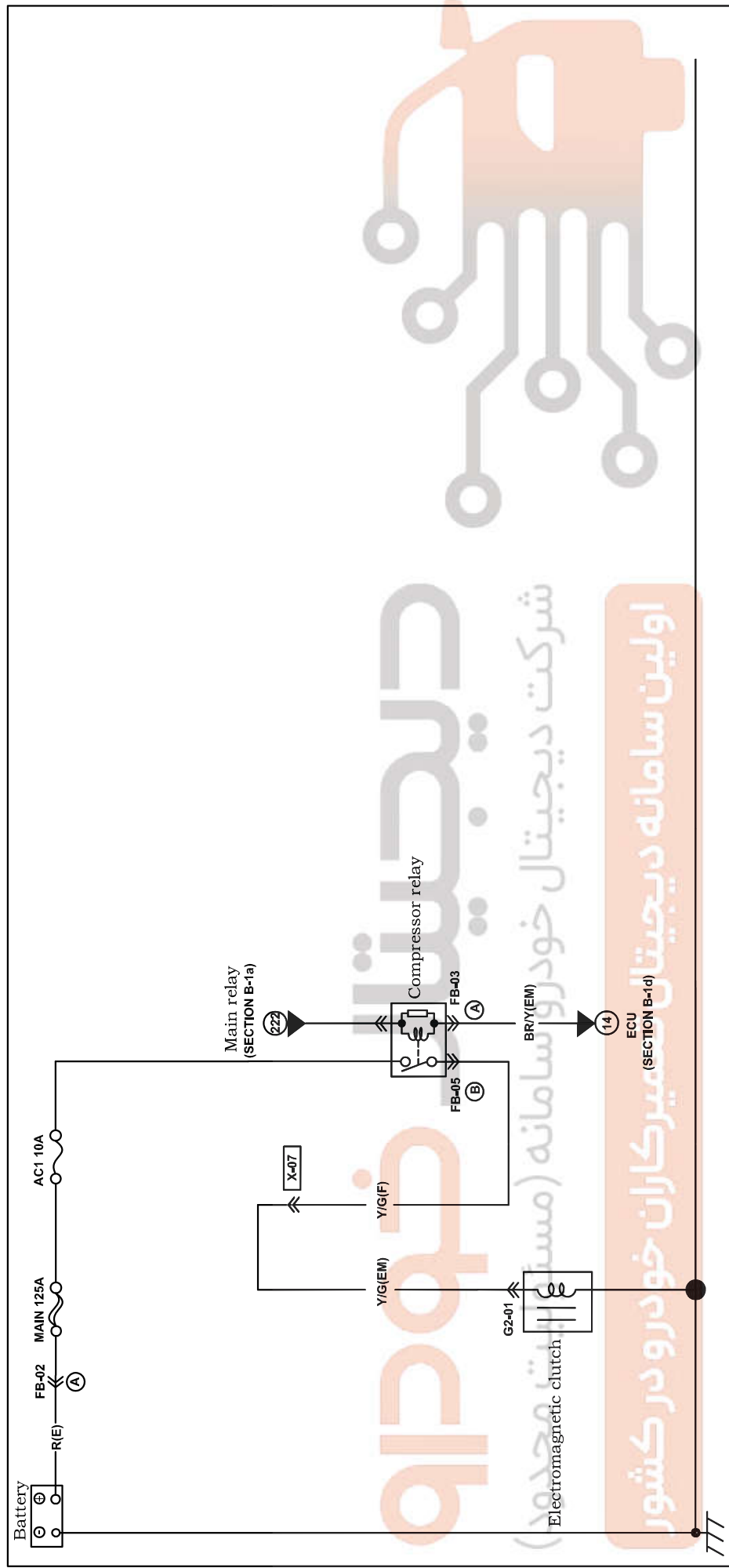

G2-01 Electromagnetic clutch (EM)						
						

Harness mark:  (F)  (E)  (D)  (R)

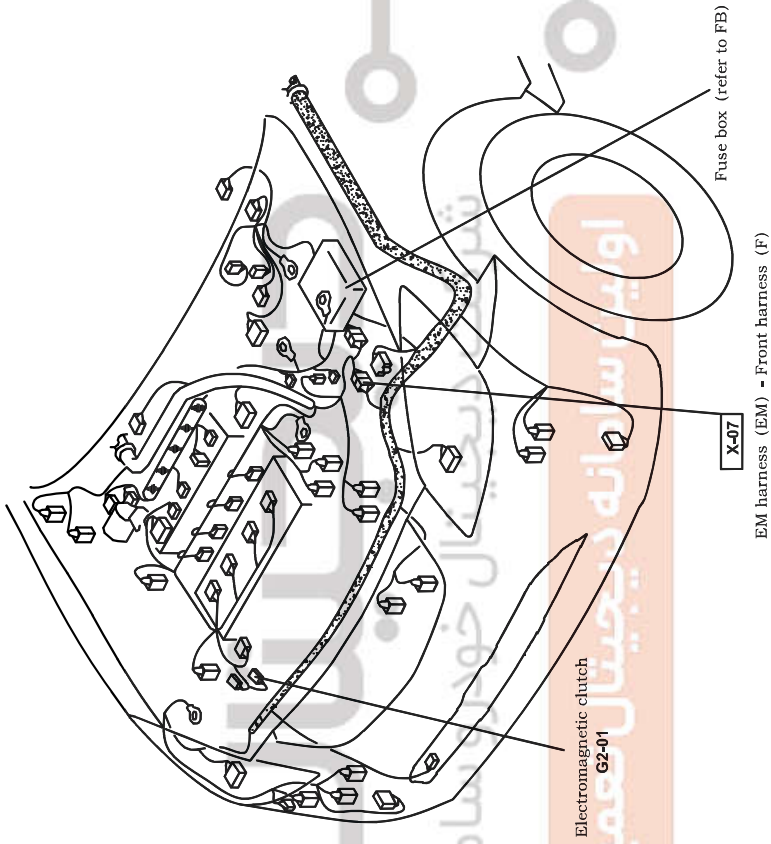

خودرو

مستولیت محدود

اوبیرسانه دیجیتال معمیرکاران خودرو در کشور