

EM-2

Engine Mechanical System

General Information

Specifications

Description	Specification 2.0(D4EA)	Limit
General		
Type	In-line, Single Overhead Camshaft	
Number of cylinders	4	
Bore	83mm (3.27in.)	
Stroke	92mm (3.62in.)	
Total displacement	1991cc (121.5cu.in.)	
Compression ratio	17.3 : 1	
Firing order	1 - 3 - 4 - 2	
Valve timing		
Intake valve		
Opens (BTDC)	7°	
Closes (ABDC)	43°	
Exhaust valve		
Opens (BBDC)	52°	
Closes (ATDC)	6°	
Cylinder head		
Flatness of gasket surface	0.03mm (0.0012in.) for width	
	0.09mm (0.0035in.) for length	
	0.012mm. (0.00047in.) / 51×51mm	
Camshaft		
Cam height		
Intake	34.697mm (1.366in.)	34.197mm (1.346in.)
Exhaust	34.570mm (1.361in.)	34.070mm (1.341in.)
Journal O.D	28mm (1.10in.)	
Bearing oil clearance	0.040 ~ 0.074mm (0.0020 ~ 0.0029in.)	
End play	0.05 ~ 0.15mm (0.002 ~ 0.006in.)	
Valve		
Valve length		
Intake	95.7mm (3.77in.)	
Exhaust	95.4mm (3.76in.)	
Stem O.D.		
Intake	5.953mm (0.234in.)	
Exhaust	5.925mm (0.233in.)	

General Information

EM-3

Description	Specification 2.0(D4EA)	Limit
Face angle	44.5°	
Thickness of valve head (margin)		
Intake	1.6mm (0.063in.)	
Exhaust	1.3mm (0.0512in.)	
Valve stem to valve guide clearance		
Intake	0.022 ~ 0.067mm (0.00086 ~ 0.00263in.)	0.1mm (0.0039in.)
Exhaust	0.050 ~ 0.095mm (0.0020 ~ 0.0037in.)	0.15mm (0.0059in.)
Valve guide		
Length		
Intake	36.5mm (1.437in.)	
Exhaust	36.5mm (1.437in.)	
Valve seat		
Width of seat contact	1.21mm (0.0477in.) / 1.61mm (0.0634in.) (IN/EX)	
Seat angle	44° ~ 44.5°	
Valve spring		
Free length	38.8mm (1.527in.)	
Load	21.25kg/32mm (47.2lb/1.26in.) at installed height	
Cylinder block		
Cylinder bore	83 + 0.03mm (3.27 + 0.0012in.)	
Flatness of gasket surface	0.042mm (0.00165in.) for width 0.096mm (0.00378in.) for length 0.012mm (0.00047in.) / 50×50mm	
Piston		
O.D	82.92 ~ 82.95mm (3.26 ~ 3.27in.)	
Piston-to-cylinder clearance	0.07 ~ 0.09mm (0.0027 ~ 0.0036in.)	
Ring groove width		
No.1	1.915 ~ 1.945mm (0.075 ~ 0.076in.)	
No.2	2.06 ~ 2.08mm (0.08 ~ 0.082in.)	
Oil	3.02 ~ 3.04mm (0.119 ~ 0.1196in.)	
Service size	0.25mm (0.010in.), 0.5mm (0.020in.) oversize	
Piston ring		
Side clearance		
No.1	0.064 ~ 0.114mm (0.00252 ~ 0.00449in.)	
No.2	0.065 ~ 0.11mm (0.00256 ~ 0.00433in.)	

EM-4

Engine Mechanical System

Description		Specification 2.0(D4EA)	Limit
Oil ring		0.03 ~ 0.07mm (0.00118 ~ 0.00275in.)	
End gap			
No.1		0.2 ~ 0.3mm (0.0079 ~ 0.0118in.)	
No.2		0.3 ~ 0.45mm (0.0118 ~ 0.0177in.)	
Oil ring side rail		0.2 ~ 0.45mm (0.0079 ~ 0.0177in.)	
Connecting rod			
Connecting rod pin O.D		28.022 ~ 28.034mm (1.103 ~ 1.104in.)	
Connecting rod bearing oil clearance		0.024 ~ 0.042mm (0.0009 ~ 0.0016in.)	
Crankshaft main bearing oil clearance		0.024 ~ 0.042mm (0.0009 ~ 0.0016in.)	
Crankshaft			
Journal O.D.		60.002 ~ 60.020mm (2.362 ~ 2.363in.)	
Pin O.D.		50.008 ~ 50.026mm (1.9688 ~ 1.9695in.)	
Out-of-round of journal and pin		Less than 0.0035mm (0.0001in.)	
Taper of journal and pin		Less than 0.006mm (0.0002in.)	
End play		0.09 ~ 0.32mm (0.0035 ~ 0.0126in.)	
Flywheel			
Runout		0.13mm/Ø238	0.13mm (0.0051in.)
Engine oil			
Oil quantity	Total	6.6 L (6.97 US qt, 5.80 Imp qt)	When replacing a short engine or a block assembly
	Oil pan	5.4 L (5.70 US qt, 4.74 Imp qt)	
	Drain and refill	5.9 L (6.23 US qt, 5.18 Imp qt)	Including oil filter
Oil grade	Classification	ACEA C3 (with CPF) ACEA B4 (without CPF)	
	SAE viscosity grade	Recommended SAE viscosity number	Refer to the "Lubrication System"
Oil pressure (at idle)		78.45kPa (0.8kg/cm ² , 11.38psi) or above	Oil temperature in oil pan : 80°C (176°F)
Oil pump			
Tip clearance		0.12 ~ 0.2mm (0.00472 ~ 0.0078in.)	
Radial clearance		0.13 ~ 0.23mm (0.0051 ~ 0.009in.)	
Side clearance		0.02 ~ 0.07mm (0.00078 ~ 0.0027in.)	
Oil pressure (at 1,500rpm) [Oil Temperature is 95~105°C (203~221 °F), SEA 10W-30]		More than 18l/min (0.00106ft ³ /s) 4.0kgf/cm ² (8192lbf/ft ²)	
Relief spring			

General Information

EM-5

Description	Specification 2.0(D4EA)	Limit
Freen length	47.5mm (1.835in.)	
Opening pressure	570 ± 50kPa (82.67 ± 7.25psi)	
Silent shaft		
Front journal diameter	27.99 ~ 28.01mm (1.102 ~ 1.1027in.)	
Rear journal diameter	41.99 ~ 42.01mm (1.6531 ~ 1.6539in.)	
Oil clearacne		
Front	0.050 ~ 0.09mm (0.0020 ~ 0.0036in.)	
Rear	0.050 ~ 0.091mm (0.0020 ~ 0.0036in.)	
Cooling method		
Cooling system quantity (Radiator)	Forced circulation with electrical fan 5 lit (5.3U.S.qts, 4.4 Imp.qts)	
Thermostat		
Type		
Normal opening temperature	Wax pellet type with jiggle valve	
Opening temperature range	85°C (185°F)	
Full opening temperature	83.5 ~ 86.5°C (182 ~ 188°F)	
Radiator cap	100°C (212°F)	
Main valve openg pressure	107.9 ± 14.7kPa (1.1±0.15kg/cm ² , 15.64±2.13psi)	
Main valve closing pressure	83.4kPa (0.85kg/cm ² , 12.1psi)	
Vacuum valve opening pressure	-6.86kPa (-0.07kg/cm ² , -1.00psi)	
Air cleaner		
Type	Dry type	
Element	Unwoven cloth type	
Exhaust		
Muffler	Expansion resonance type	
Suspension system	Rubber hangers	
Coolant tempreature sensor		
Type	Thermister type	
Resistance		
20°C (68°F)	2.45 ± 0.14kΩ	
80°C (176°F)	0.3222kΩ	

EM-6**Engine Mechanical System****Service Standards**

Standard value	
Coolant concentration	
Tropical area	40%
Other area	50%

Sealant

Engine coolant temperature sensor	LOCITITE 262, three bond No. 1324 or equivalent
Oil pressure switch	3M ATD No. 8660 or Three bond No. 1141E
Bed plate	LOCITITE 5205, DREIBOND 5105 or HYLOMAR 3000

NOTICE

O.D. = Outer Diameter

I.D. = Inner Diameter

O.S. = Oversize Diameter

U.S. = Undersize Diameter

دیجیتال خودرو

شرکت دیجیتال خودرو سامانه (مسئولیت محدود)

اولین سامانه دیجیتال تعمیرکاران خودرو در ایران



General Information

EM-7

Tightening Torques

Item	N.m	kgf.m	lb-ft
Engine mounting insulator bolt	50 ~ 65	5.0 ~ 6.5	36 ~ 47
Engine mounting bracket nuts	60 ~ 80	6.0 ~ 8.0	43 ~ 59
Engine mounting bracket bolt	50 ~ 65	5.0 ~ 6.5	36 ~ 47
Engine support bracket bolt	43 ~ 55	4.3 ~ 5.5	32 ~ 40
Front roll stopper bracket to sub frame bolts	50 ~ 65	5.0 ~ 6.5	36 ~ 47
Front roll stopper insulator bolt and nut	50 ~ 65	5.0 ~ 6.5	36 ~ 47
Rear roll stopper bracket to sub frame bolts	50 ~ 65	5.0 ~ 6.5	36 ~ 47
Rear roll stopper insulator bolt and nut	50 ~ 65	5.0 ~ 6.5	36 ~ 47
Transaxle mounting bracket bolts	50 ~ 65	5.0 ~ 6.5	36 ~ 47
Transaxle mounting insulator bolt	90 ~ 110	9.0 ~ 11	65 ~ 80
Front exhaust pipe to exhaust manifold	40 ~ 60	4.0 ~ 6.0	30 ~ 43
Head cover bolt	8 ~ 10	0.8 ~ 1.0	6 ~ 7
Camshaft sprocket bolt	125 ~ 140	12.5 ~ 14.0	92 ~ 103
Camshaft bearing cap bolt	26.5 ~ 29.5	2.65 ~ 2.95	20 ~ 22
Crankshaft position sensor	4 ~ 6	0.4 ~ 0.6	3 ~ 4.4
Crankshaft sprocket bolt	185 ~ 195	18.5 ~ 19.5	136 ~ 144
Damper pulley to crankshaft sprocket	30 ~ 34	3.0 ~ 3.4	22 ~ 25
Cylinder head bolt (cold engine)	50+120°+120°	5.0+120°+120°	36+120°+120°
Timing belt auto tensioner bolt	50 ~ 55	5.0 ~ 5.5	36 ~ 40
Drive belt auto tensioner bolt	26 ~ 30	2.6 ~ 3.0	19 ~ 23
Timing belt auto tensioner adjustable bolt	10 ~ 12	1.0 ~ 1.2	7 ~ 9
Drive belt idler bolt	46 ~ 51	4.6 ~ 5.1	34 ~ 38
Oil pan	10 ~ 12	1.0 ~ 1.2	7 ~ 9
Oil pan drain plug	35 ~ 45	3.5 ~ 4.5	25 ~ 33
Oil screen	10 ~ 12	1.0 ~ 1.2	7 ~ 9
Oil pressure switch	15 ~ 22	1.5 ~ 2.2	11 ~ 16
Oil screen bracket bolt	34 ~ 38	3.4 ~ 3.8	25 ~ 28
Oil pump bolt	20 ~ 27	2.0 ~ 2.7	15 ~ 20
Plug cap	20 ~ 27	2.0 ~ 2.7	14 ~ 20
Oil jet bolt	9 ~ 13	0.9 ~ 1.3	7 ~ 10
Oil pump rotor bolt	8 ~ 10	0.8 ~ 1.0	6 ~ 7
Timing belt upper cover	8 ~ 12	0.8 ~ 1.2	6 ~ 9
Timing belt lower cover	8 ~ 12	0.8 ~ 1.2	6 ~ 9
Relief plug	12 ~ 52	1.2 ~ 5.2	31 ~ 38

EM-8

Engine Mechanical System

Item	N.m	kgf.m	lb-ft
Flywheel	70 ~ 80	7.0 ~ 8.0	52 ~ 59
Drive plate	70 ~ 80	7.0 ~ 8.0	52 ~ 59
Connecting rod bolt	25+90°	2.5+90°	180+90°
Engine coolant pump to cylinder block bolt			
14mm	48 ~ 52	4.8 ~ 5.2	35 ~ 38
10mm	10 ~ 12	1.0 ~ 1.2	7 ~ 9
Engine coolant temperature sensor	20 ~ 40	2.0 ~ 4.0	15 ~ 30
Engine coolant inlet fitting attaching bolt	20 ~ 25	2.0 ~ 2.5	15 ~ 18
Air cleaner mounting bolts	8 ~ 10	0.8 ~ 1.0	6 ~ 7
Resonator mounting bolt (Nut)	8 ~ 10	0.8 ~ 1.0	6 ~ 7
Intake manifold mounting bolt (M8)	15 ~ 22	1.5 ~ 2.2	11 ~ 16
Hanger bolt to body	10 ~ 15	1.0 ~ 1.5	7 ~ 11
Hanger bolt to main muffler	10 ~ 15	1.0 ~ 1.5	7 ~ 11
Exhaust manifold nuts	30 ~ 35	3.0 ~ 3.5	22 ~ 26
Heat protector bolt to exhaust manifold	15 ~ 20	1.5 ~ 2.0	11 ~ 14
Air cleaner bracket bolt	10 ~ 13	1.0 ~ 1.3	7 ~ 9
Oil level gauge	10 ~ 12	1.0 ~ 1.2	7 ~ 9
Balance shaft bolt	53 ~ 57	5.3 ~ 5.7	39 ~ 42
Starter bolt to cylinder block	48 ~ 52	4.8 ~ 5.2	35 ~ 38
Turbocharger support bolt	35 ~ 45	3.5 ~ 4.5	26 ~ 33
Crankshaft bedplate bolt			
15mm	28 ~ 35+120°	2.8 ~ 3.5+120°	20.65 ~ 23.6+120°
12mm	33.7 ~ 37.7	3.37 ~ 37.7	24.9 ~ 27.8

General Information

EM-9

Compression Pressure Inspection

NOTICE

- If there is lack of power, excessive oil consumption or poor fuel economy, measure the compression pressure.
 - Whenever removing injectors for compression pressure inspection, replace the gaskets with new ones and tighten them with the specified torque.
1. Warm up engine until the normal operating temperature.
 2. Remove the ECM fuse or fuel pump relay.
 3. Remove the injectors. (Refer to Injector in FL Group)
 4. Check the cylinder compression pressure.
 - 1) Insert a compression gauge SST(09351-27000, 09351-27500) into the injector hole.

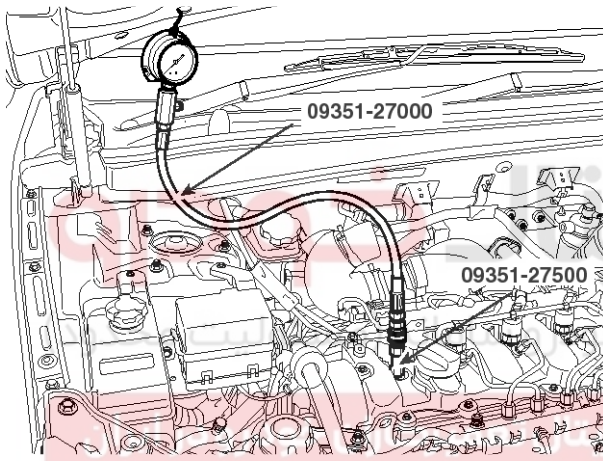

SCMEM7010L

- 2) Fully open the throttle.
- 3) While cranking the engine, measure the compression pressure.

NOTICE

Always use a fully charged battery to obtain engine speed of 270rpm or more.

- 4) Repeat step 1) through 3) for each cylinder.

NOTICE

This measurement must be done in as short a time as possible.

Compression pressure :

2,549.72kPa (26.0kg/cm², 369.81psi) (270 rpm)

Minimum pressure :

2,255.52kPa (23.0kg/cm², 327.14psi)

Difference between each cylinder :

294.20kPa (3.0kg/cm², 42.67psi) or less

- 5) If the cylinder compression in 1 or more cylinders is low, pour a small amount of engine oil into the cylinder through the spark plug hole and repeat step 1) through 3) for cylinders with low compression.

- If adding oil helps the compression, it is likely that the piston rings and/or cylinder bore are worn or damaged.
- If pressure stays low, a valve may be sticking or seating is improper, or there may be leakage past the gasket.

5. Reinstall the injectors. (Refer to Injector in FL Group)

EM-10

Engine Mechanical System

Troubleshooting

Symptom	Suspect	Remedy
Engine misfire with abnormal internal lower engine noises.	Loose or improperly installed engine flywheel.	Repair or replace the flywheel as required.
	Worn piston rings (Oil consumption may or may not cause the engine to misfire.)	Inspect the cylinder for a loss of compression. Repair or replace as required.
	Worn crankshaft thrust bearings.	Replace the crankshaft and bearings as required.
Engine misfire with abnormal valve train noise.	Stuck valves (Carbon buildup on the valve stem can cause the valve not to close properly.)	Repair or replace as required
	Excessive worn or mis-aligned timing belt	Replace the timing belt and sprocket as required.
	Worn camshaft lobes.	Replace the camshaft and valve lifters.
Engine misfire with coolant consumption.	<ul style="list-style-type: none"> Faulty cylinder head gasket and/or cranking or other damage to the cylinder head and engine block cooling system. Coolant consumption may not cause the engine to overheat. 	<ul style="list-style-type: none"> Inspect the cylinder head and engine block for damage to the coolant passages and/or a faulty head gasket. Repair or replace as required.
Engine misfire with excessive oil consumption.	Worn valves, valve guides and/or valve stem oil seals.	Repair or replace as required.
	Worn piston rings. (Oil consumption may or may not cause the engine to misfire)	<ul style="list-style-type: none"> Inspect the cylinder for a loss of compression. Repair or replace as required.
Engine noise on start-up, but only lasting a few seconds.	Incorrect oil viscosity.	<ul style="list-style-type: none"> Drain the oil Install the correct viscosity oil.
	Worn crankshaft thrust bearing.	<ul style="list-style-type: none"> Inspect the thrust bearing and crankshaft. Repair or replace as required.
Upper engine noise, regardless of engine speed.	Low oil pressure.	Repair or replace as required.
	Broken valve spring.	Replace the valve spring
	Worn or dirty valve lifters.	Replace the valve lifters.
	Stretched or broken timing belt and/or damaged sprocket teeth.	Replace the timing belt and sprockets.
	Worn timing chain tensioner, if applicable.	Replace the timing chain tensioner as required.
	Worn camshaft lobes.	<ul style="list-style-type: none"> Inspect the camshaft lobes. Replace the timing camshaft and valve lifters as required.
	Worn valve guides or valve stems.	Inspect the valves and valve guides, then repair as required.
	Stuck valves. (Carbon on the valve stem or valve seat may cause the valve to stay open.)	Inspect the valves and valve guides, then repair as required.

General Information

EM-11

Symptom	Suspect	Remedy
Lower engine noise, regardless of engine speed.	Low oil pressure.	Repair or replace damaged components as required.
	Loose or damaged flywheel.	Repair or replace the flywheel.
	Damaged oil pan, contacting the oil pump screen.	<ul style="list-style-type: none"> Inspect the oil pan. Inspect the oil pump screen. Repair or replace as required.
	Oil pump screen loose, damage or restired.	<ul style="list-style-type: none"> Inspect the oil pump screen. Repair or replace as required.
	Excessive piston-to-cylinder bore clearance.	<ul style="list-style-type: none"> Inspect the piston and cylinder bore. Repair as required.
	Excessive piston pin-to bore clearance.	<ul style="list-style-type: none"> Inspect the piston, piston pin and the connecting rod. Repair or replace as required.
	Excessive connecting rod bearing clearance	Inspect the following components and repair as required. <ul style="list-style-type: none"> The connecting rod bearings. The connecting rods. The crankshaft. The crankshaft journal.
	Excessive crankshaft bearing clearance	Inspect the following components and repair as required. <ul style="list-style-type: none"> The crankshaft bearings. The crankshaft journals.
Incorrect piston, piston pin and connecting rod installation	<ul style="list-style-type: none"> Verify the piston pins and connecting rods are installed correctly. Repair as required. 	
Engine noise under load	Low oil pressure	Repair or replace as required.
	Excessive connecting rod bearing clearance	Inspect the following components and repair as required. <ul style="list-style-type: none"> The connecting rod bearings. The connecting rods. The crankshaft
	Excessive crankshaft bearing clearnace	Inspect the following components, and repair as required. <ul style="list-style-type: none"> The crankshaft bearings. The crankshaft journals. The cylinswe block crankshaft bearing bore

EM-12

Engine Mechanical System

Symptom	Suspect	Remedy
Engine will not crank- crakshaft will not rotat- e	Hydraulically cylinder <ul style="list-style-type: none"> Coolant/antifreeze in cylinder. Oil in cylinder. Fuel in cylinder 	<ol style="list-style-type: none"> Remove injectors and check for fluid. Inspect for broken head gasket. Inspect for cranked engine black or cylinder head. Inspect for a sticking fuel injector and/or leaking fuel regulator.
	Broken timing chain and/or timing chain gears.	<ol style="list-style-type: none"> Inspect timing chain and gears. Repair as required.
	Material cylinder <ul style="list-style-type: none"> Broken valve Piston material Foreign meterial 	<ol style="list-style-type: none"> Inspect cylinder for damaged components and/or foreign materials. Repair or replace as required.
	Seized crankshaft or connecting rod bearings.	<ol style="list-style-type: none"> Inspect crankshaft and connecting rod bearing. Repair as required.
	Bent or broken connecting rod.	<ol style="list-style-type: none"> Inspect connectong rods. Repair as required.
	Broken crankshaft	<ol style="list-style-type: none"> Inspect crankshaft. Repair as required.

دیجیتال خودرو
شرکت دیجیتال خودرو سامانه (مسئولیت محدود)

اولین سامانه دیجیتال تعمیرکاران خودرو در ایران

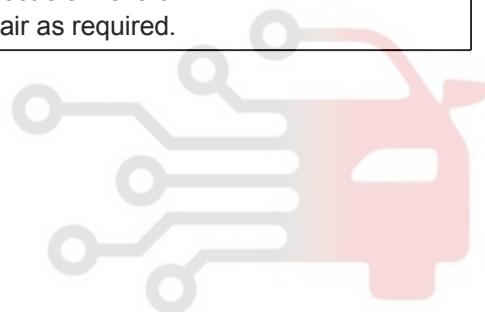

General Information

EM-13

Speical Service Tools

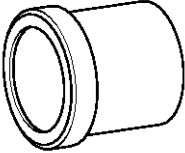
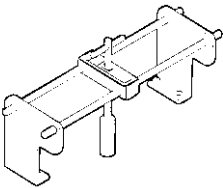
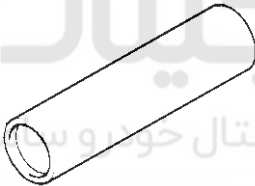
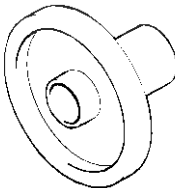
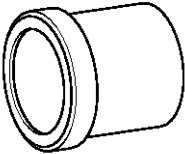
Tool (Number and name)	Illustration	Use
Camshaft oil seal installer (09212-27100)	 <p style="text-align: center;">ACIE003A</p>	Installation of the camshaft oil seal
Valve spring compressor (09222-27300)	 <p style="text-align: center;">ACIE004A</p>	Removal and installation of intake and exhaust valves
Valve stem oil seal installer (09222-27200)	 <p style="text-align: center;">ACIE005A</p>	Installation of valve stem oil seals
Crankshaft rear oil seal installer (09231-27000)	 <p style="text-align: center;">ACIE006A</p>	Installation of the crankshaft rear oil seal
Front case oil seal installer (09231-27100)	 <p style="text-align: center;">ACIE003A</p>	Installation of the front case oil seal

EM-14

Engine Mechanical System

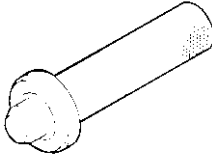
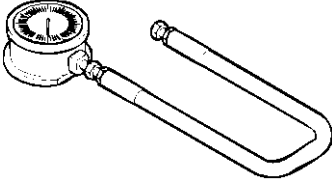
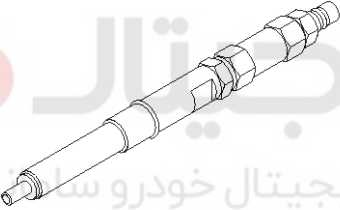
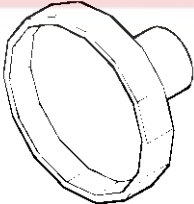
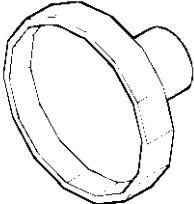
Tool (Number and name)	Illustration	Use
Injector oil seal installer (09351-27401)	 <p style="text-align: center;">ACIE007A</p>	Installation of the injector oil seal
Compression gauge (09351-27000)	 <p style="text-align: center;">SCMEM7001L</p>	Checking engine compression pressure
Compression gauge adapter (09351-27500)	 <p style="text-align: center;">LCGF060A</p>	Checking engine compression pressure
Oil filter wrench (09263-2E000)	 <p style="text-align: center;">ACIE008A</p>	Removal and installation of ECO type oil filter
Oil filter wrench (09263-27000)	 <p style="text-align: center;">ACIE008A</p>	Removal and installation of spin on type oil filter

Engine And Transaxle Assembly

EM-15

Engine And Transaxle Assembly

Removal

⚠ CAUTION

- Make sure jacks and safety stands are placed properly.
- Make sure the vehicle will not roll off stands and fall while you are working under it.
- Use fender covers to avoid damaging painted surface.
- Uplug the wiring connectors carefully while holding the connector portion to avoid damage.
- Mark all wiring and hoses to avoid misconnection.

Also, be sure that they do not contact other wiring or hoses or interfere with other parts.

1. Remove the engine cover.
2. remove the air duct(A).

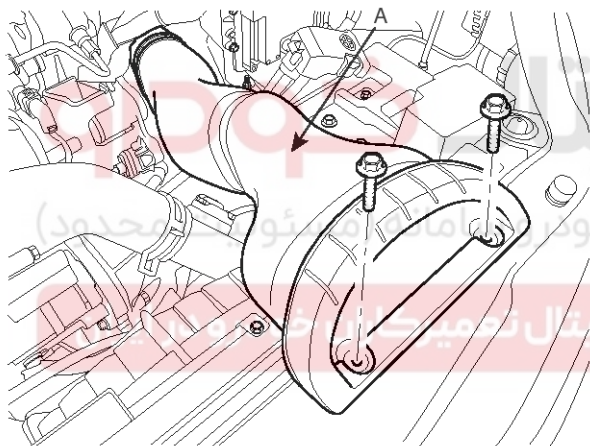

SMGMT6101D

3. Disconnect the battery negative terminal first, then the positive terminal. Remove the battery(A).

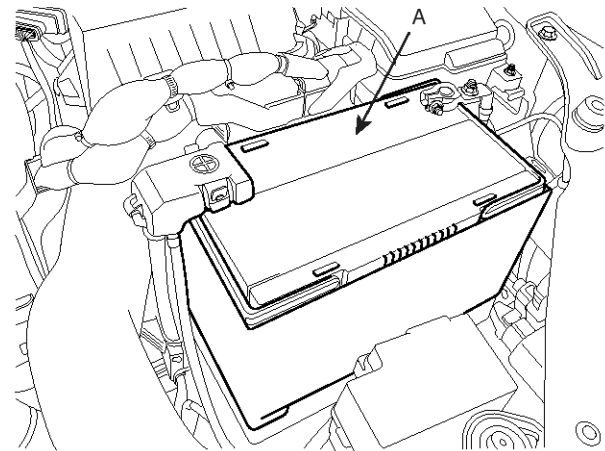

SMGMT6100D

4. Remove the under cover.
5. Drain the engine coolant after removing drain plug(A).
Remove the radiator cap to speed draining.
6. Remove the air cleaner.
 - a. Disconnect the air flow sensor (AFS) connect(A).
 - b. Remove the air intake hose clamp first, then remove the air cleaner assembly(B).
 - c. Remove the air clear assembly(C).

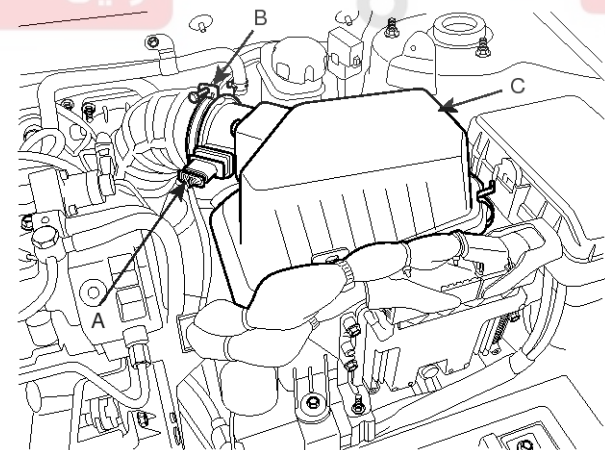

SMGMT6102D

EM-16

Engine Mechanical System

7. Remove the PCM(A).

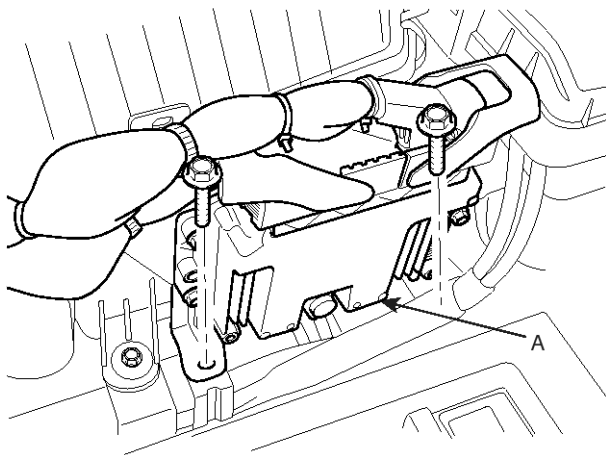

SMGMT6103D

8. Remove the battery tray(A).

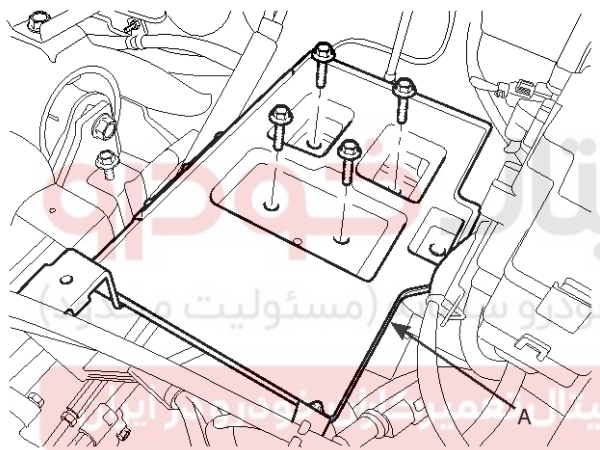

SMGMT6104D

9. Remove the intercooler intake hose(A).

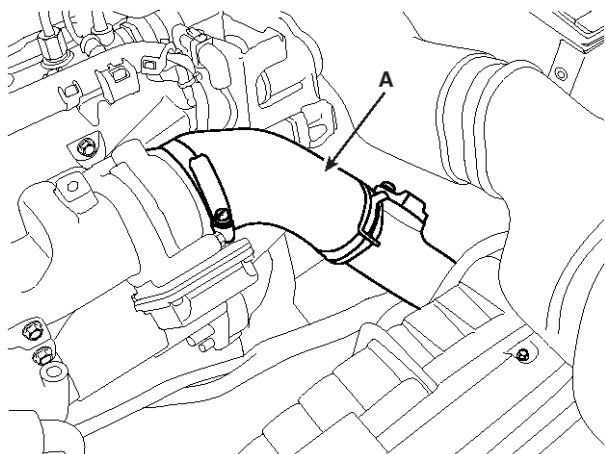

SMGEM6008D

10. Disconnect the engine wire harness connectors.

a. After disconnect the cable, remove the relay and fuses connector by pulling lever(A).

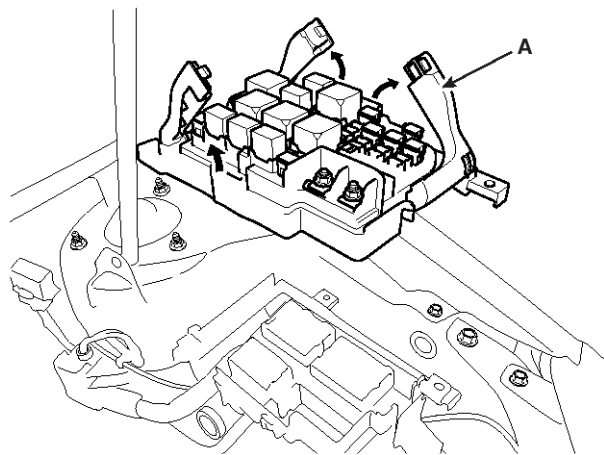

SMGEM6018D

b. Remove the relay & fuse connector cable and ground.

c. Disconnect the solenoid valve vacuum hose(A) and Disconnect the ground cable(B) from cylinder head.

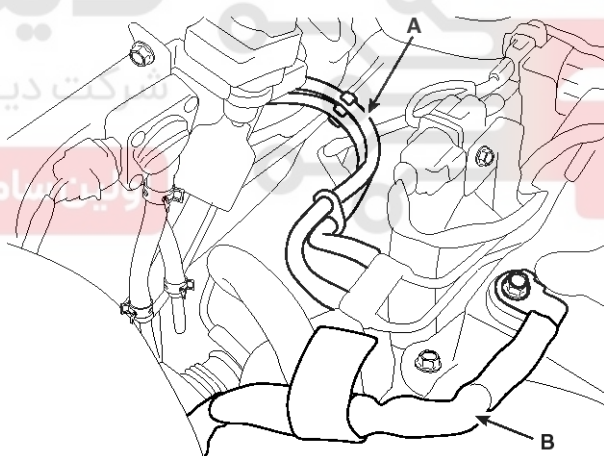

SMGEM6019D

Engine And Transaxle Assembly

EM-17

11. Disconnect the fuel hoses(A) and fuel temperature sensor connector(B).

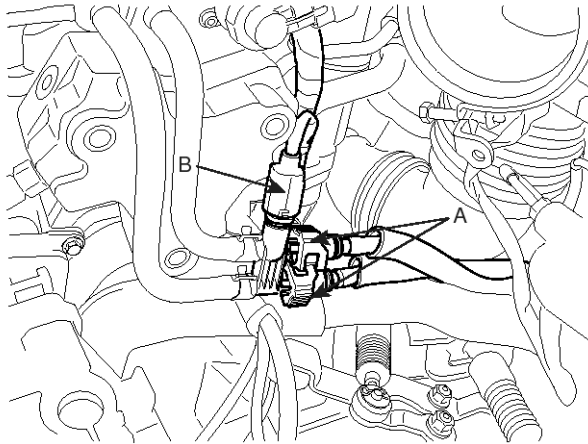

LCIG007A

12. Disconnect the brake booster vacuum hose(A) and heater hose(B).

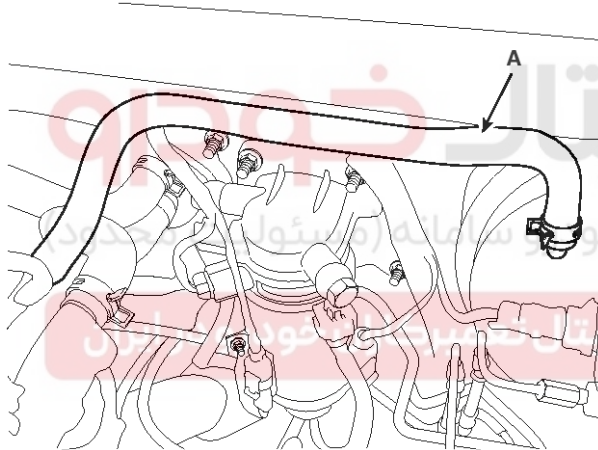

SMGM19022L

13. Remove the heater hose(A) and EGR cooler(B).

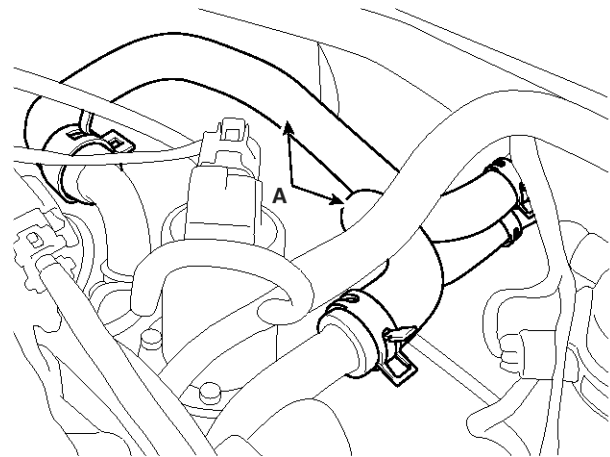

SMGEM6017D

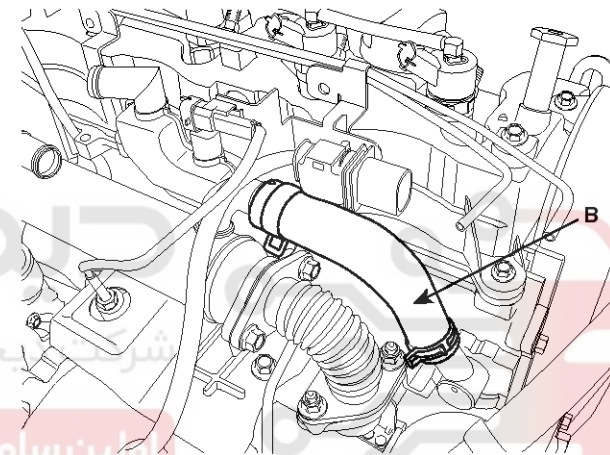

SMGEM6310D

EM-18

Engine Mechanical System

14. Remove the radiator upper hoses(A) and the lower hose(B).

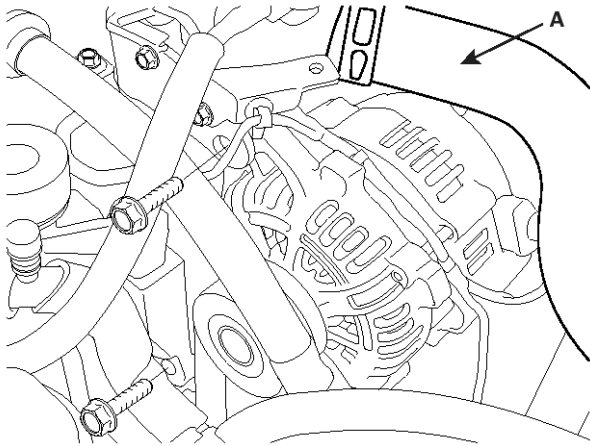

SMGEM6311D

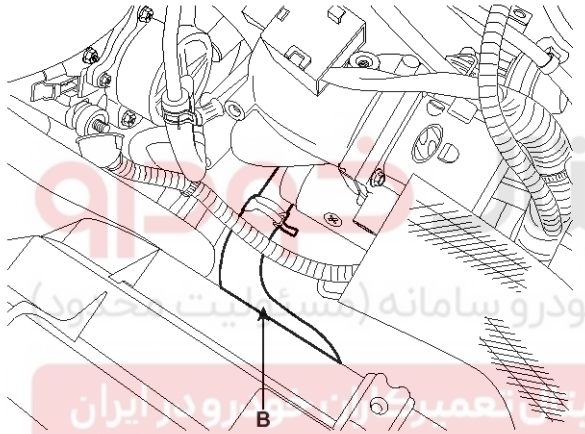

ACIE023A

15. Disconnect the transaxle wire harness and the control cable. (See ST group)

16. After drain the power steering oil, disconnect pump hose and return hose(A). (See ST group)

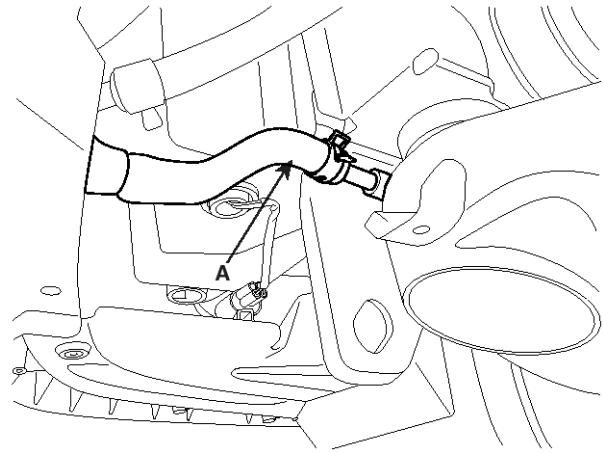

SMGEM6320D

17. Recovering refrigerant and remove the high & low pressure pipe. (See HA group - air conditioner compressor)

18. Remove the steering column joint mounting bolts. (See ST group)

19. Remove the front tires.

20. Remove the stabilizer bar link nut and the lower arm, axle mounting bolt. (See SS group)

21. Remove the front muffler(A).

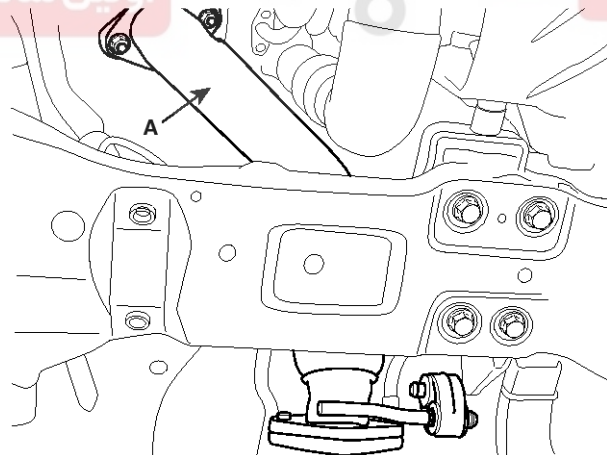

SMGEM6002D

Engine And Transaxle Assembly

EM-19

22. Install the jack for supporting engine and transaxle assembly.

23. Remove the engine mounting bracket(A).

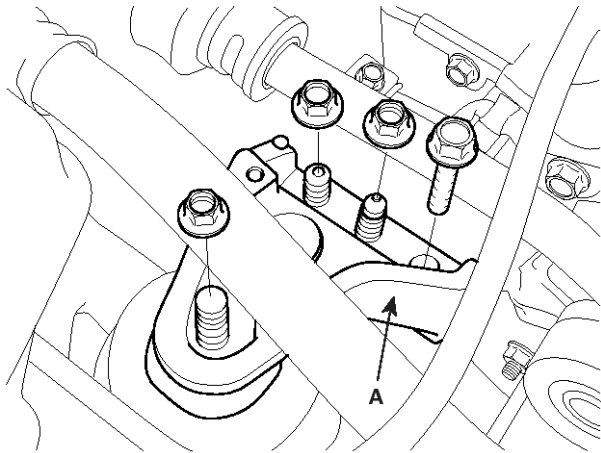

SMGEM6001D

24. Remove the transaxle mounting bracket(A).

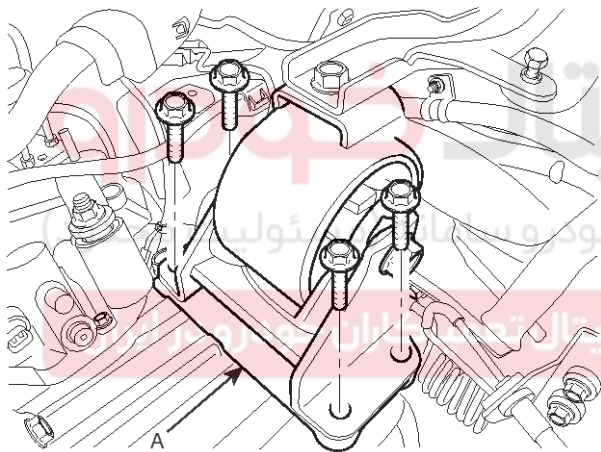

SMGMT6108D

25. Remove the sub frame mounting bolts and nut.

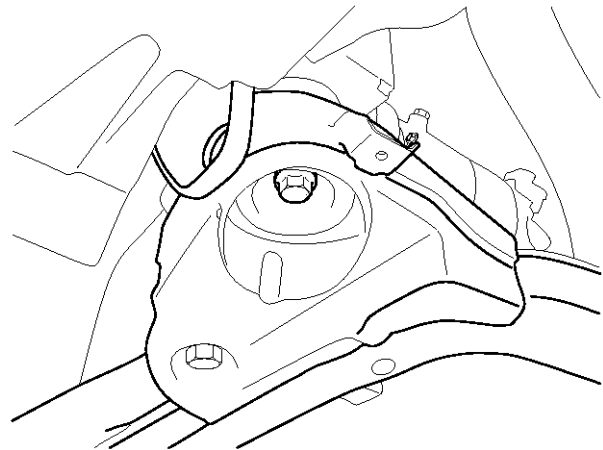

SMGEM6020D

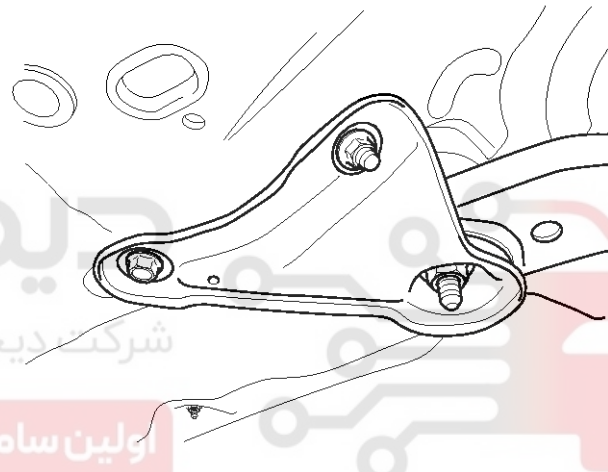

SMGEM6021D

26. Remove the engine and transaxle assembly by lifting vehicle.

NOTICE

When remove the engine and transaxle assembly, be careful not to damage any surrounding parts or body components.

EM-20

Engine Mechanical System

Installation

Install the engine in the reverse order of removal.

Reinstall the mount bolts/nuts in the following sequence.

Failure to follow these procedures may cause excessive noise and vibration, and reduce bushing life.

1. Install the sub frame installation bolt.
2. Tighten the engine and transmission mounting bolts.
3. Connect the power steering oil hoses.
4. Install the front muffler.
5. Install the front tires/wheels and splash shield.
6. Connect the air condition hoses.
7. Install the transmission links.
8. Connect the fuel hoses.
9. Connect the engine wire harness connectors.
10. Connect the radiator upper and lower hoses.
11. Connect the heater hoses.
12. Connect the hose to the reservoir tank.
13. Connect the intercooler hoses.
14. Install the air cleaner and the battery.
15. Perform the following :
 - Clean the areas where the driveshaft contact the transmission thoroughly with solvent or carburetor cleaner, and dry with compressed air.
 - Check that the snap rings on the ends of the driveshaft click into place.



Timing System

EM-21

Timing System

Components

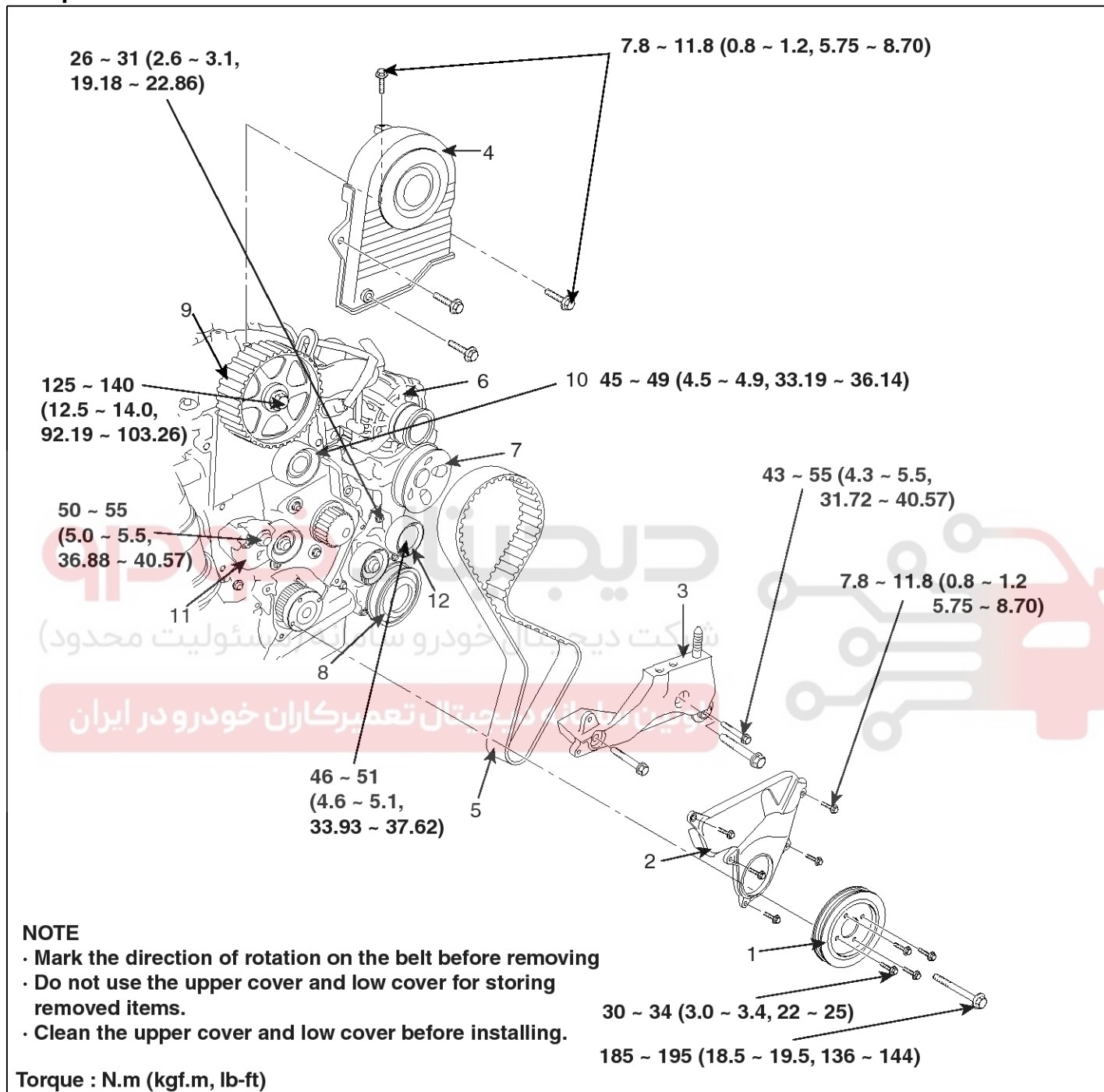

SMGM19010L

- | | | |
|----------------------------|--|---------------------------|
| 1. Damper pulley | 5. Timing belt | 9. Camshaft sprocket |
| 2. Timing belt lower cover | 6. Alternator and vacuum pump assembly | 10. Timing belt idler |
| 3. Engine support bracket | 7. Power steering pump | 11. Timing belt tensioner |
| 4. Timing belt upper cover | 8. Air conditioning compressor | 12. Idler |

EM-22

Engine Mechanical System

Removal

1. Remove the front tires.(RH)
2. Remove the side cover.
3. The tensioner should be lifted up to remove the drive belt(A).

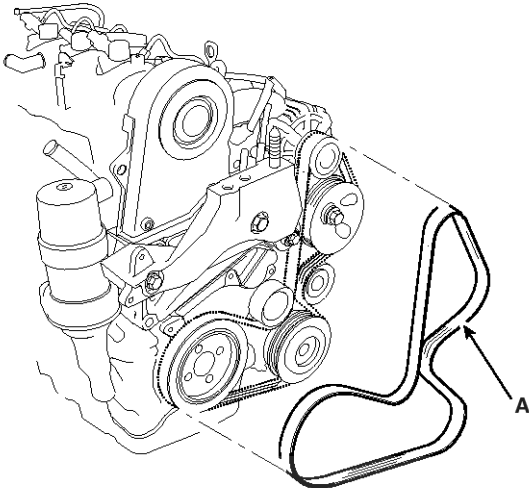

SCMEM6030D

4. Remove the engine mounting bracket.

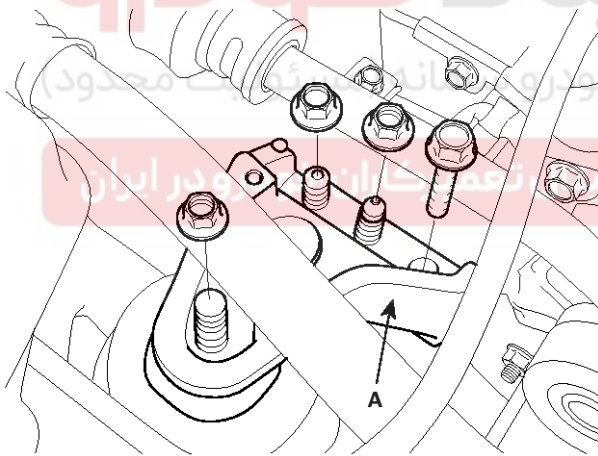

SMGEM6001D

5. Remove the timing belt upper cover(A).

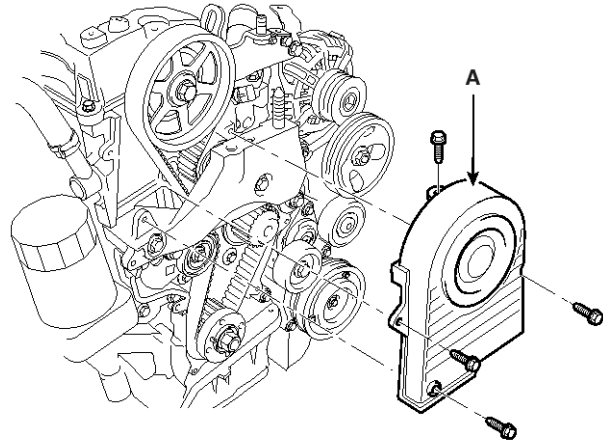

SCMEM6033D

6. Remove the crankshaft(A).

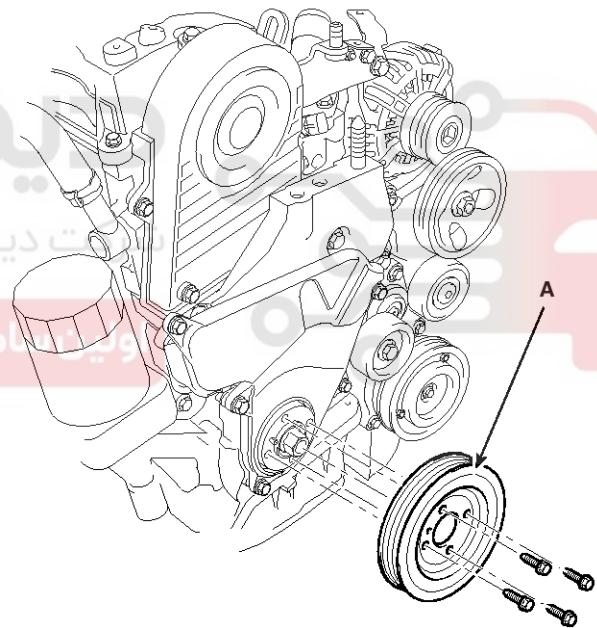

SCMEM6031D

Timing System

EM-23

7. Remove the timing belt lower cover(A).

NOTICE

If remove the tensioner, easy the working ability.

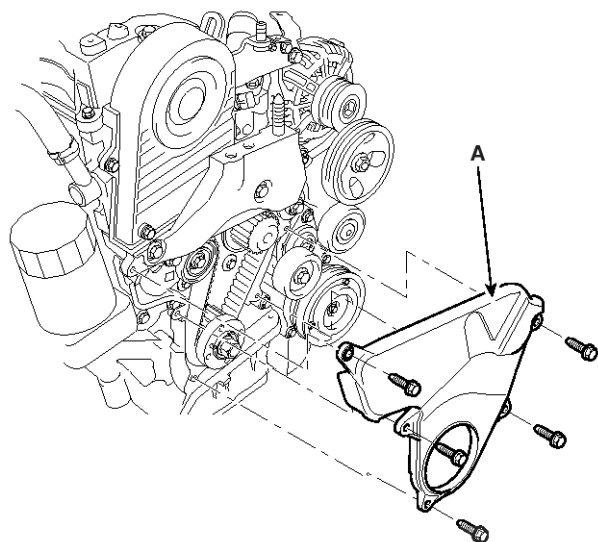

SCMEM6032D

8. Remove the engine support bracket(A).

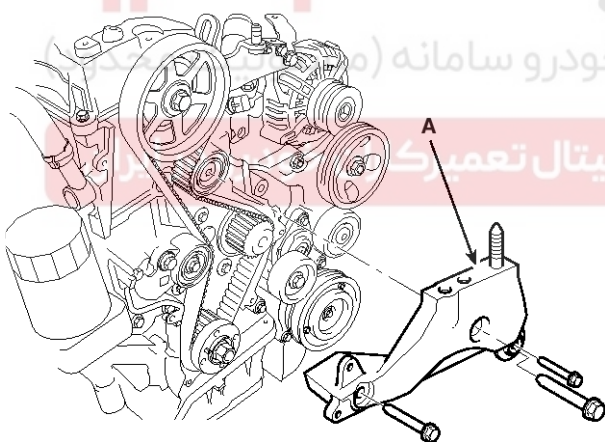

SCMEM6034D

9. Align the timing marks(A, B) on the camshaft sprocket(C) and the crankshaft sprocket(D) with the marks(E, F) on the cylinder head(G) and the oil pump case(H) with rotating the engine.

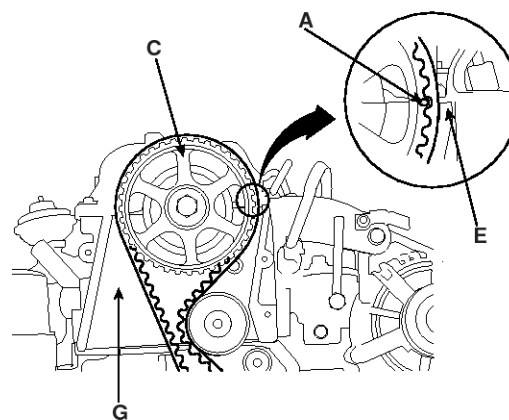

LCIF011A

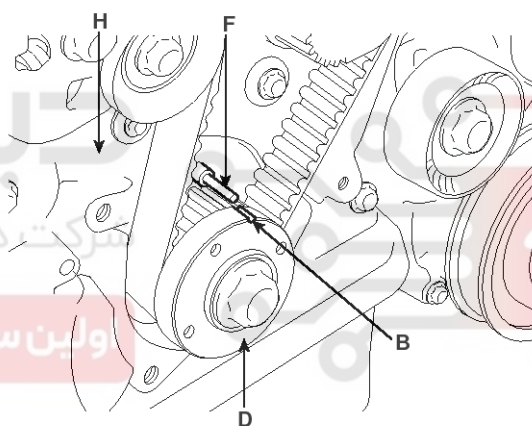

LCIF012A

EM-24

Engine Mechanical System

10. Insert a pin(A) into the aligned holes in the auto-tensioner(B).

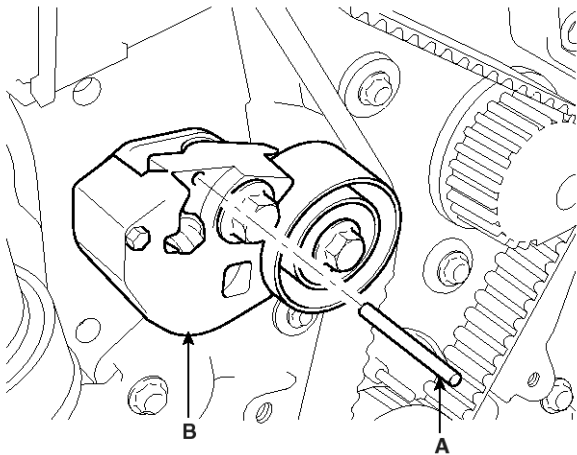

EDKD536A

11. Using a hexagonal wrench (5mm)(A), loosen the stop bolt(B). And then, turning the auto-tensioner(C) clockwise fully with the boss bolt(D) and 12mm spanner(E), retighten the stop bolt(B).

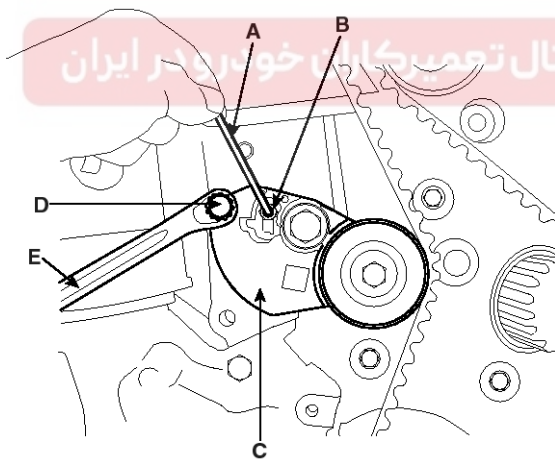

EDKD537A

12. Remove the timing belt.

NOTICE

To be prepared in case the removed belt is used, mark an arrow on the timing belt in the direction of rotation before removing it.

Inspection

1. Remove the upper cover.
2. Inspect the timing belt(A) for cracks and oil or coolant soaking.

NOTICE

- Replace the belt if oil or coolant soaked.
- Remove any oil or solvent that gets on the belt.

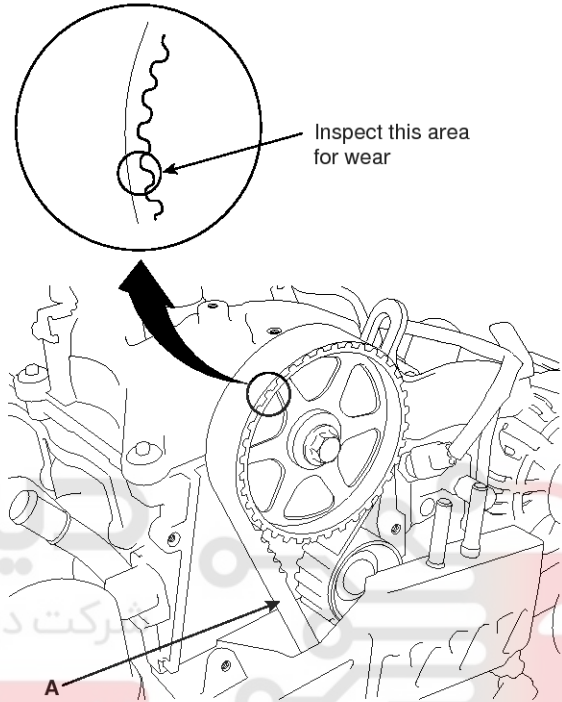

EDKD541A

Sprockets, Tensioner, Idler

1. Check the camshaft sprocket.
Camshaft sprocket, crankshaft, tensioner pulley and idler pulley for abnormal wear, cracks or damage. Replace as necessary.
2. Inspect the tensioner pulley and the idler pulley for easy and smooth rotation and check for play or noise. Replace as necessary.
3. Replace the pulley if there is a grease leak from its bearing.

Timing System

EM-25

Installation

1. Align the timing mark(A) on the camshaft sprocket(B) with the mark(C) on the cylinder head(D).

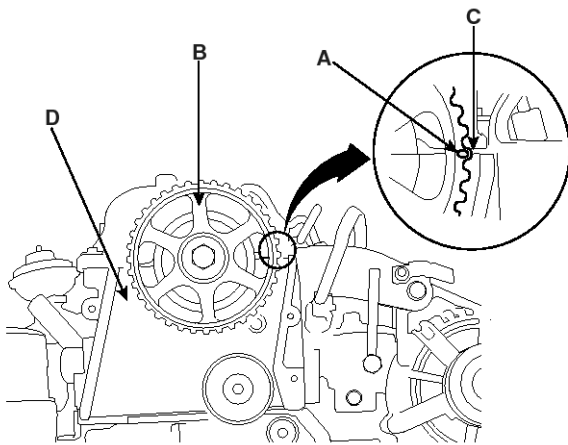

ACIE051A

2. Align the timing mark(A) on the crankshaft sprocket(B) with the pin(C) press fitted in the oil pump housing(D).

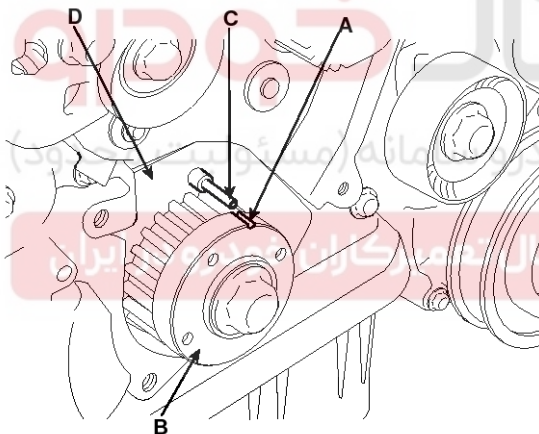

ACIE052A

3. Install the timing belt.

- a. Install the timing belt(A) tightly in the sequence shown.

- ① Timing belt drive pulley(B) (crankshaft) → ② Water pump pulley(C) ③ Timing belt idler(D) → ①
- ④ Camshaft sprocket(E) → ⑤ Timing belt tensioner(F).

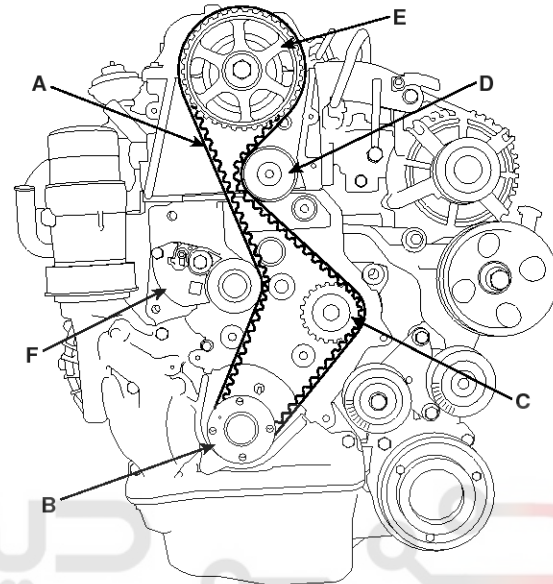

ACIE053A

- b. Turn the auto-tensioner(C) counterclockwise fully to install the timing belt using the boss bolt(D) and spanner(E).

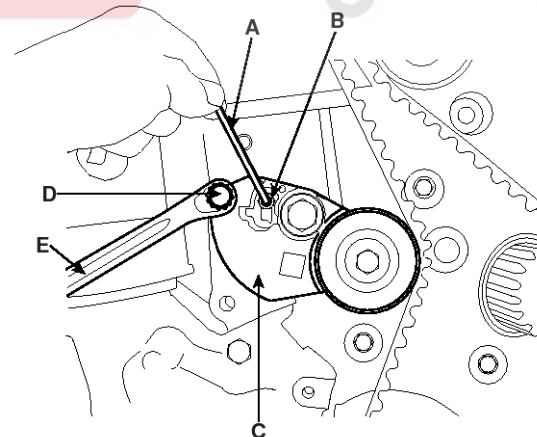

ACIE050A

EM-26

Engine Mechanical System

- c. Rotate the crankshaft by hand 2 complete revolutions (clockwise) to take up any slack and set to TDC(Top Dead Center).
- d. Using a hexagonal wrench, install the stop bolt.

Tightening torque :

10 ~ 12N.m (1.0 ~ 1.2 kgf.m, 7 ~ 9lb-ft)

- e. Remove the fixing pin(A)

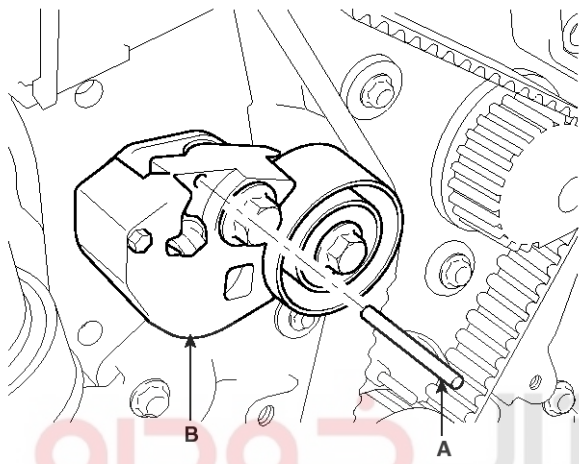

EDKD536A

- 4. Install the engine support basket(A).

Tightening torque :

43 ~ 55N.m (4.3 ~ 5.5kgf.m, 31.72 ~ 40.57lb-ft)

- 5. Install the timing belt upper cover(A) and lower cover(B).

Tightening torque :

7.8 ~ 11.8N.m (7.8 ~ 11.8kgf.m, 5.75 ~ 8.70lb-ft)

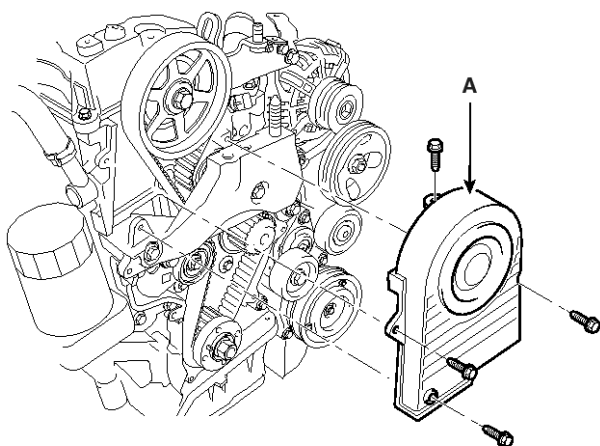

SCMEM6033D

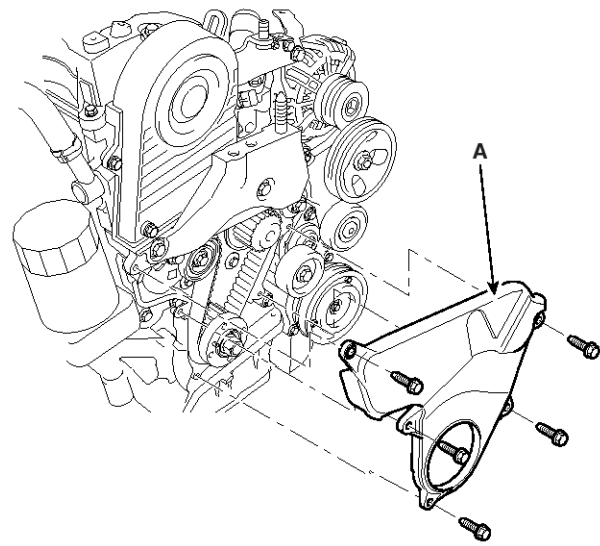

SCMEM6032D

- 6. Install the crankshaft pulley(A).

Tightening torque :

30 ~ 34N.m (3.0 ~ 3.4kgf.m, 22 ~ 25lb-ft)

- 7. Install the engine mounting bracket.
- 8. Install the drive belt(A), following the sequence below.

1.Alternator → 2.Power steering → 3.Idler → 4.Air compressor → 5.Crankshaft pulley → 6.Tensioner.

The tensioner should be lifted up to install the drive belt(A).

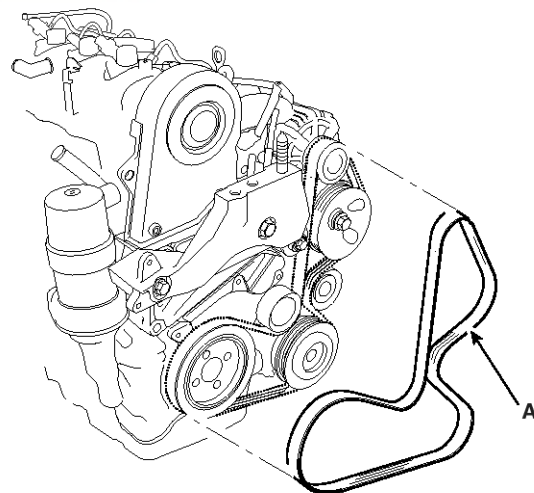

SCMEM6030D

- 9. The tensioner should be lifted up to install the drive belt(A).
- 10. Install the front tires.(RH)

Cylinder Head Assembly

EM-27

Cylinder Head Assembly

Components

CAUTION

- To avoid damage, wait until the engine coolant temperature drops before removing cylinder head.
- When handling a metal gasket, take care not to fold damage the contact surface.

8 ~ 10 (0.8 ~ 1.0, 5.90 ~ 7.38)

50 (5.0, 38.9) + 120° + 120°

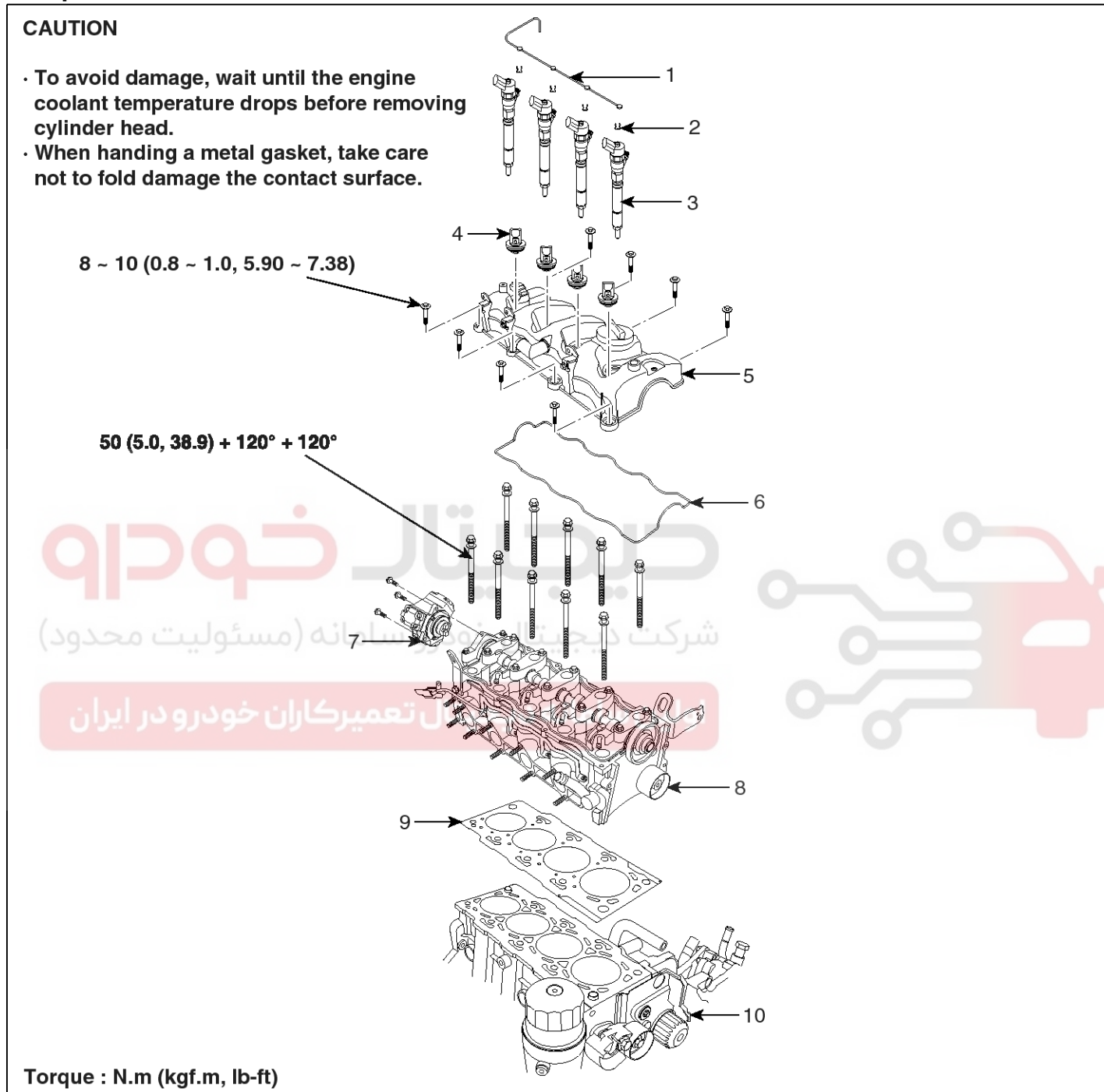

Torque : N.m (kgf.m, lb-ft)

SMGM19011L

- | | | |
|-------------------------------|-------------------------------|-----------------------------|
| 1. Fuel return hose | 5. Cylinder head cover | 8. Cylinder head |
| 2. Cilp | 6. Cylinder head cover gasket | 9. Cylinder head gasket |
| 3. Injector | 7. Fuel pump | 10. Cylinder block assembly |
| 4. Injector installation plug | | |

EM-28

Engine Mechanical System

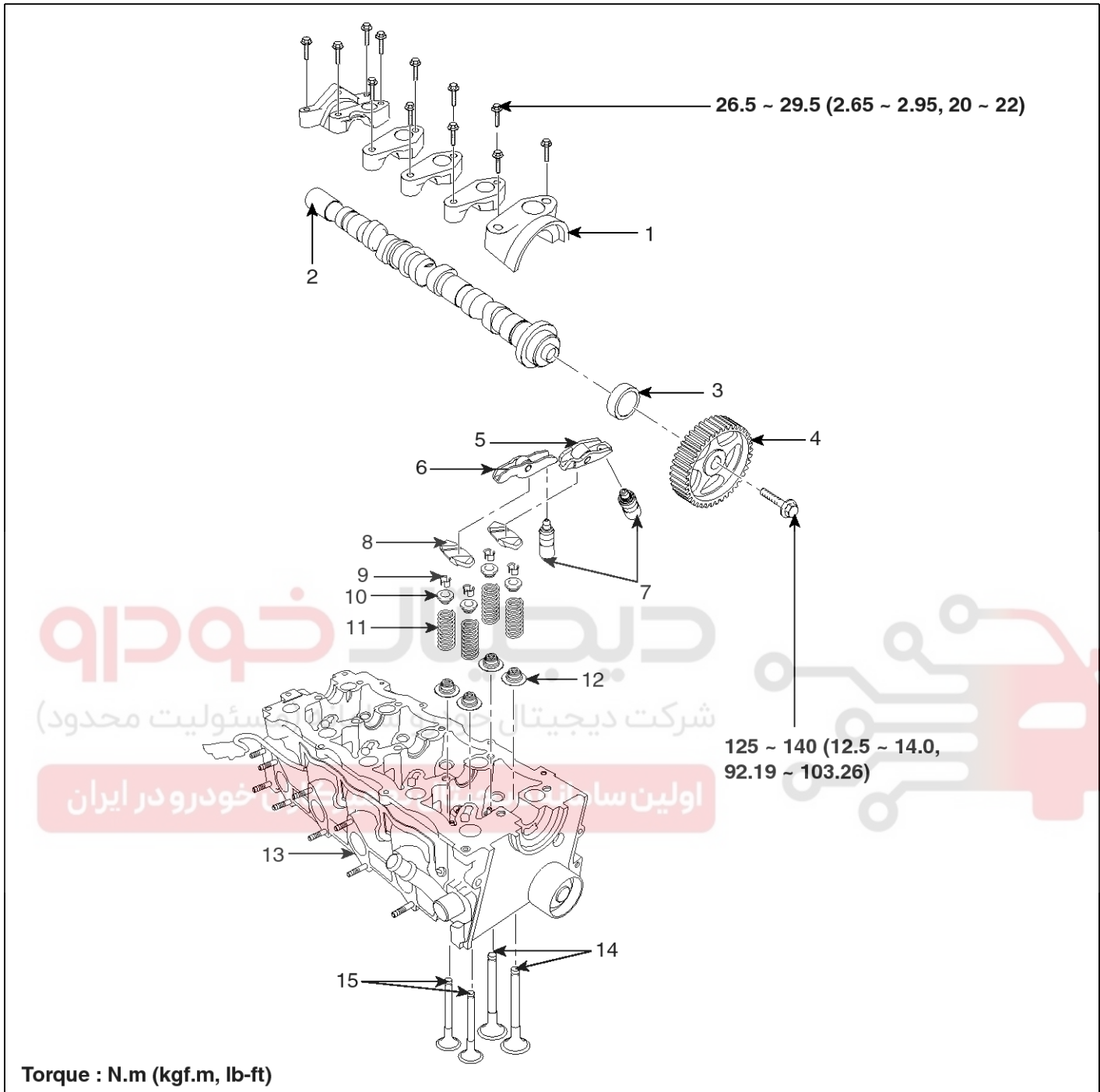

SMGM19012LL

- 1. Camshaft bearing cap
- 2. Camshaft
- 3. Oil seal
- 4. Camshaft sprocket
- 5. Intake cam follower

- 6. Exhaust cam follower
- 7. Lash adjuster
- 8. Valve cap
- 9. Valve spring retainer lock
- 10. Valve spring retainer

- 11. Valve spring
- 12. Valve stem seal
- 13. Cylinder head
- 14. Intake valves
- 15. Exhaust valves

Cylinder Head Assembly

EM-29

Removal

1. Before removing the cylinder head, the timing belt should be removed first. Refer to the timing belt 'removal' step.
2. Disconnect the fuel return hose after removing the clips(A).

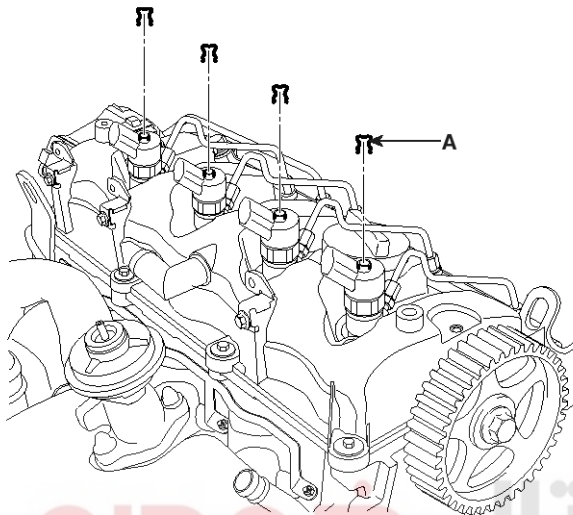

EDKD545A

3. Remove the fuel tube. (See FL- groud- fuel pump)
4. Remove the connector.
5. Remove the plugs(A).
 - a. Pull the plug up slightly. (more than 1mm)
 - b. Rotate the plug 90° clockwise.
 - c. Remove the plug with inserting a (-)driver between the plug assy(B) and the cylinder head cover(C).

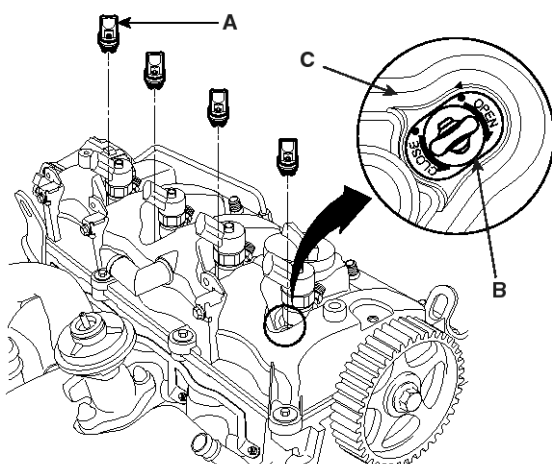

KCQG005A

6. Remove the injector holder bolt using the torx wrench.

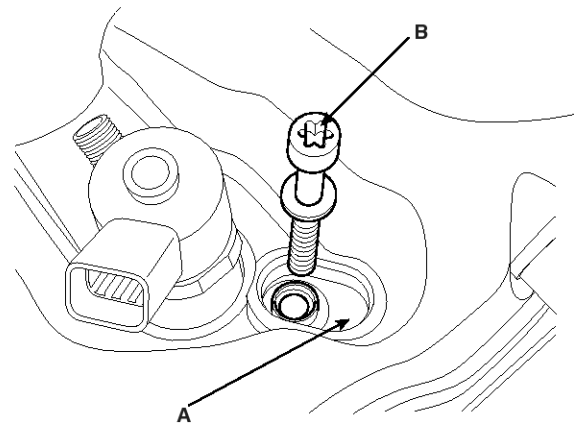

EDKD548A

7. Pull the injector holders with the bolts.
8. Remove the injectors(A).



EDKD549A

- a. Disconnect the position sensor.
- b. Remove the wiring bracket.
- c. Remove the pipe between the oil pan.
- d. Remove the fuelline hose bolt.

EM-30

Engine Mechanical System

9. Remove the cylinder head cover mounting bolts(A,B).

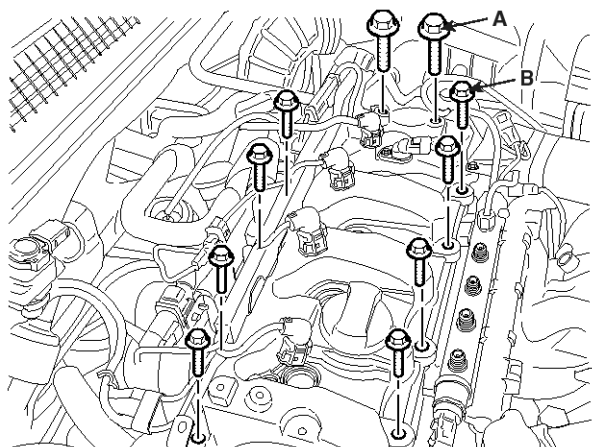

SNFEM6006D

10. Remove the cylinder head cover.

11. Remove the injector holders(A) with the bolts(B).

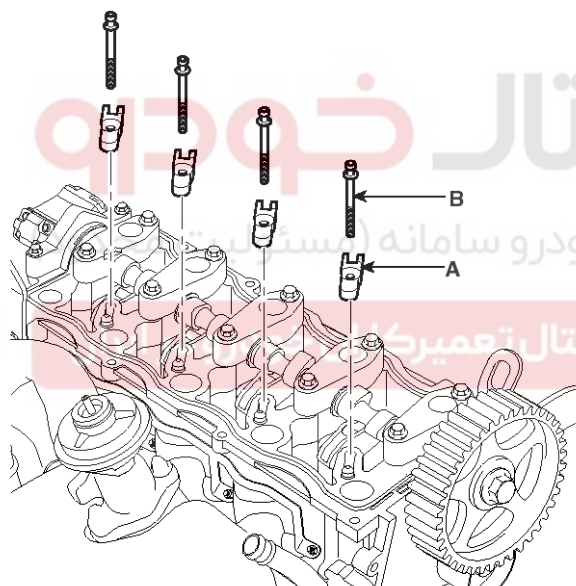

EDKD552A

12. Remove the metal tube(A) between the fuel pump(B) and the common rail(C).

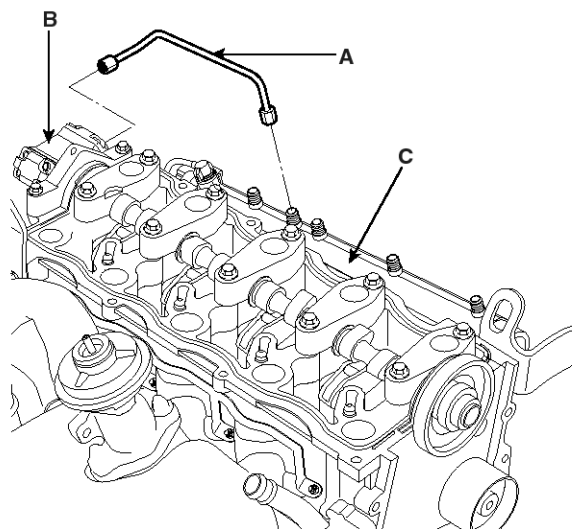

EDKD554A

13. Remove the fuel pump(A) after removing the three bolts(B).

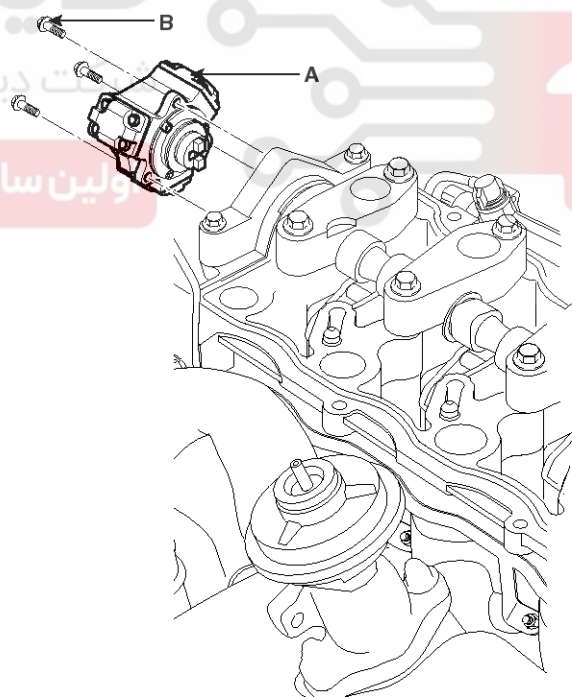

EDKD555A

Cylinder Head Assembly

EM-31

14. Remove the exhaust manifold.
15. Remove the intake manifold.
16. Remove the cylinder head bolts(A), then remove the cylinder head(B).

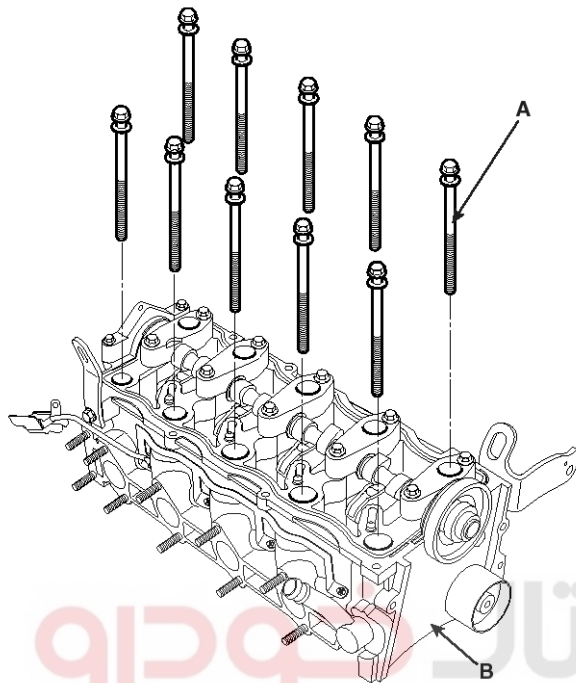

EDKD556A

CAUTION

To prevent warpage, unscrew the bolts in science 1/3 turn at a time:repeat the sequence until all bolts are loosened.

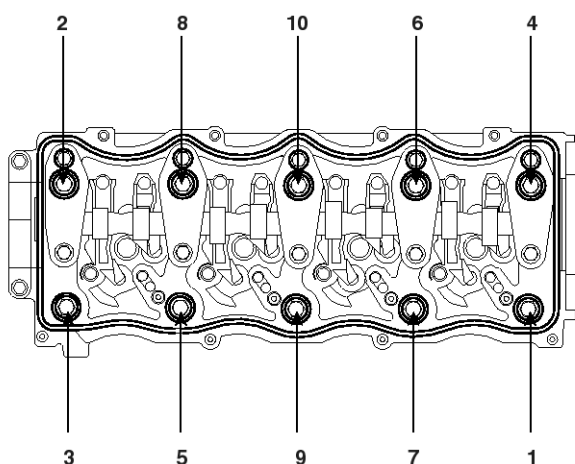

EDKD557A

Disassembly

NOTICE

- Identify parts as they are removed to ensure reinstallation in original locations.
 - Inspect camshafts.
1. Remove the engine hangers, the knock bushes and the studs.
 2. Remove the camshaft bearing caps(A).

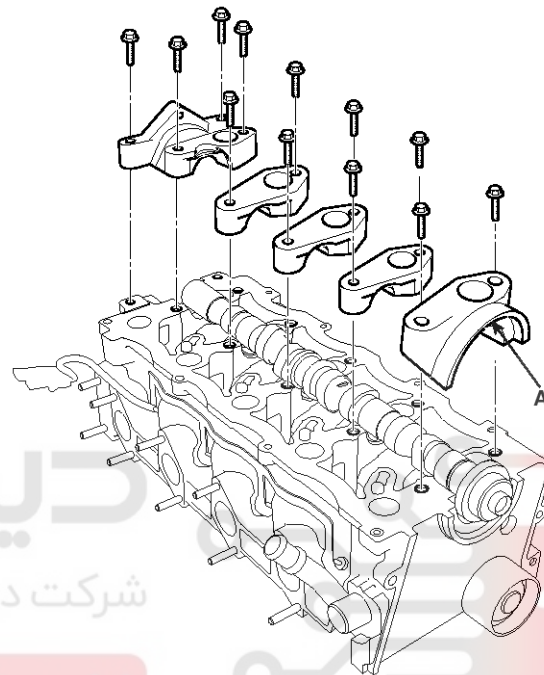

ACIE068A

3. Remove the camshaft(A) with the oil seal(B).

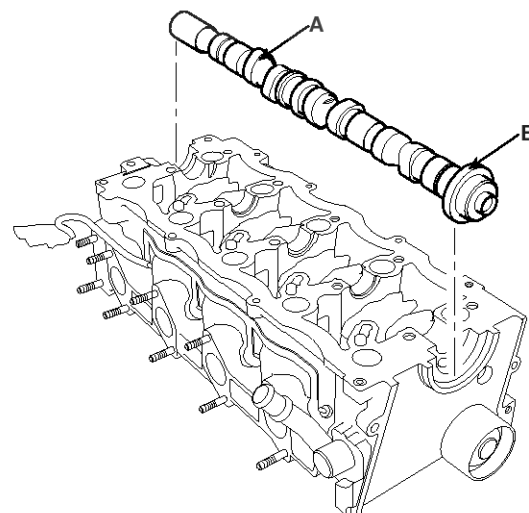

ACIE069A

EM-32

Engine Mechanical System

4. Remove the Intake/Exhaust cam followers(A, B).

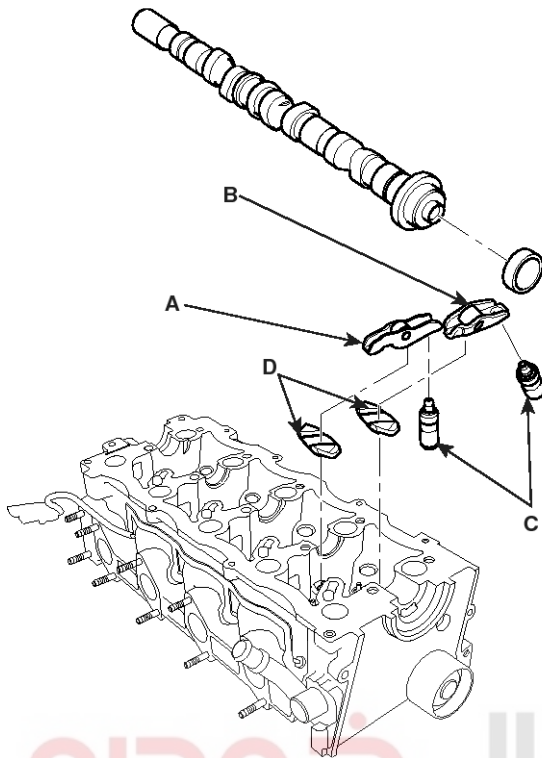

ACIE070A

5. Remove the lash adjusters(C).
 6. Remove the valve caps(D).
 7. Using an appropriate-sized socket and plastic mallet, lightly tap the valve retainer to loosen the valve retainer locks before installing the valve spring compressor.

NOTICE

Identify valves and valve springs as they are removed so that each item can be reinstalled in its original position.

8. Using the SST(09222-27300), compress the valve spring(A) in order to remove the valve spring retainer locks(B).

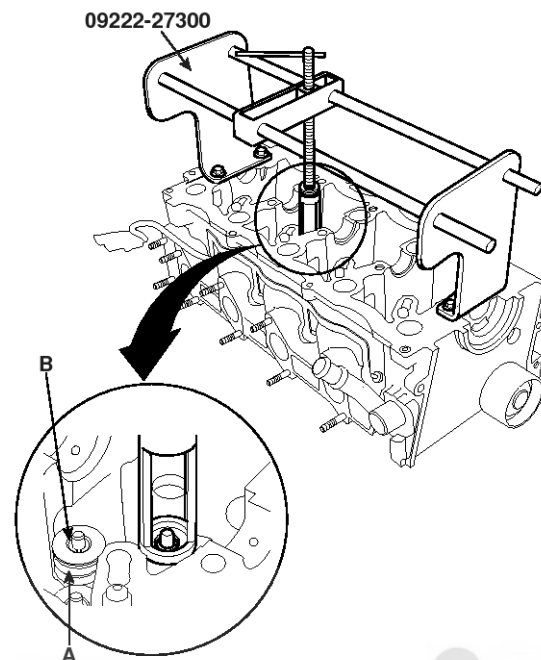

ACIE071A

9. Remove the valve stem seals(A).

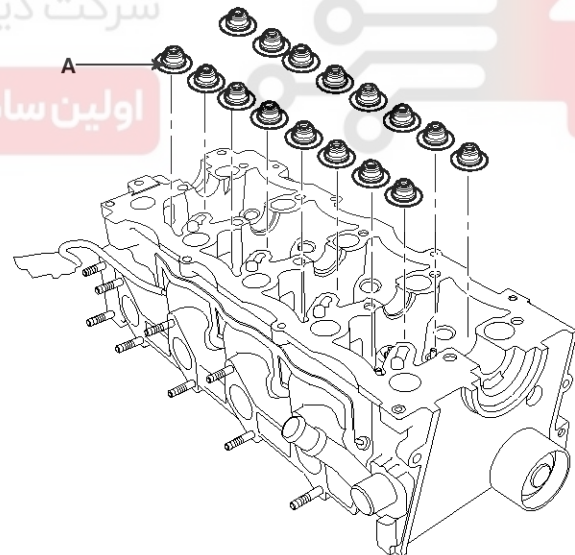

ACIE072A

Cylinder Head Assembly

EM-33

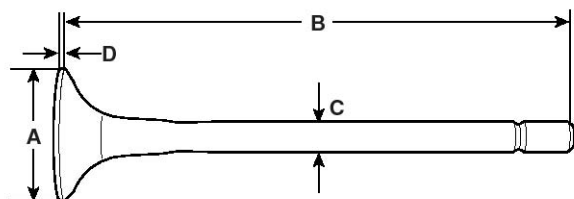

LCIF019A

Intake Valve Dimensions

- A Standard (New) :
28.5 ~ 28.7mm (1.1220 ~ 1.1299in.)
- B Standard (New) :
94.0 ~ 94.2mm (3.7008 ~ 3.7087in.)
- C Standard (New) :
5.933~5.953mm (0.2336~0.0669in.)
- D Standard (New) :
1.5 ~ 1.7mm (0.0591 ~ 0.0669in.)

Exhaust Valve Dimensions

- A Standard (New) :
24.3 ~ 24.5mm (0.9567 ~ 0.9646in.)
- B Standard (New) :
94.0 ~ 94.2mm (3.7008 ~ 3.7087in.)
- C Standard (New) :
5.905~5.925mm (0.2325~0.2333in.)
- D Standard (New) :
1.2 ~ 1.4mm (0.0472 ~ 0.0551in.)

Inspection

Camshaft

NOTICE

Do not rotate the camshaft during inspection.

1. Put the camshaft(A) and the camshaft bearing caps(B) on the cylinder head(C), then tighten the bolts to the specified torque with the following sequence below.

Specified torque

26.5 ~ 29.5N.m (265 ~ 295kgf.cm, 20 ~ 22lb-ft)

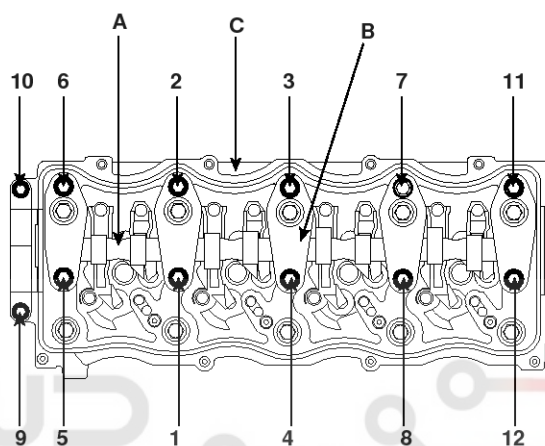

ACIE073A

2. Seat the camshaft by pushing it toward the rear of the cylinder head.
3. Zero the dial indicator(A) against the end of the camshaft(B).

Push the camshaft(B) back and forth, and read the end play.

Camshaft End Play

Standard (New) : 0.05 ~ 0.15mm (0.002 ~ 0.006in.)

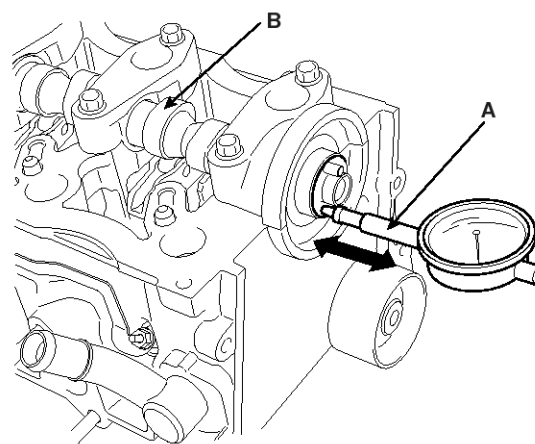

ACIE074A

EM-34

Engine Mechanical System

4. Remove the bolts, then remove the camshaft bearing caps from the cylinder head(A).
 - Lift the camshaft(B) out of the cylinder head(A), wipe it clean. Replace the camshaft if any lobes are pitted, scored, or excessively worn.
 - Clean the camshaft bearing surfaces in the cylinder head, then set the camshaft back in place.
 - Place a plastigauge strip(C) across each journal.
5. Install the camshaft bearing caps and tighten the bolts to the specified torque.
6. Remove the camshaft bearing caps, then measure the widest portion of the plastigauge(C) on each journal.

Camshaft-to-Camshaft bearing cap oil clearance

Standard (New)

0.040 ~ 0.074mm (0.0020 ~ 0.0029in.)

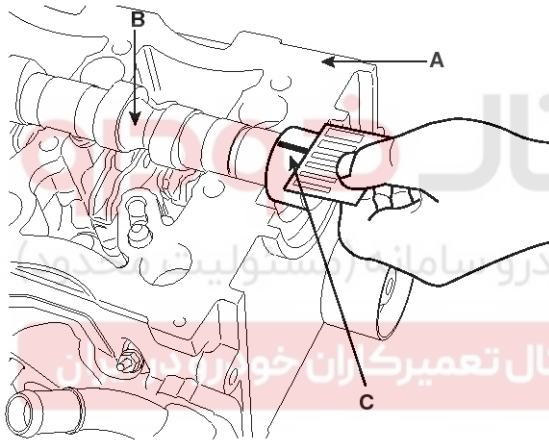

LCIF020A

7. If the camshaft-to-camshaft bearing cap oil clearance is out of tolerance :
 - And the camshaft(A) has already been replaced, you must replace the cylinder head.
 - If the camshaft has not been replaced, first check the total runout with the camshaft supported on V-blocks.

Camshaft Total Runout

Standard (New)

0.035mm (0.0014in.) for No.2 and4

0.050mm (0.0019in.) for No.3

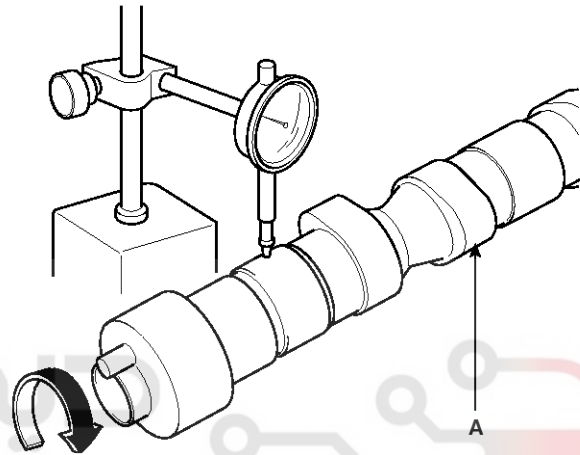

LCIF021A

- If the total runout of the camshaft is within tolerance, replace the cylinder head.
- If the total runout is out of tolerance, replace the camshaft and recheck the camshaft-to-camshaft bearing cap oil clearance. If the oil clearance is still out of tolerance, replace the cylinder head.

Cylinder Head Assembly

EM-35

8. Check the cam height wear.

[Standard]

Intake : 34.697mm (1.366in.)

Exhaust : 34.570mm (1.361in.)

[Limit]

Intake : 34.197mm (1.346in.)

Exhaust : 34.070mm (1.341in.)

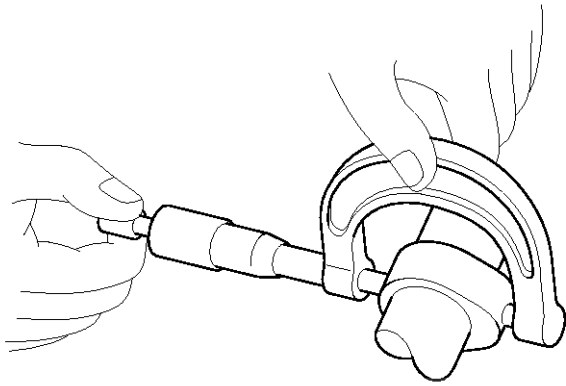

ACIE076A

Warpage

Check the cylinder head(A) for warpage.

- If warpage is less than 0.03mm (0.0012in.) for width, 0.09mm (0.0035in.) for length and 0.012mm (0.0035in) for 51mm ×51mm, cylinder head is in good condition.
- If warpage is over the standard value, replace the cylinder head.

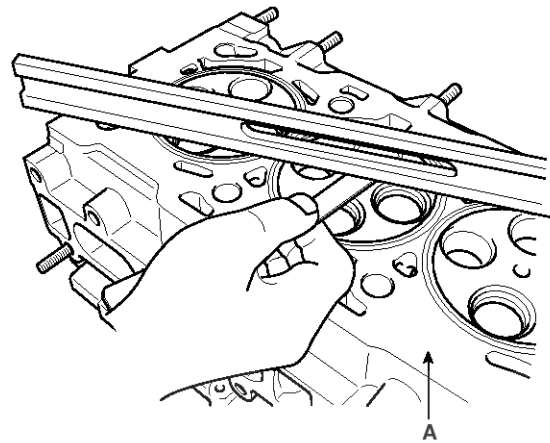

ACIE084A

Measure along edges, and three ways across center.

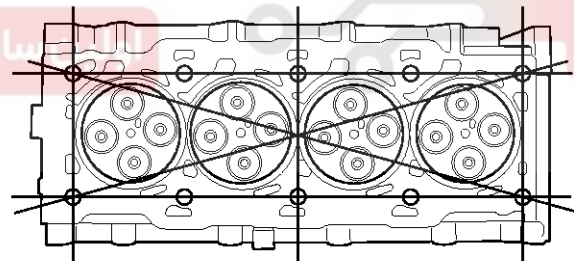

ACIE085A

EM-36

Engine Mechanical System

Reassembly

NOTICE

Prior to reassembling, cylinder head assembly shall be cleaned sufficiently to remove scrap and clust. (Clean holes with special care.)

1. Using the SST(09222-27200) insert the valve stem seals(A).

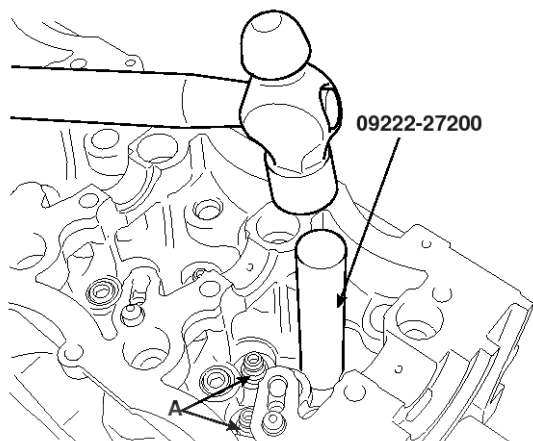

ACIE086A

2. Insert the valves through the valve stem seals.

NOTICE

Make sure the valves move up and down smoothly.

3. Install the valve spring(A) and valve spring retainer(B), then install the SST (09222-27300, the valve spring compressor). Compress the spring(A) and install the valve spring retainer lock(C).

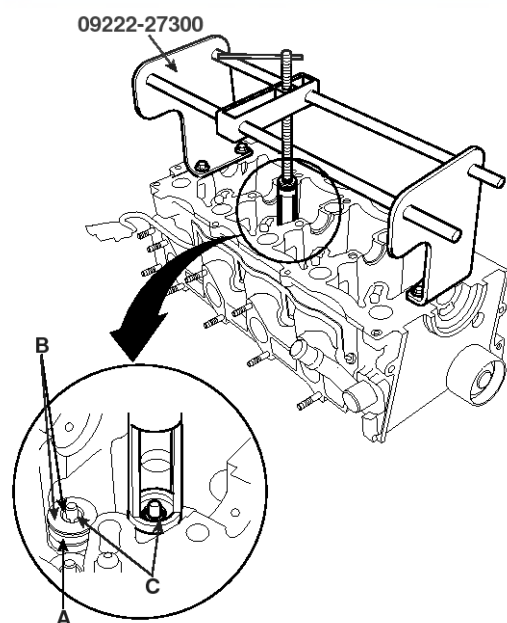

ACIE087A

4. Lightly tap the end of each valve stem two or three times with a plastic mallet to ensure proper seating of the valve and valve spring retainer locks.

NOTICE

Tap the valve stem only along its axis so you do not bend the stem.

5. Assembly of lash adjuster.
 - a. Until installing, lash adjuster shall be held upright so that gas oil in lash adjuster should not spill and assured that dust does not adhere to adjuster.
 - b. Lash adjuster shall be inserted tenderly to the cylinder head not to spill gas oil from lash adjuster. In case of spilling air bent shall be done in accordance with the air bent procedure below.

NOTICE

Air bent procedure

1. In case of lash adjuster alone.

Stroke lash adjuster in gas oil 4~5 times by pushing its cap while pushing the ball down slightly by hard steel wire.

Take care not to severely push hard steel wire down since ball is several grams.

2. After installed on engine

Lash adjuster might give out unusual noise if air is mingled. Apply slow racing from idle to 3,000rpm (Approximately one minute per one racing) and the air shall be removed from adjuster.

Therefore noise can be extinguished.

6. Install the valve-caps.
7. Put the cam followers on the lash adjusters and valve caps.
8. After wiping down the camshaft and camshaft seal in the cylinder head, lubricate both surfaces and install the camshaft with engine oil.
9. Confirm that cam followers are located on lash adjusters and their rollers are in touch with camshaft.
10. In assembly camshaft bearing cap, to the cylinder head with the cylinder block, all pistons should be in the middle position between TDC(Top Dead Center) and BDC(Bottom ead Center) because valves come out of the bottom surface of the cylinder head.

Cylinder Head Assembly

EM-37

11. Install the bolts loosely.
12. Tighten each bolt two turns at a time in the sequence shown below to ensure that the cam followers do not bind on the valves.

Tightening torque

26.5 ~ 29.5N.m (265 ~ 295kgf.m, 20 ~ 22lb-ft)

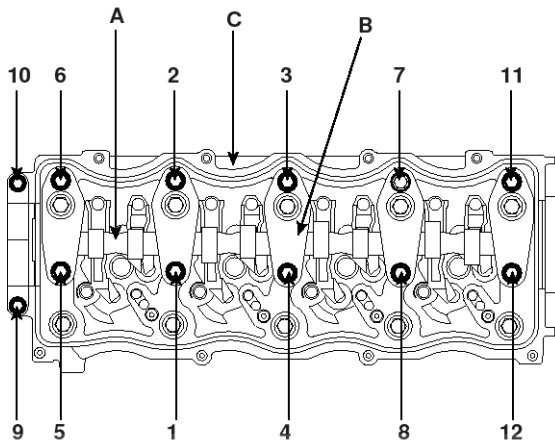

ACIE073A

Installation

Install the cylinder head in the reverse order of removal :

NOTICE

- Always use a new head gasket.
- Cylinder head and cylinder block surface must be clean.
- Turn the crankshaft so the No.1 piston is at TDC(Top Dead Center).

1. Cylinder head dowel pins must be aligned.
2. Select the cylinder head gasket.
 - a. Measure the piston protrusion from the upper cylinder block face (I) on 8 places (A ~ H) at T.D.C. Measure on the crankshaft center line considering the piston migration.

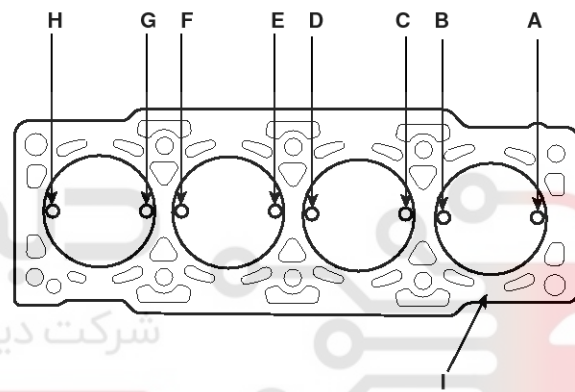

ACIE088A

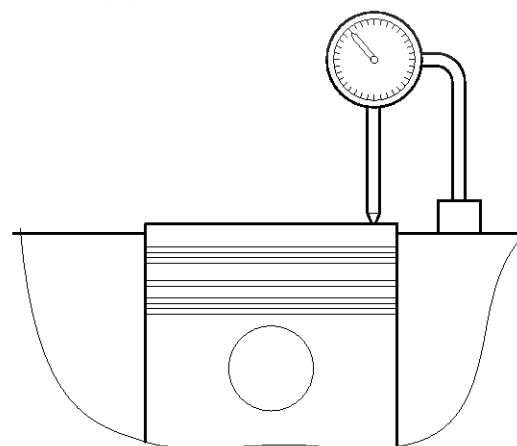

ACIE089A

EM-38

Engine Mechanical System

b. Select the gasket in the table below using the average value of piston protrusions.

Although even the only 1 point is over than the each rank limit, use 1 rank upper gasket than specified in the table below.

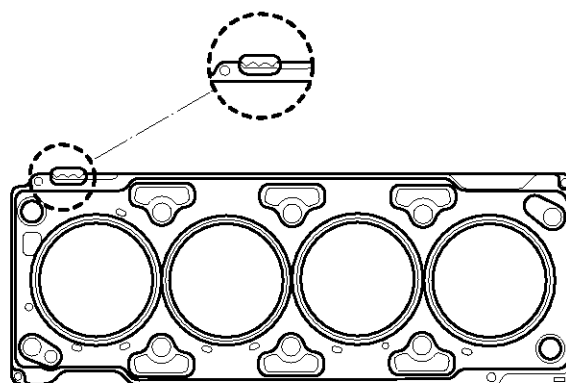

ACIE090A

Displacement	2.0 L		
	Average of piston protrusion	0.194 ~ 0.337mm (0.0079 ~ 0.013in.)	0.337 ~ 0.440mm (0.013 ~ 0.017in.)
Gasket thickness	1.13 ± 0.05mm (0.0445 ± 0.0019in.)	1.23 ± 0.05mm (0.0484 ± 0.0019in.)	1.33 ± 0.05mm (0.0523 ± 0.0019in.)
Limit of each rank extant	0.43mm (0.0169in.)	0.53mm (0.0208in.)	-
Identification code	_____		

c. Install the gasket so that the identification mark faces toward the flywheel side.

3. Position the cylinder head assembly over the gasket.
4. Tighten the cylinder head bolts slightly.
5. Install the camshaft sprocket, aligning the timing mark.

Tightening torque

125 ~ 140N.m (1250 ~ 1400kgf.m, 92.19 ~ 103.26lb-ft)

6. Tighten the bolts to the specified torque

Tightening torque

50N.m (500kgf.m, 36.9lb-ft) + 120° + 120°

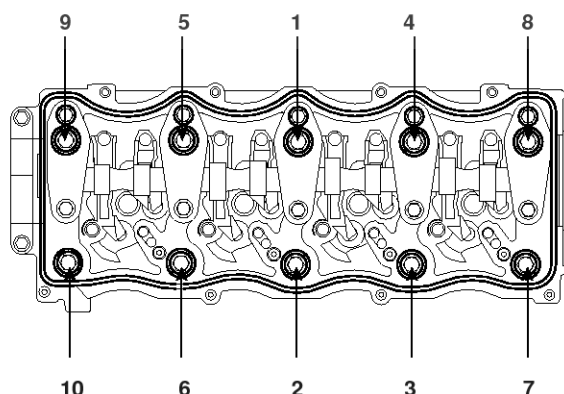

ACIE094A

NOTICE

- Tightening sequence of cylinder head bolt should be confirmed to the upper drawing.
- Cylinder head bolt must be replaced.

Cylinder Head Assembly

EM-39

7. Install the fuel pump assembly.
8. Install the intake/exhaust manifold assemblies.
9. Install the hose between the vacuum pump and the cylinder head.
10. If it is necessary to replace the oil seals on the cylinder head cover for injectors, use the SST(09351-27401).
11. Install the camshaft oil seal with use the SST(09212 - 27100)
12. Install the injector holder(A).

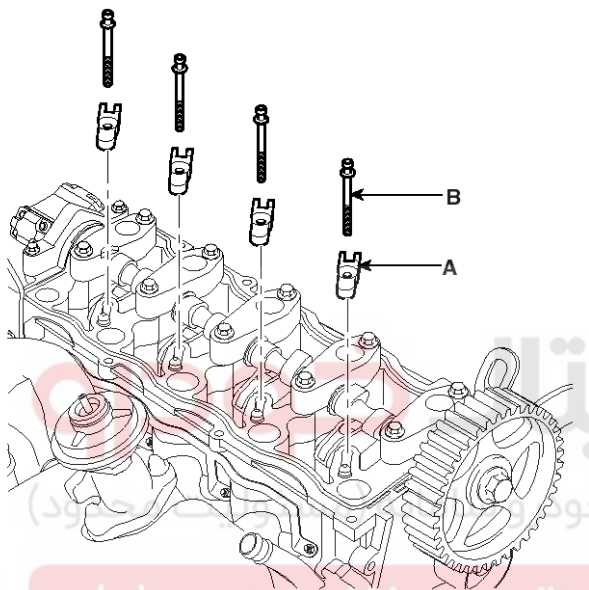

EDKD552A

13. Install the head cover gasket in the groove of the cylinder head cover.

NOTICE

- Cylinder head cover gasket must be replaced.
- Before installing the head cover gasket, thoroughly clean the seal and the groove.

14. Apply liquid gasket to the head cover gasket at the four corners of the recesses.

NOTICE

- Use liquid gasket LOCTITE 5699 or TH1212D.
- Check that the mating surface are clean and dry before applying liquid gasket.
- Do not install the parts if five minutes or more have elapsed since applying liquid gasket. Instead, reapply liquid gasket after removing old residue.
- After assembly, wait at least 30 minutes before filling the engine with oil.

15. Install the cylinder head cover bolts(A, B).

Tighten torque

(A) : 21 ~ 25N.m (2.2 ~ 2.6kgf.m, 15.9 ~ 18.8lb-ft)

(B) : 8 ~ 10N.m (0.8 ~ 1.0kgf.m, 5.9 ~ 7.38lb-ft)

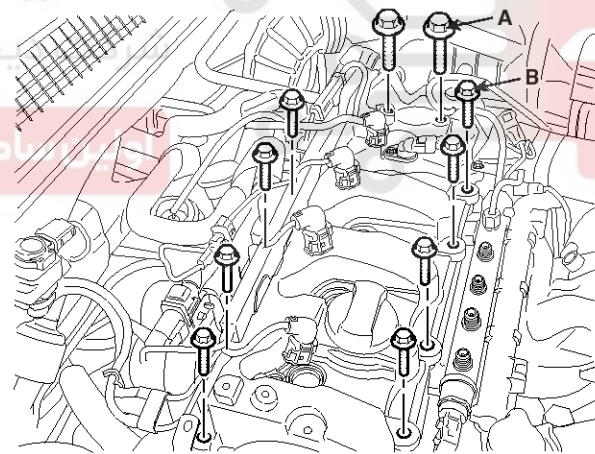

SNFEM6006D

NOTICE

After assembly, wait at least 30 minutes before filling the engine with oil.

EM-40

Engine Mechanical System

16. Insert the injectors(C), moving back the injector holders(A) with the bolts(B).

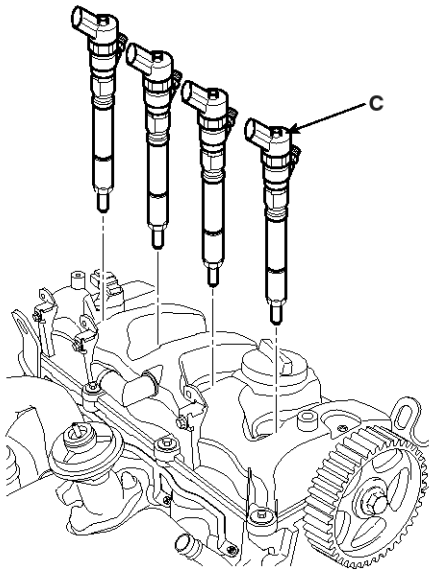

EDKD549C

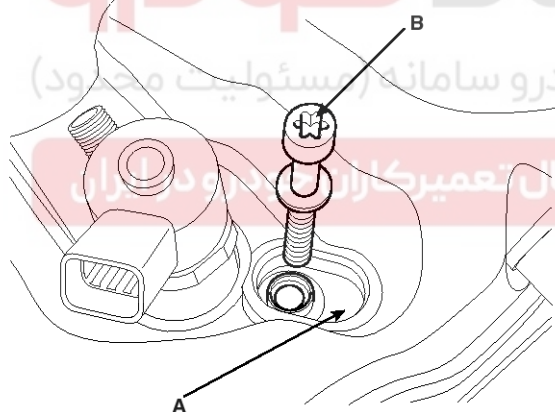

EDKD548A

17. Install the injector holder bolts using the torx wrench.

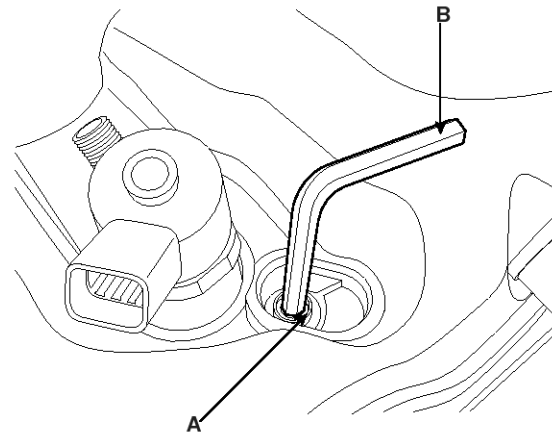

ACIE059A

18. Install the injector plug(A).

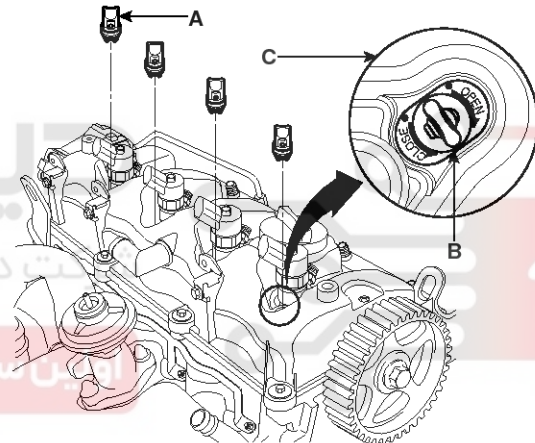

ACIE097A

- Make sure that the stopper of the plug faces 'OPEN' side. Otherwise pull and rotate the plug clockwise so the stopper should face 'OPEN' side.
- Apply the engine oil on the head cover mating surface or the gasket of the plug.
- Insert the plugs in the head cover.
- Rotate the plug inserted counterclockwise 90°.
- After installation, rotate the plug clockwise. If it is rotated, repeat the step a ~ d.

NOTICE

Plug gasket must be replaced.

19. Install the fuel tube. (See FL group - injector)

20. Install the timing belt.

Cylinder Block

EM-41

Cylinder Block

Components

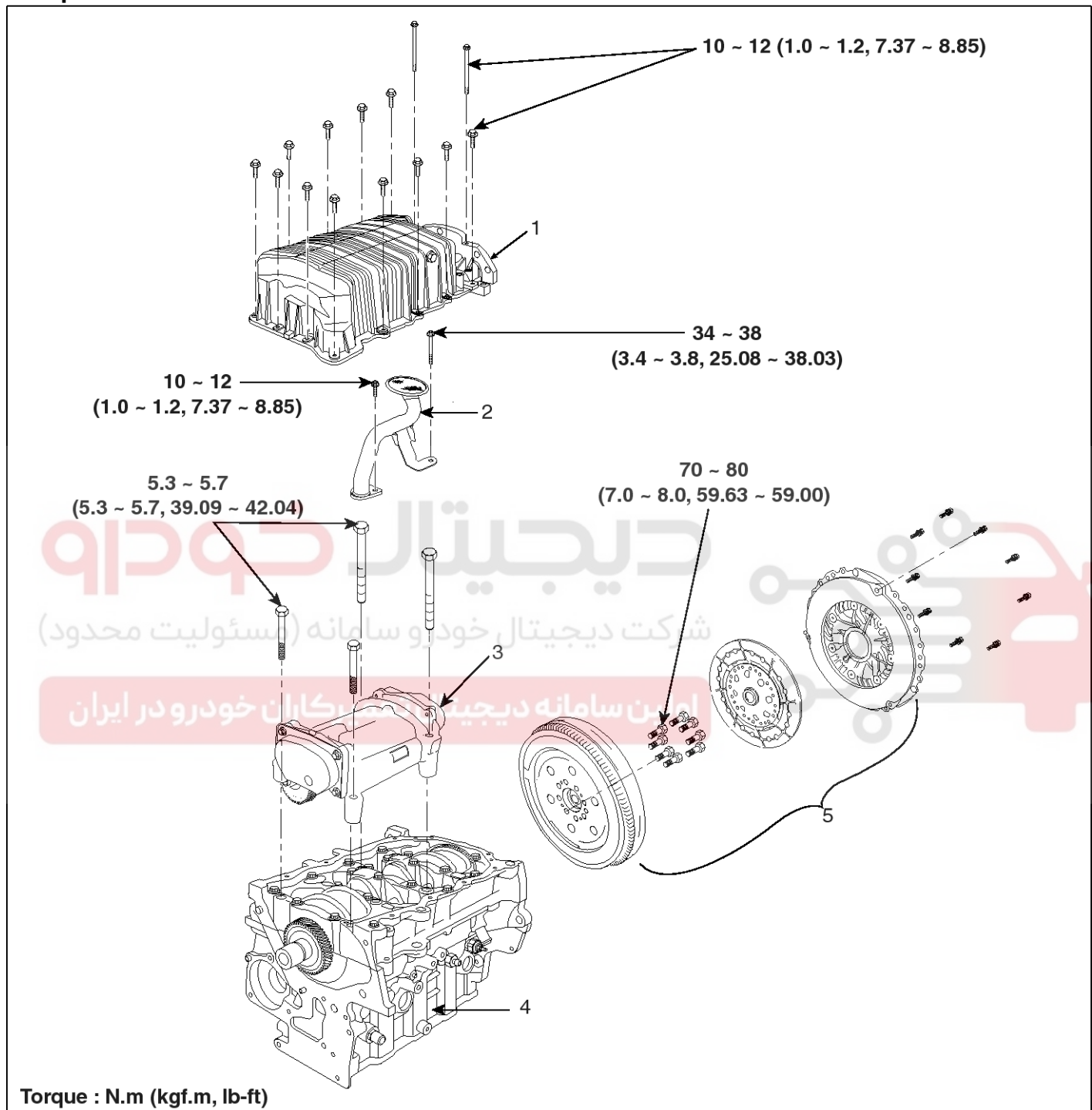

SMGM19013L

- 1. Oil pan
- 2. Oil screen
- 3. Balance shaft assembly
- 4. Cylinder block assembly
- 5. Flywheel & clutch cover assembly

EM-42

Engine Mechanical System

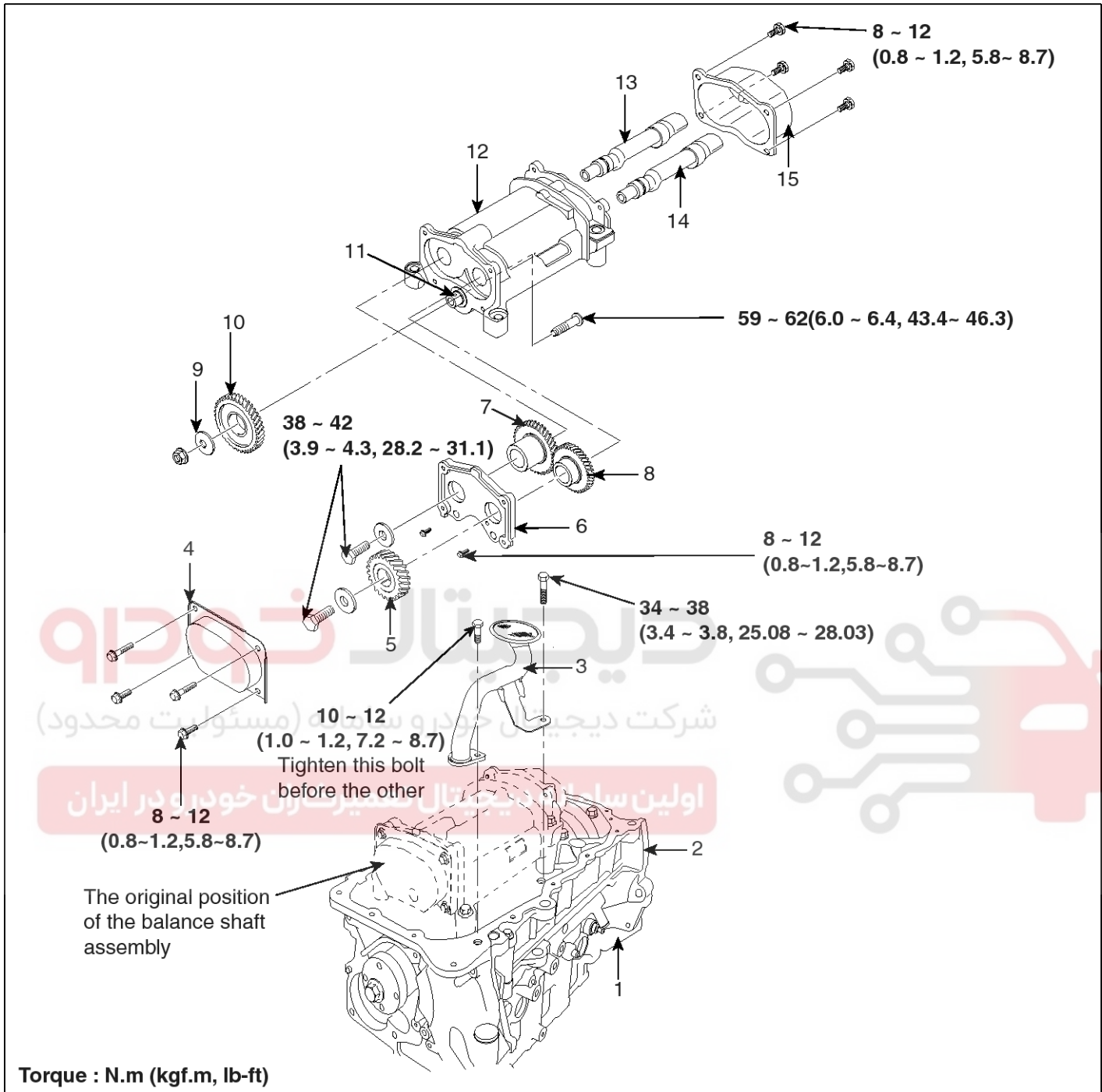

SMGM19014L

- | | | |
|--------------------------------------|------------------------------|--------------------------------------|
| 1. Engine block | 6. Balance shaft gear shim | 11. Intermediate gear shaft |
| 2. Bed plate | 7. Balance shaft driven gear | 12. Balance shaft carrier sub assy |
| 3. Oil screen | 8. Balance shaft driver gear | 13. Balance driven shaft |
| 4. Balance shaft carrier front cover | 9. Intermediate gear washer | 14. Balance driver shaft |
| 5. Balance shaft drive gear | 10. Intermediate gear | 15. Balance shaft carrier rear cover |

Cylinder Block

EM-43

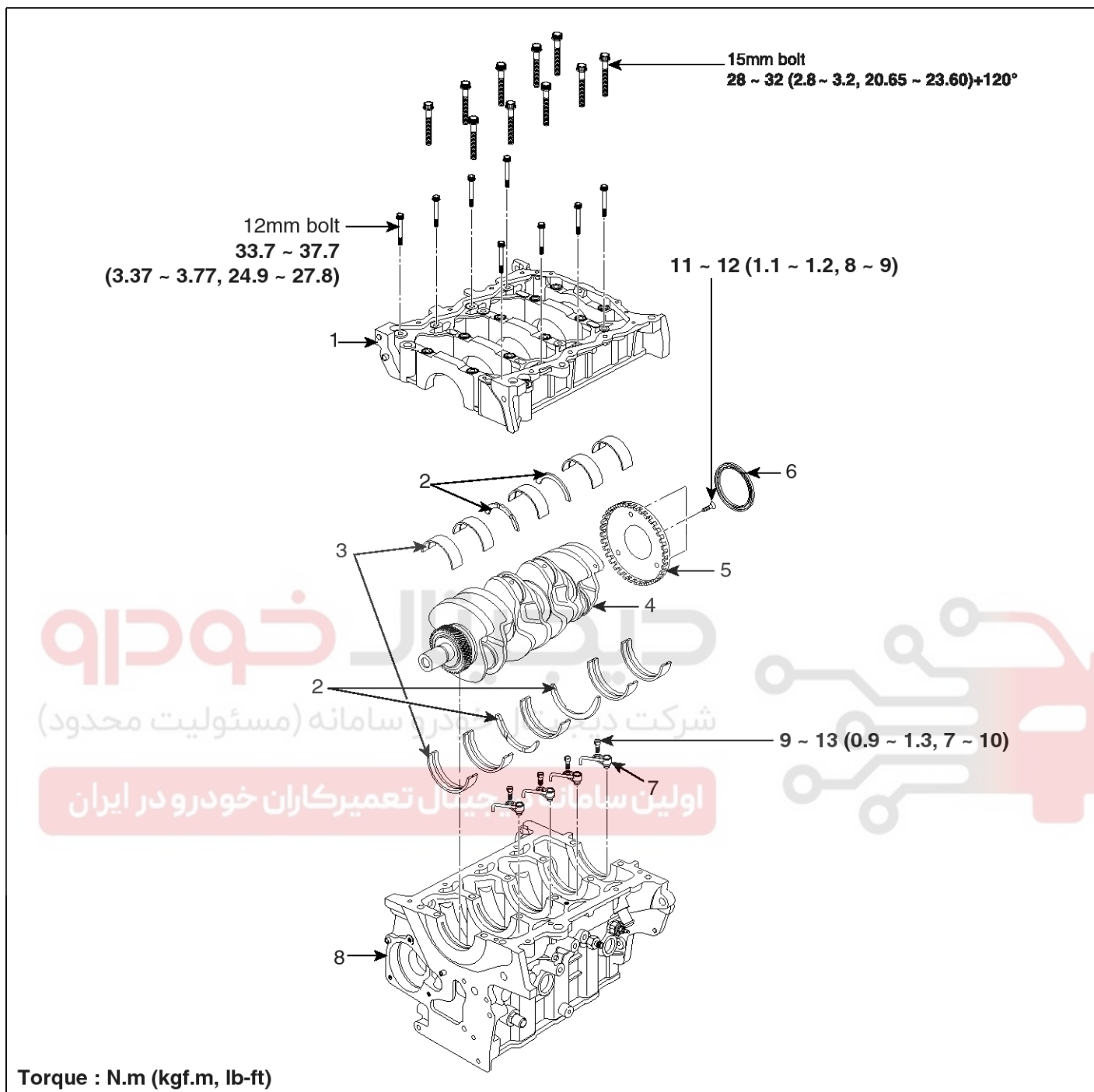

SMGM19015L

1. Bad plate
2. Center bearings
3. Main bearings
4. Crankshaft

5. Crankshaft position sensor wheel
6. Crankshaft rear oil seal
7. Piston cooling jet (Oil jet)
8. Engine block

EM-44

Engine Mechanical System

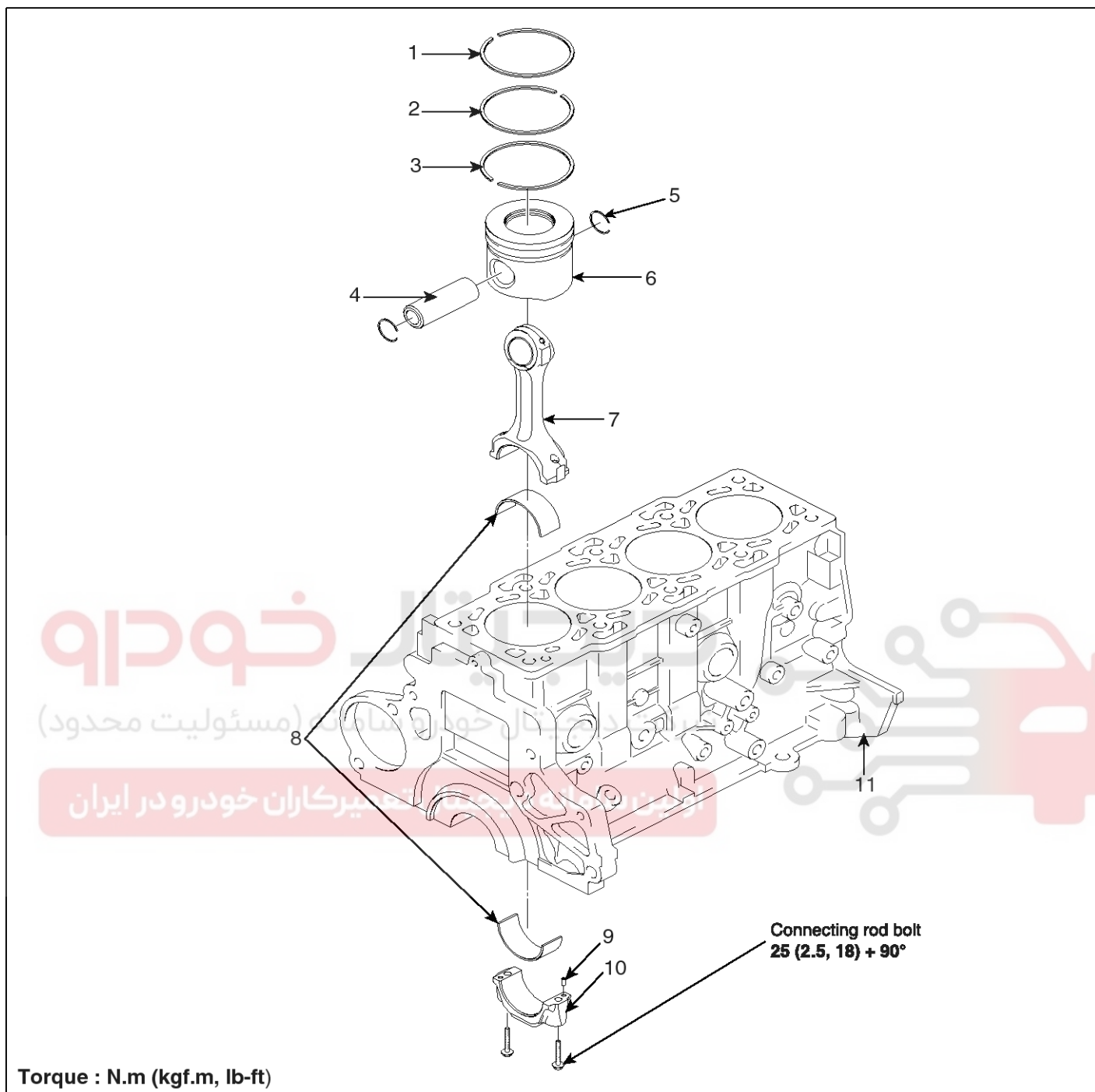

SMGM19016L

- 1. Piston ring No. 1
- 2. Piston ring No. 2
- 3. Oil ring
- 4. Piston pin
- 5. Snap ring
- 6. Piston

- 7. Connecting rod
- 8. Connecting rod bearings
- 9. Dowel pin
- 10. Connecting rod bearing cap
- 11. Engine block

Cylinder Block

EM-45

Removal

1. Remove the engine and transaxle assembly from the vehicle.
2. Remove the timing belt assembly.
3. Remove the intake and the exhaust manifold.
4. Remove the cylinder head assembly.
5. Remove the alternator. (See EE group - alternator)
6. Remove the engine oil level gauge(A).

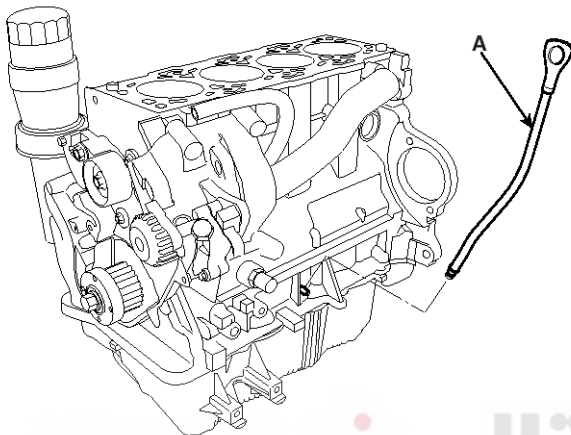

ACIE102A

7. Remove the Crankshaft Position Sensor(CKP)(A) and the oil pressure switch(B).

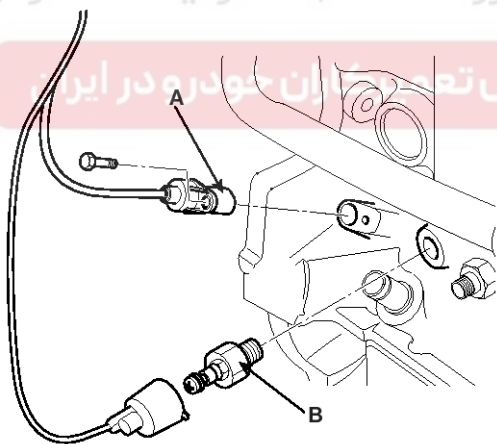

ACIE103A

8. Remove the heater and oil cooler return pipe assembly(A) after loosening the hose clamps(B) and the bolts(C, D, E).

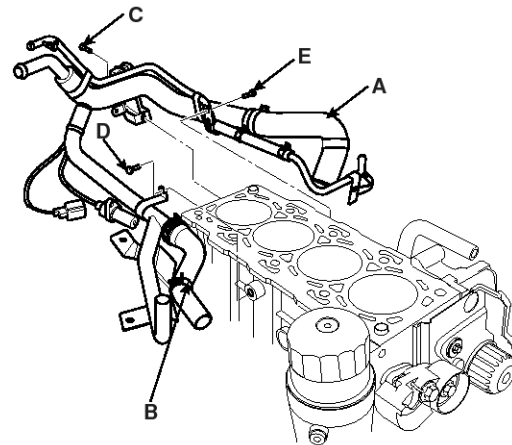

ACIE104A

9. Remove the tube(A) between the vacuum pump and the cylinder head.

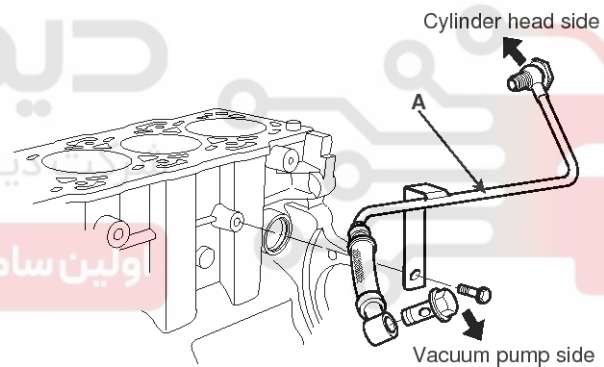

LCIF026A

EM-46

Engine Mechanical System

10.Remove the power steering pump mounting bracket assembly(A).(See ST group - Power steering)

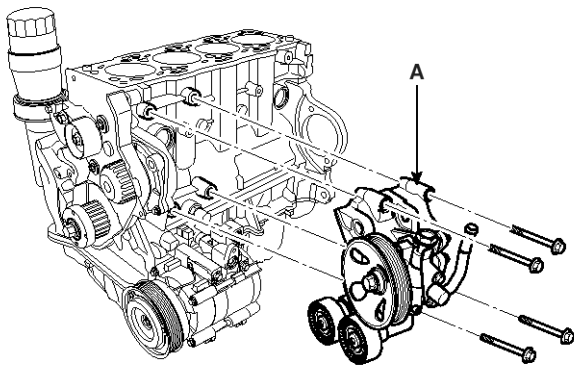

ACIE106A

11.Remove the water inlet pipe assembly(A) by loosening a bolt(B) and clamps.

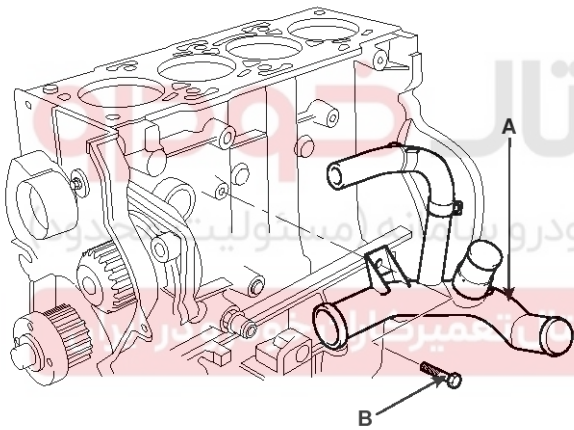

ACIE107A

12.Remove the air compressor(A). (See HA group - compressor)

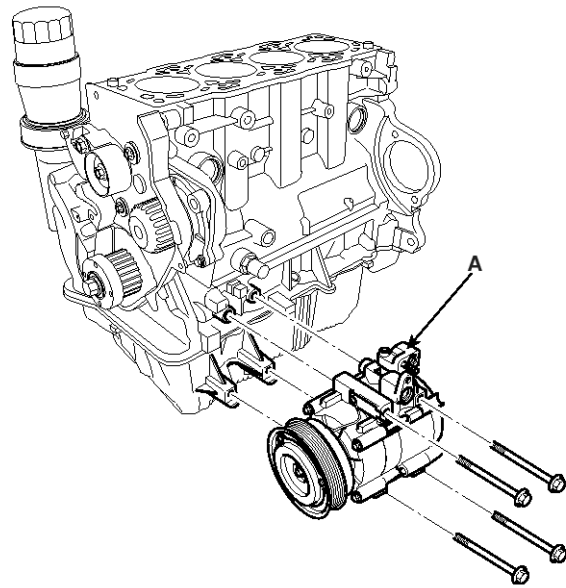

ACIE108A

13.Remove the auto-tensioner(A) by loosening the bolt(B).

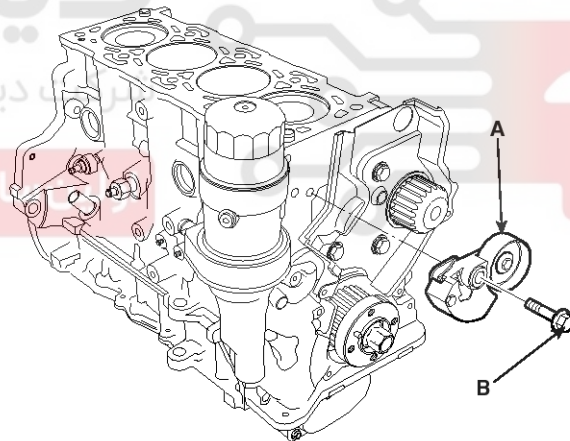

ACIE109A

Cylinder Block

EM-47

14. Remove the timing belt rear cover(A).

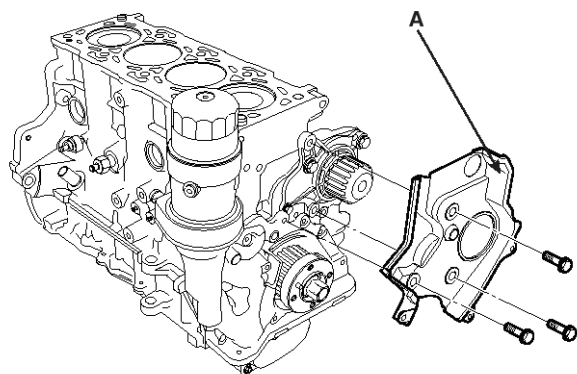

ACIE110A

15. Remove the water pump assembly(A) with the gasket(B).

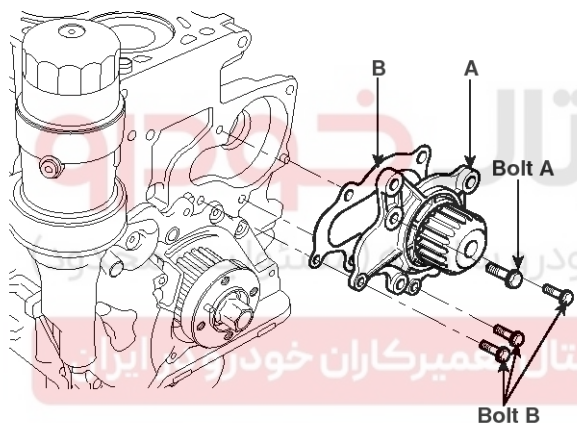

LCIF027A

16. Remove the oil pan(A) after removing the oil-pan acoustic shield.

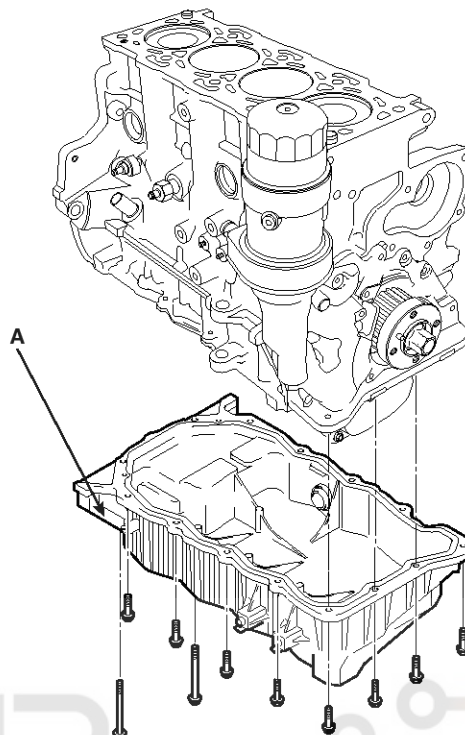

ACIE112A

NOTICE

An oil-pan acoustic shield can be also removed when removing a transmission from an engine.

17. Remove the oil screen(A) for removal of the oil pump case(B).

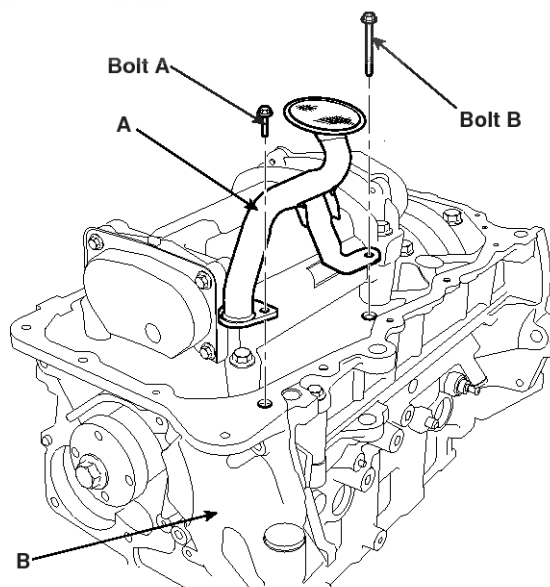

LCIF028A

EM-48

Engine Mechanical System

18. Remove the crankshaft bolt(A), then separate the crankshaft sprocket(B).

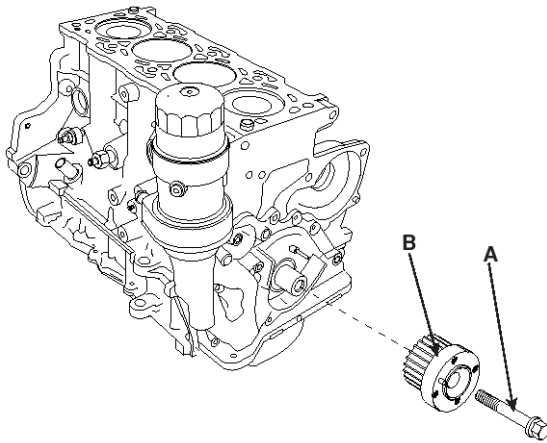

ACIE114A

19. Remove the oil-pump assembly(B) by loosening the bolts(A).

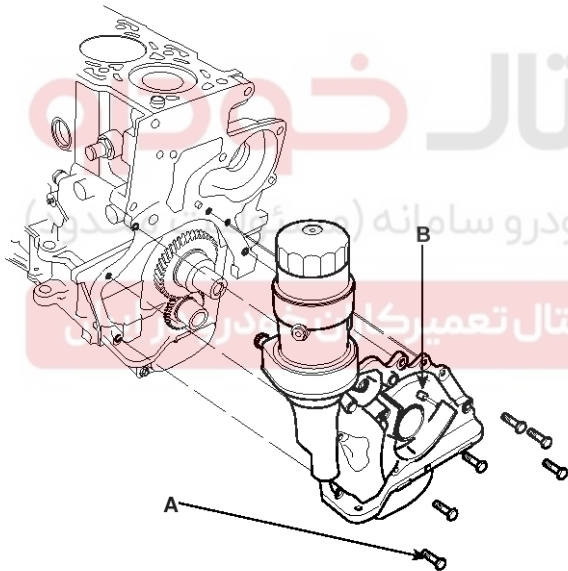

ACIE115A

20. Remove the crankshaft key(A).

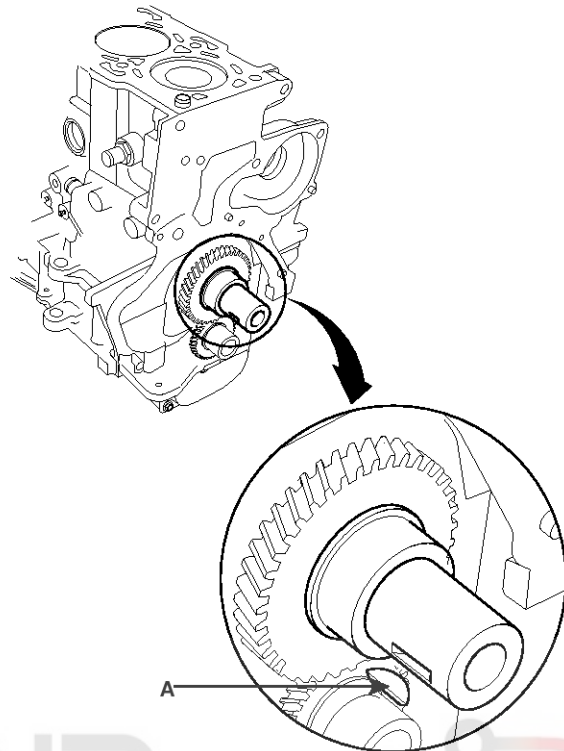

LCIF029A

Cylinder Block

EM-49

Replacement

Main Bearing Selection

Crankshaft Bore Code Location

1. Letters have been stamped on the end of the block as a code for the size of each of the 5 main journal bores. Write down the crank bore codes.

If you can't read the codes because of accumulated dirt and dust, do not scrub them with a wire brush or scraper. Clean them only with solvent or detergent.

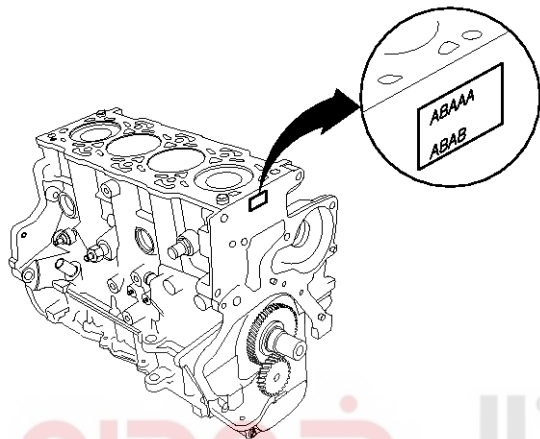

ACIE129A

Discrimination Of Cylinder Block

Discrimination		SIZE (mm) (Inside diameter of crank bore)
Class	Mark	
A	A	Ø64 (0 ~ +0.006)
B	B	Ø64 (+0.006 ~ +0.012)
C	C	Ø64 (+0.012 ~ +0.018)

Main Journal Code Locations

1. The main Journal Codes are stamped on the No.1 web.

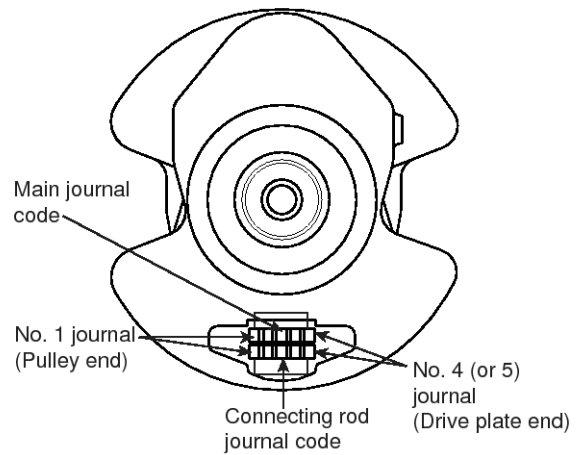

LCIF031A

Discrimination Of Crank Shaft

Discrimination		SIZE (mm) (Outside diameter of main journal)
Class	Mark	
I	A	Ø60 (+0.014 ~ +0.020)
II	B	Ø60 (+0.008 ~ +0.014)
III	C	Ø60 (+0.002 ~ +0.008)

EM-50

Engine Mechanical System

- Use the crank bore codes and crank journal codes to select the appropriate replacement bearings from the following table.

NOTICE

- Color code is on the edge of the bearing. Refer to the table in the step 6 of the main bearing clearance inspection.
- When using bearing halves of different colors, it dose not matter which color is used in the top or bottom.

Installing procedure of bearing

Shaft bore combination		Bearing mark	Oil clearance
Shaft mark	Bore mark		
I (A)	A (A)	A (Blue)	0.024 ~ 0.042 mm
	B (B)	B (Black)	
	C (C)	C (-)	
II (B)	A (A)	B (Black)	
	B (B)	C (-)	
	C (C)	D (Green)	
III (C)	A (A)	C (-)	
	B (B)	D (Green)	
	C (C)	E (Yellow)	

Rod Bearing Selection

- Inspect each connecting rod for cracks and heat damage.

Connecting Rod Big End Bore Code Locations

- Each rod has tolerance range from 0 to 0.018mm (0.0007in.), in 0.006mm (0.0002in.) increments, depending on the size of its big end bore. It's then stamped with a letter (A, B or C) indicating the range. You may find any combination of letters in any engine.

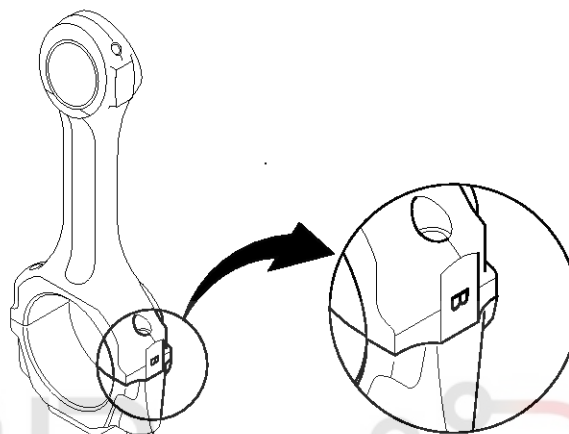

LCIF032A

NOTICE

Discrimination connecting rod

Discrimination		SIZE (mm)
Class	Mark	(Inside diameter of connecting rod big end bore)
A	A	Ø 53 (0 ~ +0.006)
B	B	Ø 53 (+0.006 ~ +0.012)
C	C	Ø 53 (+0.012 ~ +0.018)

Cylinder Block

EM-51

Connecting Rod Journal Code Locations

1. The connecting Rod Journal Codes are stamped on the No. 1 web.

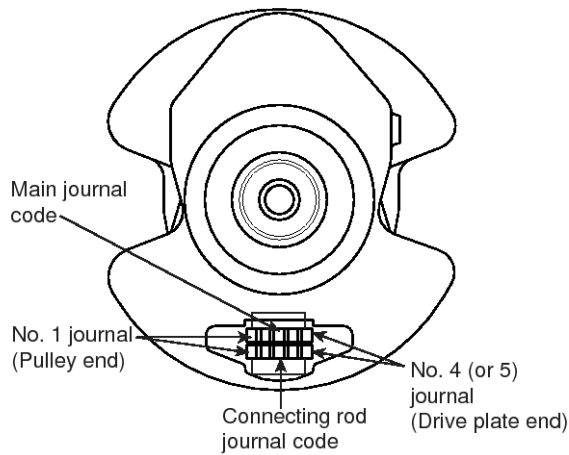

LCIF031A

NOTICE

Discrimination of crank shaft pin

Discrimination		SIZE (mm) (Outside diameter of pin)
Class	Mark	
I	A	Ø50 (+0.020 ~ +0.026)
II	B	Ø50 (+0.014 ~ +0.020)
III	C	Ø50 (+0.008 ~ +0.014)

2. Use the big end bore codes and rod journal codes to select appropriate replacement bearings from the following table.

NOTICE

Color code is on the edge of the bearing.

Refer to the table in the step 5 of rod bearing clearance inspection.

Shaft bore combination		Bearing mark	Oil clearance
Shaft mark	Bore mark		
I	A (A)	A (Blue)	0.024 ~ 0.042 mm
	B (B)	B (Black)	
	C (C)	C (White)	
II	A (A)	B (Black)	
	B (B)	C (White)	
	C (C)	D (Green)	
III	A (A)	C (White)	
	B (B)	D (Green)	
	C (C)	E (Yellow)	

EM-52

Engine Mechanical System

Piston, Pin and Connecting Rod

1. Apply engine oil to the piston pin snap rings and turn them in the ring grooves.

NOTICE

Take care not to damage the ring grooves.

2. Remove both snap rings(A) carefully so they do not go flying or get lost. Wear eye protection.

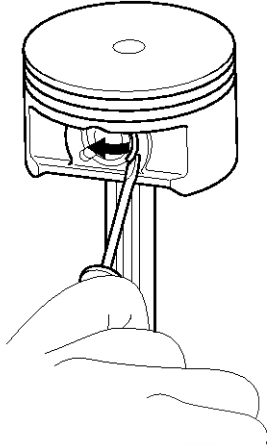

LCIF033A

3. Remove the piston pin and the connecting rod assembly.
4. Measure the diameter of the piston pin.

Piston Pin Diameter

Standard (New)

27.995 ~ 28.000mm (1.1022 ~ 1.1024in.)

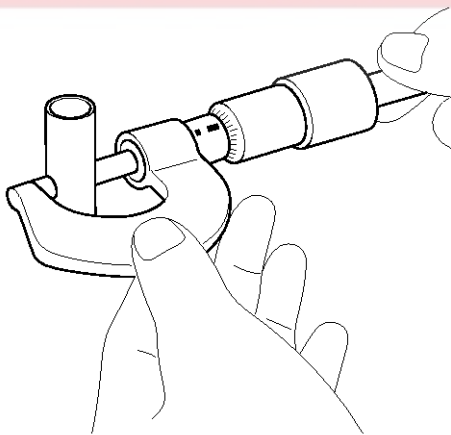

ACIE134A

NOTICE

Inspect the piston, piston pin and connecting rod when they are at room temperature.

5. Zero the dial indicator to the piston pin diameter.
6. Check the difference between the piston pin diameter and piston pin hole diameter in the piston.

Piston Pin-to-Piston Clearance

Standard (New)

0.015 ~ 0.030mm (0.00059 ~ 0.00118in.)

7. Measure the piston pin-to-connecting rod clearance.

Piston Pin-to-Connecting Rod Clearance

Standard (New)

0.022 ~ 0.039mm (0.00087 ~ 0.00154in.)

8. Set a snap ring in one side of piston pin hole.
9. Before inserting the piston pin, apply a sufficient amount of the lubricant oil to the outer surface of the piston, the inner surface of the piston pin hole and the small end bore of the connecting rod.
10. Insert the piston pin(A). Assemble the piston and connecting rod with the embossed front marks on the same side.

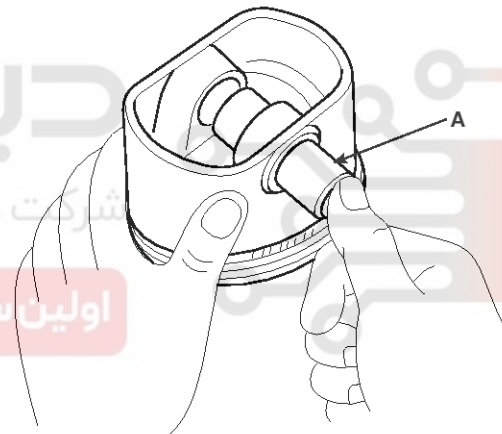

ACIE133A

NOTICE

The front mark of the piston is embossed on the piston whereas some letters are located on a side surface of the connecting rod as the front mark.

CAUTION

- Be sure to keep the small end bore, piston pin hole and piston pin undamaged and unscratched when inserting the piston pin.
- Set the snap rings to be sure for contacting with the groove of the piston pin hole.

Cylinder Block

EM-53

Piston Ring

- Using a piston, push a new ring into the cylinder bore.

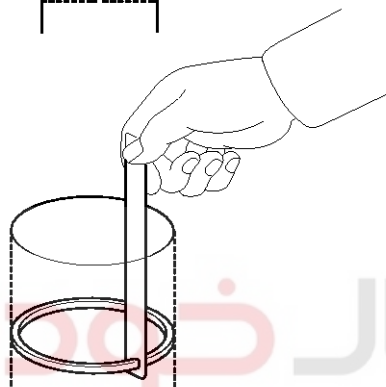
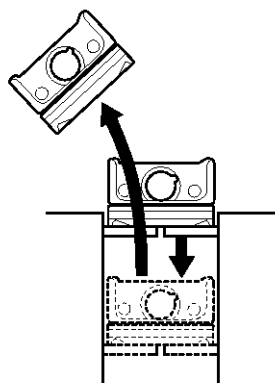

ACIE137A

- Measure the piston ring end-gap(B) with a feeler gauge :
 - If the gap is too small, check to see if you have the proper rings for your engine.
 - If the gap is too large, recheck the cylinder bore diameter against the wear limits.

If the bore is over the service limit, the cylinder block must be rebored.

Piston Ring End-Gap

Top ring

Standard (New) : 0.20 ~ 0.30mm (0.008 ~ 0.012in.)

Second Ring

Standard (New) : 0.30 ~ 0.45mm (0.012 ~ 0.018in.)

Oil Ring

Standard (New) : 0.20 ~ 0.40mm (0.008 ~ 0.016in.)

- Using a ring expander, remove the old piston rings.
- Clearance all ring grooves thoroughly with a squared-off broken ring or ring groove cleaner with a blade to fit the piston grooves.

Top ring groove

1.915 ~ 1.945mm (0.07539 ~ 0.07657in.)

2nd ring groove

2.060 ~ 2.080mm (0.08110 ~ 0.08189in.)

Oil ring groove

3.020 ~ 3.040mm (0.11889 ~ 0.00968in.)

File down a blade if necessary.

Do not use a wire brush to clean the ring grooves, or cut the ring grooves deeper with cleaning tools.

NOTICE

If the piston is to be separated from the connecting rod, do not install new rings yet.

- Install the piston rings.

Piston Ring Dimensions

Top Ring (Standard)

Width : 2.95 ~ 3.25mm (0.116 ~ 0.128in.)

Thickness : 2mm (0.079in.)

Second Ring (Standard)

Width : 3.60 ~ 3.90mm (0.142 ~ 0.154in.)

Thickness : 1.970 ~ 1.995mm (0.078 ~ 0.079in.)

EM-54

Engine Mechanical System

6. After installing a new set of rings, measure the ring-to-groove clearances :

Top Ring Clearance

Standard (New)

0.064 ~ 0.114mm (0.00252 ~ 0.00449in.)

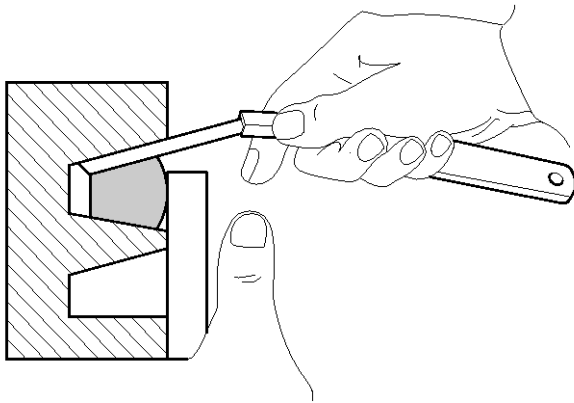

ACIE135A

Second Ring Clearance

Standard (New)

0.065 ~ 0.110mm (0.00256 ~ 0.00433in.)

Oil Ring Clearance

Standard (New)

0.03 ~ 0.07mm (0.00118 ~ 0.00275in.)

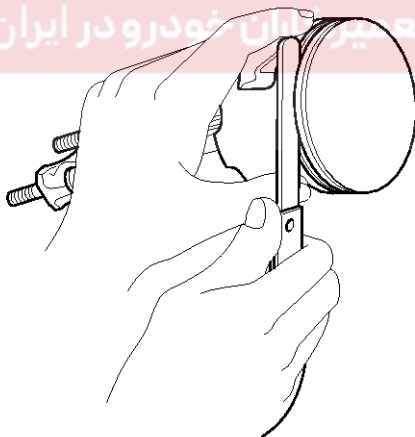

ACIE136A

Disassembly

1. Remove the balance shaft assembly(A) by loosening the flange bolts(B, C).

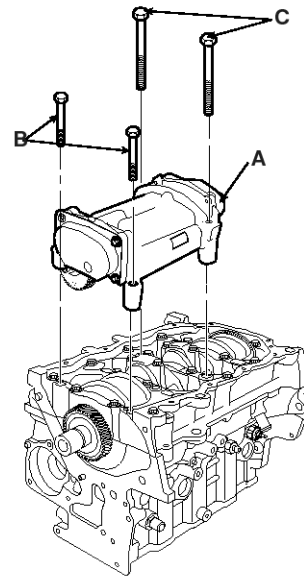

ACIE116A

2. Remove the bed plate assembly.

- Remove the bolts(A).

To prevent warpage, unscrew the bolts in sequence 1/3 turn at a time : repeat the sequence until all bolts are loosened.

- Remove the bolts(B).

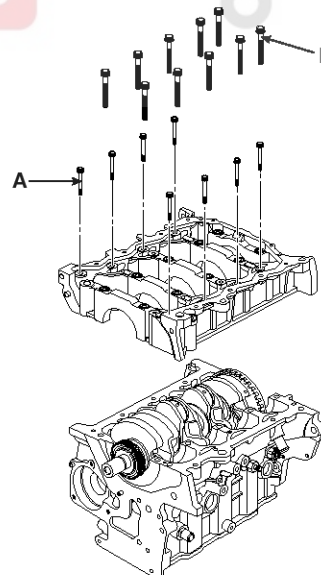

ACIE117A

Cylinder Block

EM-55

3. Remove the connecting rod bearing caps(A) and bearings(B).

- After removing No. 1 and 4 connecting rod bearing caps and turn the crankshaft No. 2 and 3 crankpins are at the top.
- Remove the rest bearing caps and bearings.
- Keep all caps/bearings in order.

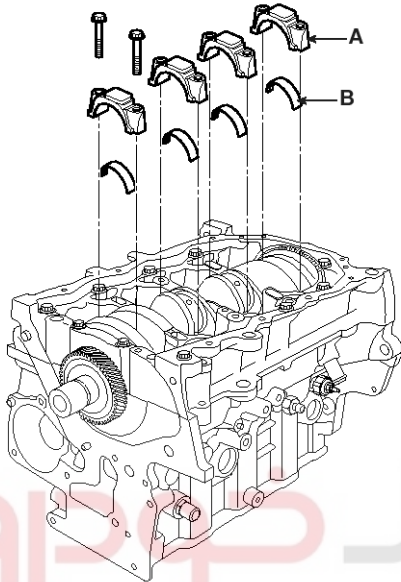

ACIE118A

4. If you can feel a ridge of metal or hard carbon around the top of each cylinder, remove it with a ridge reamer. Follow the reamer manufacturer's instructions. If the ridge is not removed, it may damage the pistons as they are pushed out.

5. Drive out the piston assembly from the engine block.
- Reinstall the connecting rod bearings and caps after removing each piston/connecting rod assembly.
 - To avoid mixup on reassembly, mark each piston/connecting rod assembly with its cylinder number.

6. Lift the crankshaft(A) out of the engine block(B), being careful not to damage the journals.

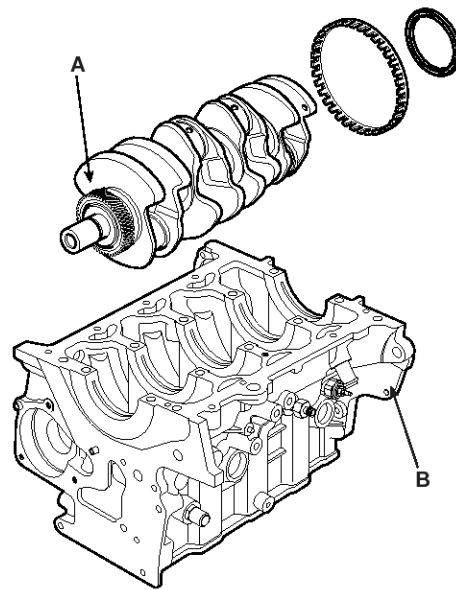

ACIE119A

7. Remove the piston oil jet(A) by loosening the torx bolt(B) with a torx wrench.

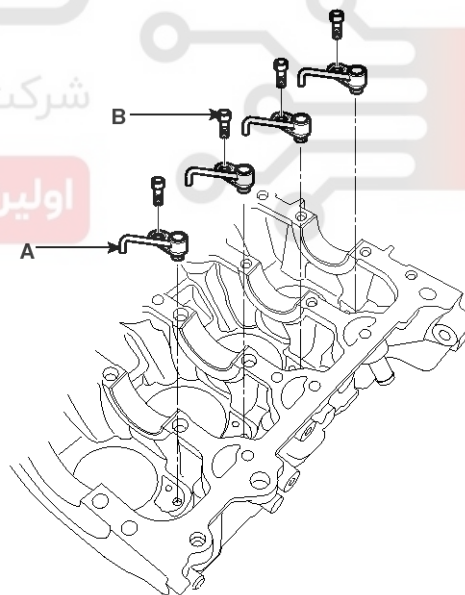

ACIE120A

EM-56

Engine Mechanical System

Balancer

1. Remove the balance shaft carrier front/rear cover(A, B).

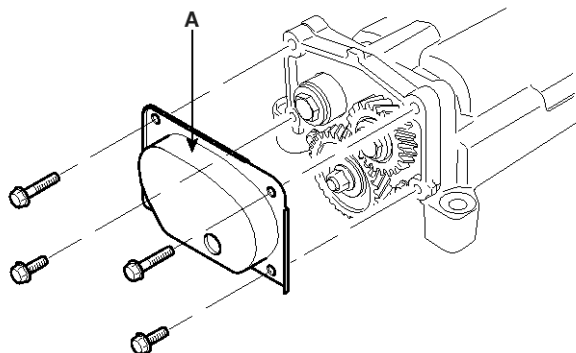

ACIE121A

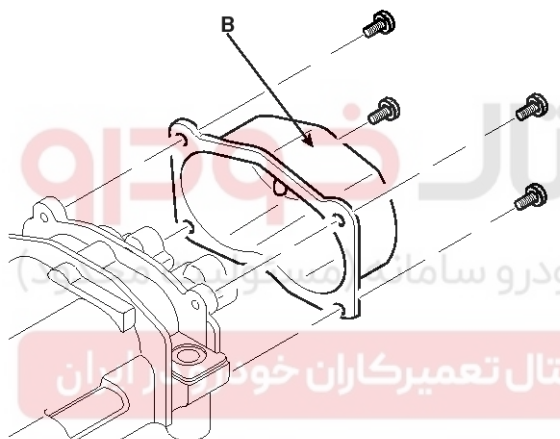

ACIE122A

2. Remove the intermediate gear assembly(B).

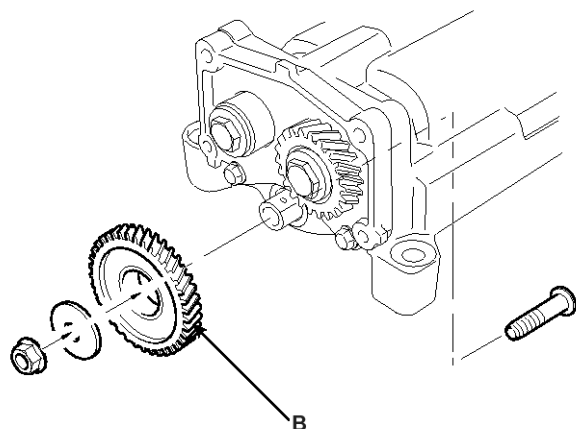

ACIE123A

3. Remove the balance shaft drive gear(A).

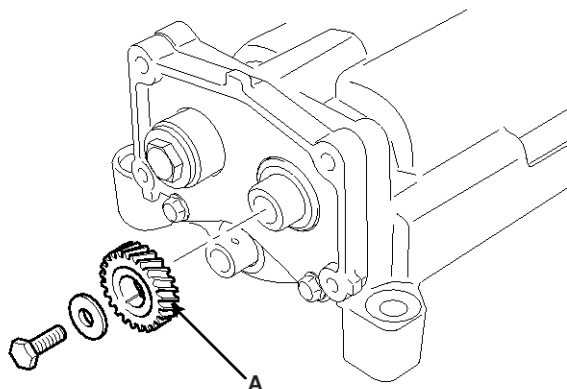

ACIE124A

4. Remove the balance shaft gear shim(A).

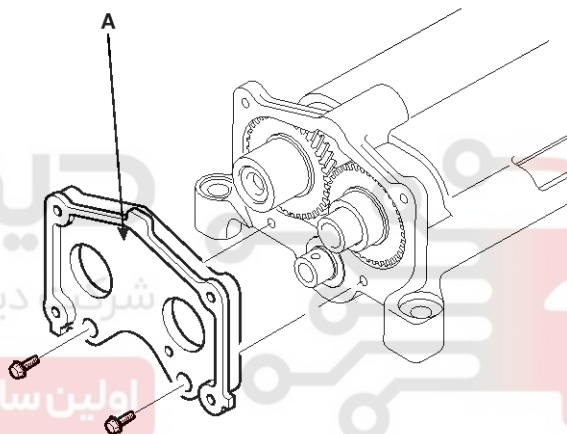

ACIE125A

5. Remove the balance shaft driver gear(A).

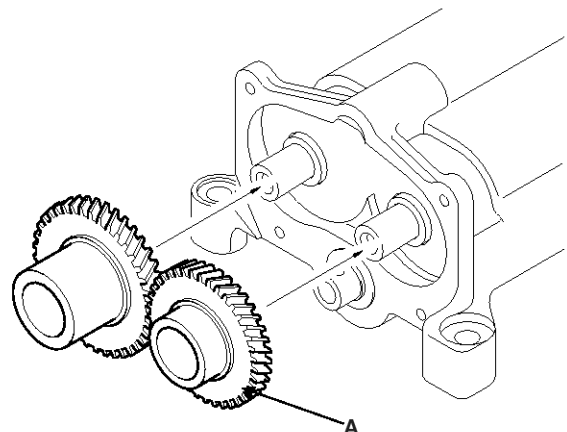

ACIE126A

Cylinder Block

EM-57

6. After loosening the balance shaft gear bolt, remove the balance shaft driven gear(B).

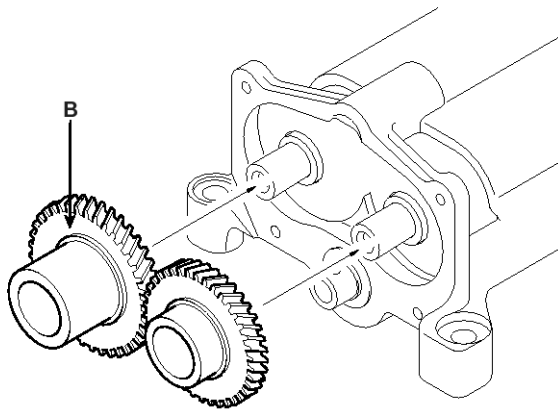

LCIF030A

7. Remove the balance driver/driven shafts(A, B).

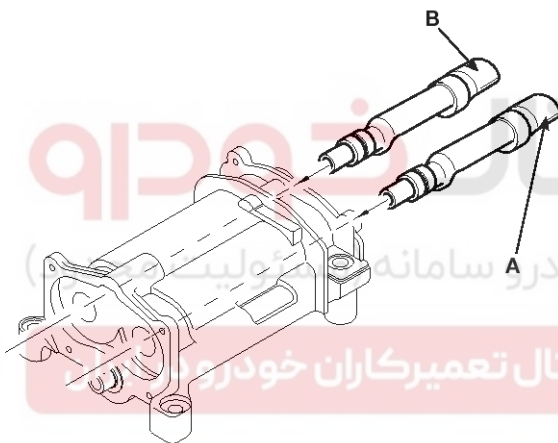

ACIE127A

Inspection

Flywheel

1. Inspect ring gear teeth for wear or damage.
2. Flywheel bolts should be free from detrimental flaws.

Connecting Rod and Crankshaft End Play

1. Measure the connecting rod end play with a feeler gauge(A) between the connecting rod(B) and crankshaft(C).

Connecting Rod End play

Standard (New) : 0.10 ~ 0.35mm (0.004 ~ 0.014in.)

Service Limit : 0.40mm (0.016in.)

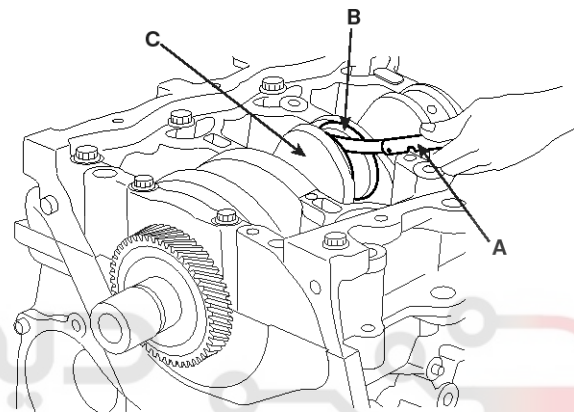

ACIE131A

2. If the connecting rod end play is out-of-tolerance, install a new connecting rod, and recheck. If it is still out-of-tolerance, replace the crankshaft.
3. If the end play is excessive. Replace parts as necessary.

EM-58

Engine Mechanical System

Main Bearing Clearance

1. To check main bearing-to-journal oil clearance, remove the bed plate, the crankshaft and the bearing halves.
2. Clean each main journal and bearing half with a clean shop towel.
3. Cut plastigauge to the same length as the width of the bearing.
4. Place one strip of plastigauge across each main journal on the cylinder block and the bed plate, avoiding the oil holes.
5. Reinstall the bearings, crankshaft and bed plate then torque the bolts to the specified value.

NOTICE

Do not rotate the crankshaft during inspection.

6. Remove the bed plate and bearings again and measure the widest part of the plastigauges with a calibrated scale on which an arrow of marks has been printed.

Main bearing-to-journal Oil Clearance

Standard (valve)

0.024 ~ 0.042mm (0.0009 ~ 0.0017in.)

NOTICE

Discrimination of crankshaft main bearing

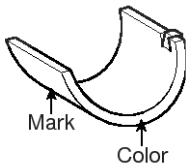
Discrimination		SIZE (mm) (Thickness of bearing)	Place of identification mark
Class	Mark		
E	Yellow	1.987~1.990	
D	Green	1.984~1.987	
C	-	1.981~1.984	
B	Black	1.978~1.981	
A	Blue	1.975~1.978	

7. If the plastigauge measure too wide or too narrow, remove the crankshaft, and remove the upper half of the bearing. Install a new, complete bearing with the same color code(s), and recheck the clearance. Do not file, shim, or scrape the bearings to adjust clearance.
8. If the plastigauge shows the clearance is still incorrect, try the next larger or smaller bearing (the color listed above or below that one), and check again. If the proper clearance cannot be obtained by using the appropriate larger or smaller bearings, replace the crankshaft and start over.

Rod Bearing Clearance

1. Remove the connecting rod cap and bearing half.
2. Clean the crankshaft rod journal bearing half with a clean shop towel.
3. Place pastigauge across the rod journal.
4. Reinstall the bearing half and cap, and torque the bolt.

NOTICE

Do not rotate the crankshaft during inspection.

5. Remove the rod cap and bearing half and measure the widest part of the plastigauge.

Connecting Rod Bearing-to-Journal Oil

Clearance : 0.024 ~ 0.042mm (0.0009 ~ 0.0017in.)

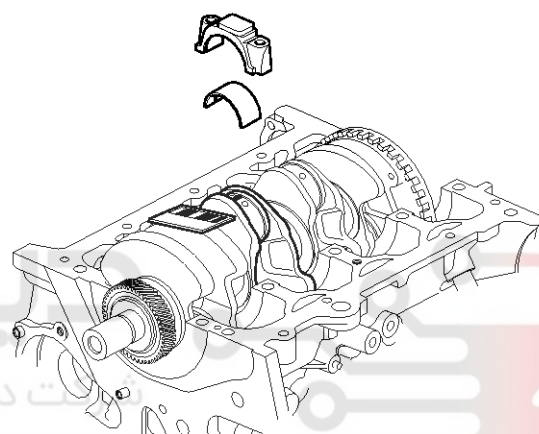

ACIE132A

Cylinder Block

EM-59

- If the plastigauge measure too wide or too narrow, remove the upper half of the bearing, install a new, complete bearing with the same color code(s), and recheck the clearance. Do not file, shim, or scrape the bearings or the caps to adjust clearance.

NOTICE

Discrimination of connecting rod bearing

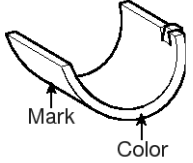
Discrimination		Size (Thickness of bearing)	Place of Identificati- on
Class	Mark		
E	Yellow	1.484 ~ 1.487	
D	Green	1.481 ~ 1.484	
C	White	1.478 ~ 1.481	
B	Black	1.475 ~ 1.478	
A	Blue	1.472 ~ 1.475	

- If the plastigauge shows the clearance is still incorrect, try the next larger or smaller bearings (the color listed above or below that one), and check clearance again. If the proper clearance cannot be obtained by using the appropriate larger or smaller bearing, replace the crankshaft and start over.

Balancer Shafts

- Measure runout on the journals of each balance shaft(A) to make sure the balancer shafts are not bent.

Balancer Shaft Total Indicated Runout

Standard (New) : 0.025mm (0.00098in.)

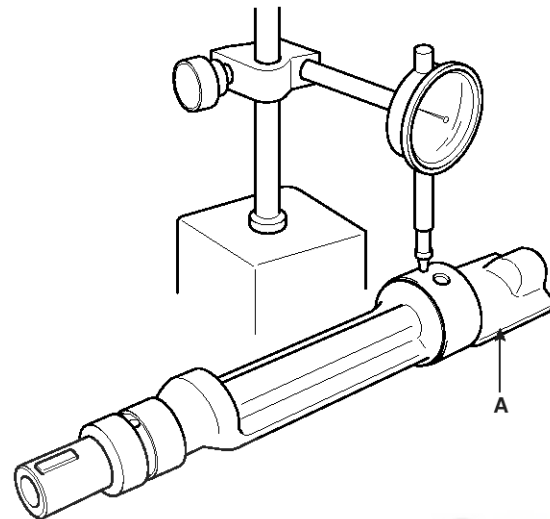

LCIF034A

- Measure the diameters of the journals on the balance shafts(A).

Journal Diameter

Standard (New)

No. 1 journal :

19.980 ~ 19.993mm (0.7866 ~ 0.7871in.)

No. 2 journal :

27.99 ~ 28.01mm (1.1020 ~ 1.1028in.)

No. 3 journal :

41.99 ~ 42.01mm (1.6531 ~ 1.6539in.)

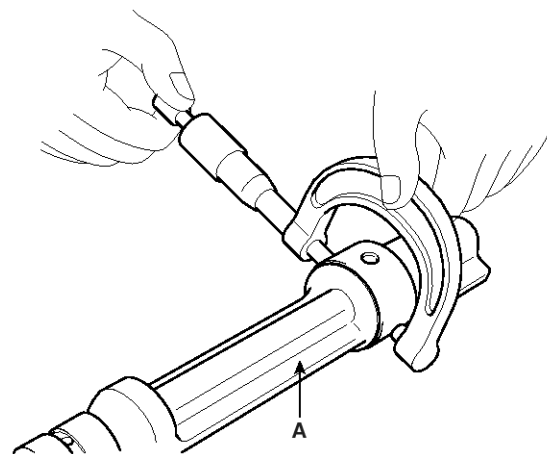

LCIF035A

EM-60**Engine Mechanical System**

3. Measure the inner diameters of the bearings for the balance shafts.

Bearing Inner Diameter

Standard (New)

No. 1 journal :

20.00 ~ 20.02mm (0.7874 ~ 0.7882in.)

No. 2 journal :

28.06 ~ 28.08mm (1.1047 ~ 1.1055in.)

No. 3 journal :

42.06 ~ 42.08 (1.6559 ~ 1.6567in.)

4. Calculate the shaft-to-bearings oil clearances.

$$\text{BEARING I.D} - \text{JOURNAL O.D} = \text{OIL CLEARANCE}$$

Shaft-to-Bearings Oil clearance

Standard (New)

No. 1 journal :

0.007 ~ 0.041mm (0.00028 ~ 0.00161in.)

No. 2 journal :

0.050 ~ 0.090mm (0.00197 ~ 0.00354in.)

No. 3 journal :

0.050 ~ 0.090mm (0.00197 ~ 0.00354in.)

Crankshaft**Straightness****NOTICE**

- Clean the crankshaft oil passages with pipe cleaners or a suitable brush.

- Check the keyway and threads.

1. Support the crankshaft with V-blocks.
2. Measure runout on all main journals to make sure the crank is not bent. Rotate the crankshaft two complete revolutions. The difference between measurements on each journal must not be more than the standard value.

Crankshaft Total Indicator Runout

Standard (New) : 0.06mm (0.002in.) max.

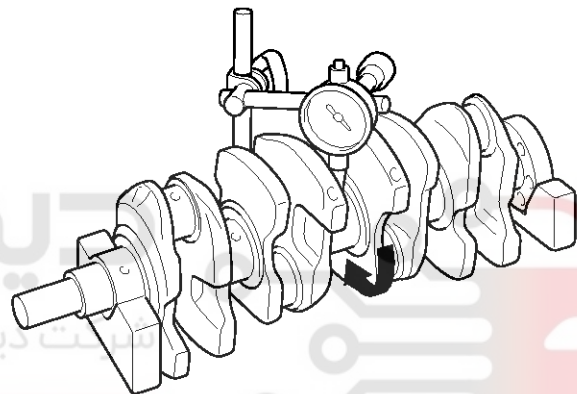

LCIF036A

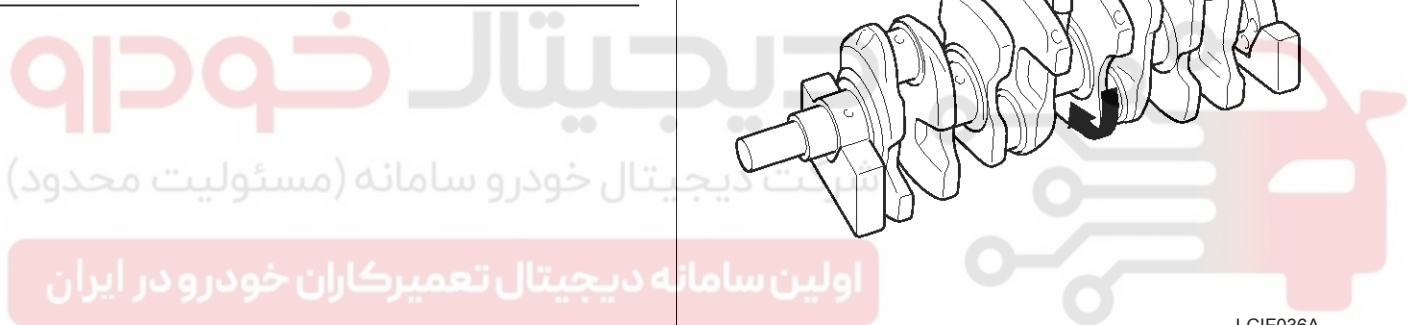

Cylinder Block

EM-61

Out-of-Round and Taper

1. Measure out-of-round at the middle of each rod and main journal in two places. The difference between measurements on each journal must not be more than the service limit.

Journal Out-of-Round

Standard (New) : 0.0035mm (0.0001in.) max.

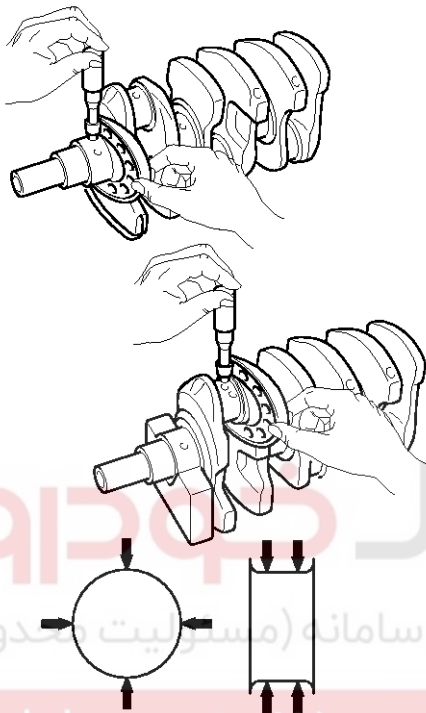

LCIF037A

2. Measure taper at the edge of each rod and main journal. The difference between measurements on each journal must not be more than the service limit.

Journal Taper

Standard (New) : 0.006mm (0.0002in.) max.

Block and Piston

1. Check the piston for distortion or cracks.
2. Measure the piston diameter at a point 10mm (0.4in) from the bottom of the skirt. There are three standard-size pistons (A, B and C). The letter is stamped on the top of the piston. Letters are also stamped on the block as cylinder bore sizes.

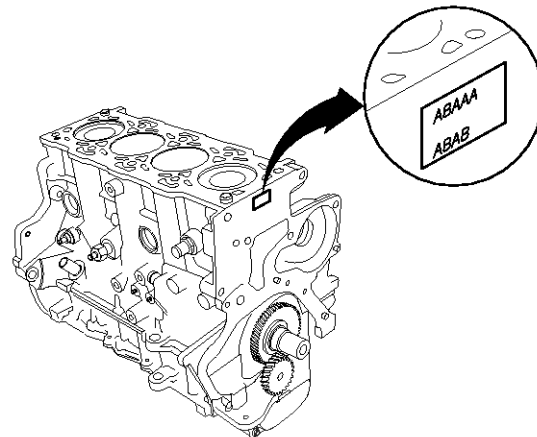

ACIE129A

Piston Diameter and Cylinder Bore

Standard value :

Grade	A	B	C
Piston Outer Diameter (mm)	82.92 ~ 82.93	82.93 ~ 82.94	82.94 ~ 82.95
Cylinder Bore (mm)	83.00 ~ 83.01	83.01 ~ 83.02	83.02 ~ 83.03
Clearance (mm)	0.070 ~ 0.090		

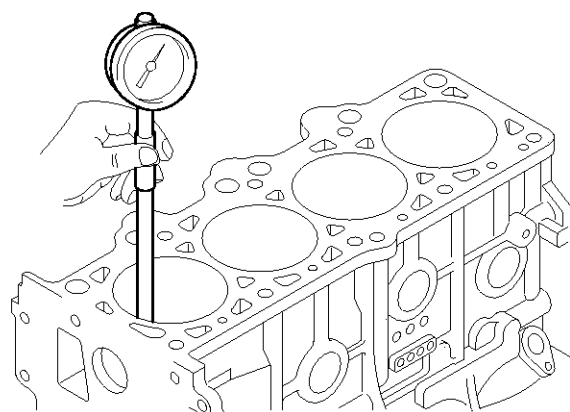

ACIE139A

EM-62

Engine Mechanical System

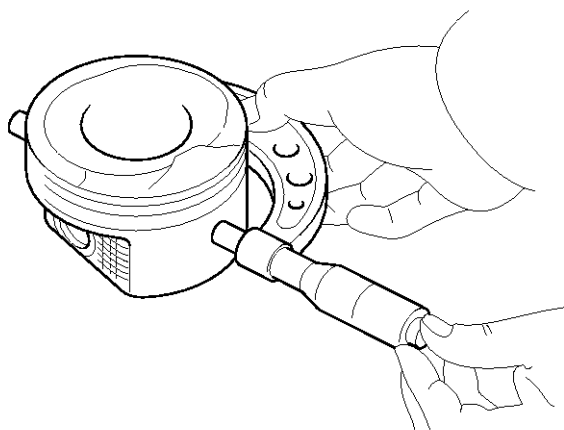

ACIE140A

3. Measure wear and taper in direction X and Y at three levels in each cylinder as shown. If measurements in any cylinder are beyond the cylinder bore standard value (Refer to the previous page), replace the block. If the block is to be rebored, refer to step 6 after reboring.

Oversize

0.25 : 83.250 ~ 83.280mm (3.2776 ~ 3.2787in.)

0.50 : 83.500 ~ 83.530mm (3.2874 ~ 3.2886in.)

Bore Taper

Limit : (Difference between first and third measurement)

0.01mm (0.0004in.) MAX.

Level 1 : No. 1 piston ring position at TDC(Top Dead Center).

Level 2 : Center of cylinder.

Level 3: Bottom of cylinder.

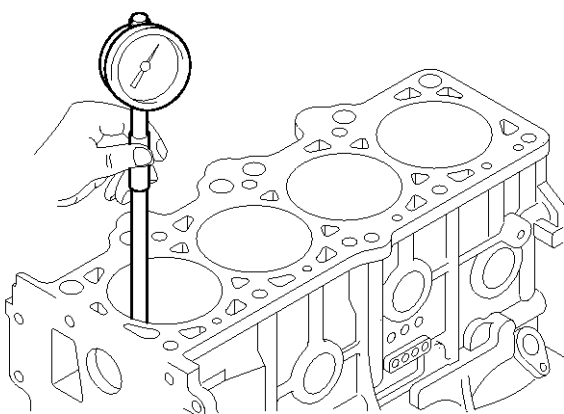

ACIE139A

4. Scored or scratched cylinder bores must be honed.
5. Check the top of the block for warpage. Measure along the edges and across the center.

Engine Block Warpage

Standard (New)

0.042mm (0.00165in.) for width

0.096mm (0.00378in.) for length

0.012mm (0.00047in.)/50×50mm

Service Limit : 0.10mm (0.004in.)

6. Calculate the difference between the cylinder bore diameter and the piston diameter. If the clearance is near or exceeds the standard value, inspect the piston and cylinder block for excessive wear.

Piston-to-Cylinder Clearance

Standard (New) :

0.070 ~ 0.090mm (0.0028 ~ 0.0035in.)

Oversize Piston Diameter :

0.25 : 83.170 ~ 83.200mm (3.2744 ~ 3.2756in.)

0.50 : 83.420 ~ 83.450mm (3.2882 ~ 3.2881in.)

Cylinder Honing

Only a scored or scratched cylinder bore must be honed.

1. Measure the cylinder bores.
If the block is to be reused, hone the cylinders and remeasure the bores.
2. Hone the cylinder bores with honing oil and a fine stone. Do not use stones that are worn or broken.
3. When honing is complete, thoroughly clean the engine block of all metal particles. Wash the cylinder bores with hot soapy water, then dry and oil them immediately to prevent rusting. Never use solvent, it will redistribute the grit on the cylinder walls.
4. If scoring or scratches are still present in the cylinder bores after honing to the service limit, rebore the cylinder block. Some light vertical scoring and scratching is acceptable if it is not deep enough to catch your fingernail and does not run the full length of the bore.

Cylinder Block

EM-63

Reassembly

Balance Shaft

1. Insert the balance driver/driven shafts(A, B) in the carrier.

NOTICE

There are the identification marks (DR, DN) on the shafts(A, B) and the carrier(C).

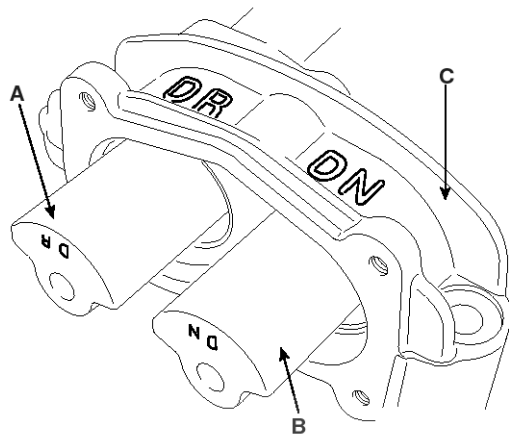

ACIE141A

2. Install the balance shaft driver/driven gears(A, B).

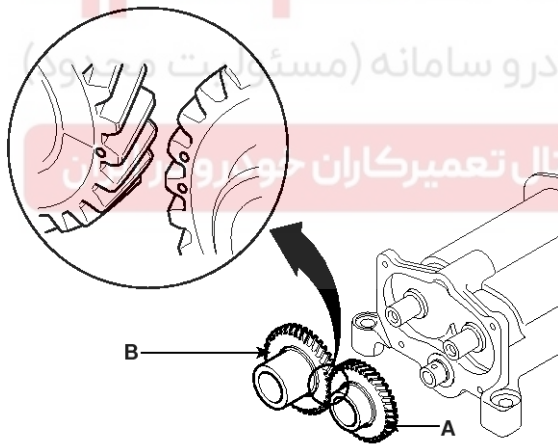

ACIE142A

NOTICE

Confirm the gear marks.

3. Install the balance shaft carrier rear cover(B).

Tightening torque

8 ~ 12N.m (80 ~ 120kgf.m, 5.90 ~ 8.85lb-ft)

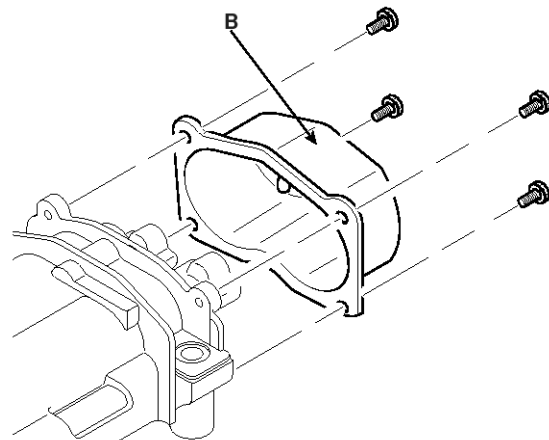

ACIE122A

4. Install the balance shaft gear shim(A).

Tightening torque

8 ~ 12N.m (80 ~ 120kgf.m, 5.90 ~ 8.85lb-ft)

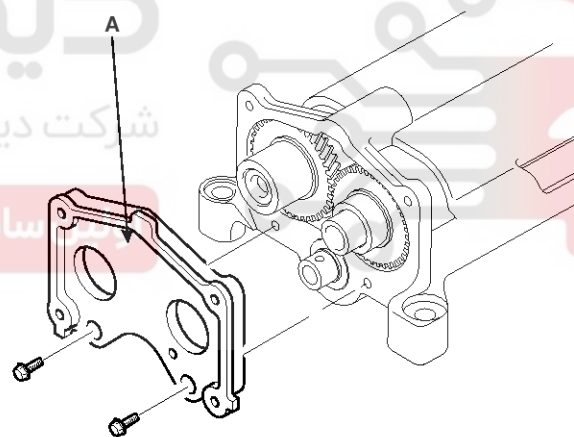

ACIE125A

EM-64

Engine Mechanical System

5. Install the balance shaft drive gear(A) and the intermediate gear assembly(B).

Tightening torque

A : 39 ~ 43N.m (390 ~ 430kgf.m, 28.76 ~ 31.72lb-ft)

B : 60 ~ 64N.m (600 ~ 640kgf.m, 44.25 ~ 47.21lb-ft)

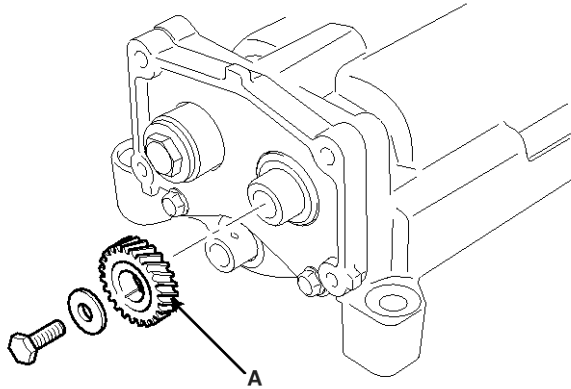

ACIE124A

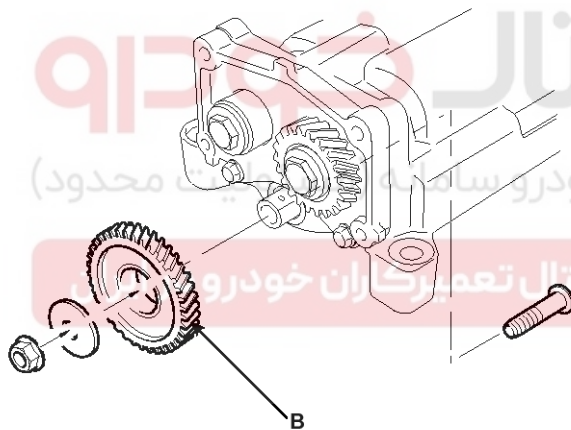

ACIE123A

NOTICE

Confirm the gear marks.

6. Tighten the balance shaft gear bolts with plain washers.

To use a vice(A) as shown below will make the tightening work much easier.

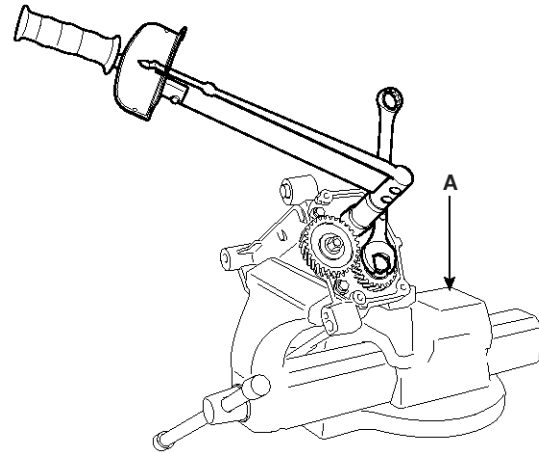

LCIF038A

7. Install the balance shaft carrier front cover(A).

Tightening torque

8 ~ 12N.m (80 ~ 120kgf.m, 5.90 ~ 8.85lb-ft)

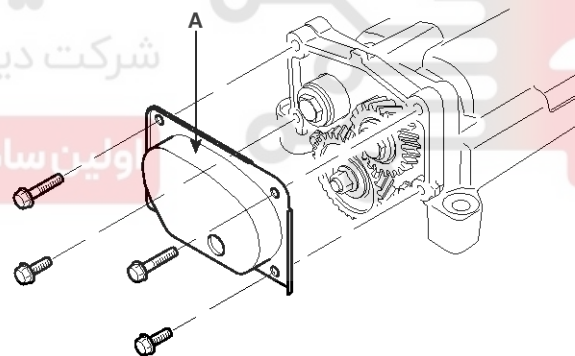

ACIE121A

Cylinder Block

EM-65

Piston

1. Remove the connecting rod caps then install the ring compressor and check that the bearing is securely in place.
2. Position the marks facing the timing belt side of the engine.

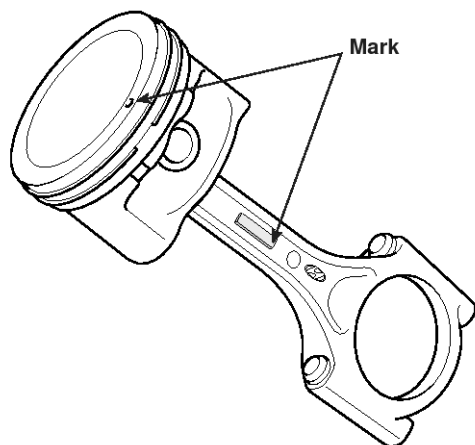

LCIF039A

3. Position the piston in the cylinder and tap it in using the wooden handle of hammer.

Maintain downward force on the ring compressor to prevent the rings from expanding before entering the cylinder bore.

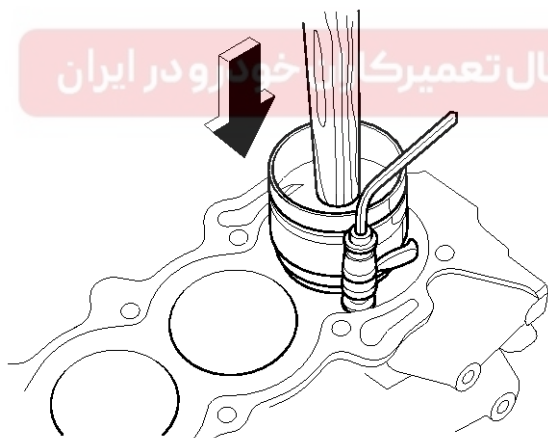

ACIE146A

4. Stop after the ring compressor pops free, and check the connecting rod-to-crank journal alignment before pushing the piston into place.
5. Check the connecting rod bearing clearance with plastigauge.
6. Apply engine oil to the bolt threads, then install the rod caps with bearings.

Crankshaft And Balancer

1. Install the oil jets, tightening the hexagon socket head bolts with the torque 9 ~ 13Nm (98 ~ 130kgf.cm, 6.61 ~ 9.59lb.ft)
2. Apply a coat of engine oil to the main bearings.
3. Install the bearing halves in the engine block.
4. Hold the crankshaft so rod journal No. 2 and rod journal No. 3 are straight up.
5. Lower the crankshaft into the block.
6. Install the bearing halves in the bed plate after applying a coat of engine oil.
7. Install the bed plate(C) to the engine block. After applying the sealant (LOCTITE 5205, DREIBOND 5105 or HYLOMAR 3000).

Tightening torque

15mm(B)

28 ~ 32N.m + (280 ~ 320kgf.m, 20.65 ~23.60lb-ft) + 120°

12mm(A)

33.7 ~ 37.7N.m (337 ~ 377kgf.m, 24.9 ~27.8lb-ft)

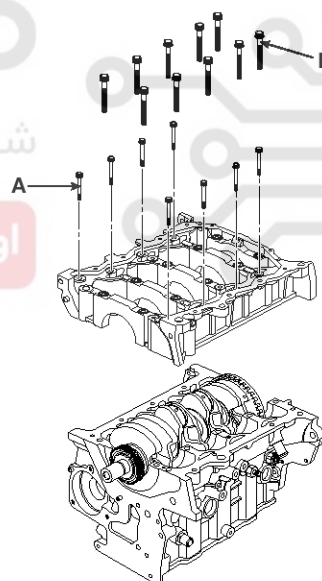

ACIE117A

EM-66

Engine Mechanical System

8. Rotate the crankshaft clockwise to be seated properly.
9. Check the main bearing clearance with plastigauge.
10. Install the piston and connecting rod assemblies.
 - a. Apply coat of engine oil to the connecting rod bearings.
 - b. Install the bearing halves in the connecting rods.
 - c. Insert the assemblies into the cylinder bores.
 - d. Install the connecting rod caps and bolts finger tight
 - e. Rotate the crankshaft clockwise, seat the journals into connecting rod No.2 and connecting rod No.3. Install the connecting rod caps and bolts finger tight. Install caps so the bearing recess is on the same side as the recess in the rod.
 - f. Check the connecting rod bearing clearance with plastigauge.
 - g. Apply engine oil to the bolt threads, then install the rod caps within bearings and torque the bolts to 25N.m + 90° (250kgf.cm + 90°, 18.44lb-ft + 90°).
11. Using the SST(09231-27000), install the crankshaft oil seal(A) squarely.

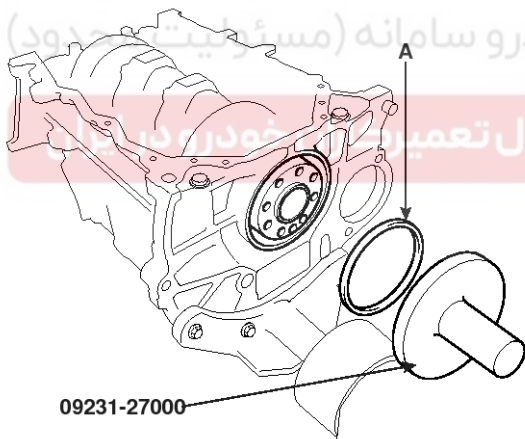

ACIE147A

12. Clean and dry the mating surfaces.
Apply a light coat of oil to the crankshaft and to the lip of the seal.
13. Install the balance shaft assembly(A) onto the bed plate with the bolts (B,C).

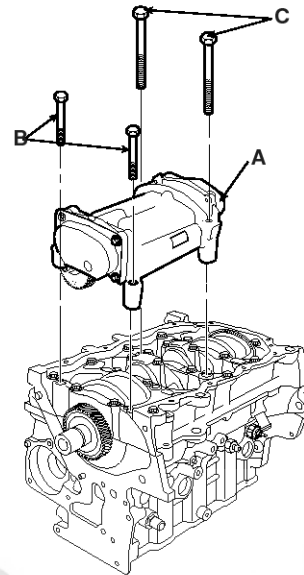

ACIE116A

Tightening torque

53 ~ 57N.m (530 ~ 570kgf.m, 39.09 ~ 42.04lb-ft)

NOTICE

Pay attention to the timing marks on the driver gears of the balance shaft and the crankshaft.

Cylinder Block

EM-67

Installation

1. Clean and dry the oil pump mating surface.
2. Install the oil pump
 - a. Install a new crankshaft oil seal in the oil pump.
 - b. Apply liquid gasket evenly to the block mating surface of the oil pump.

Standard liquid gaskets (or sealants)

DREI BOND 2210, HYLOMAR 101

LOCTITE5900 or equivalent

- Apply liquid gasket in a wide bead : 2.5 ± 0.5 m
 - Apply the liquid gasket without stopping.
 - Assemble the oil pump within 5 minutes after applying.
- c. Grease the lips of the oil seals.
 - d. Align the inner rotor with the crankshaft drive gear and install the oil pump(B).

Tightening torque(A)

20 ~ 27N.m (200 ~ 270kgf.m, 14.75 ~ 19.91lb-ft)

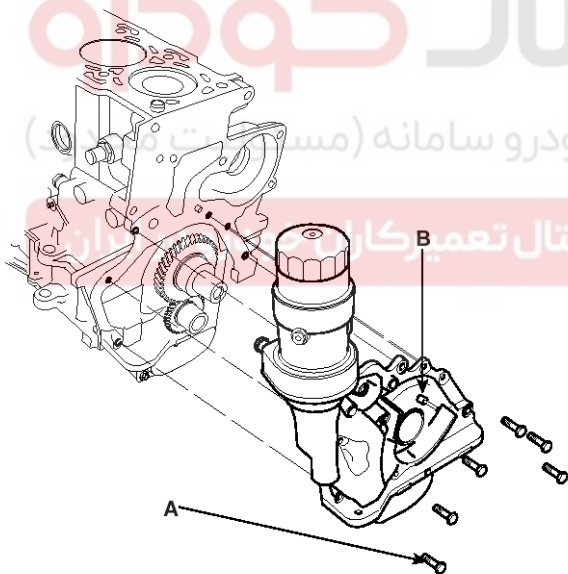

ACIE115A

- e. Clean the excess grease off the crankshaft and check the seals for distortion.

3. Install the crankshaft key(A) on the crankshaft assembly.

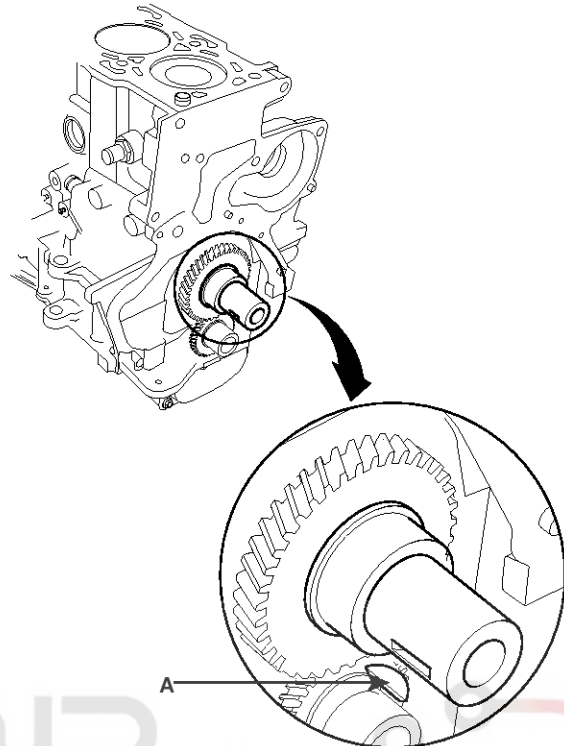

LCIF040A

4. Insert the crankshaft sprocket(B) then tighten the crankshaft bolt(A).

Tightening torque

185 ~ 195N.m (1850 ~ 1950kgf.m, 136 ~ 143.83lb-ft)

NOTICE

Align the timing mark on the sprocket.

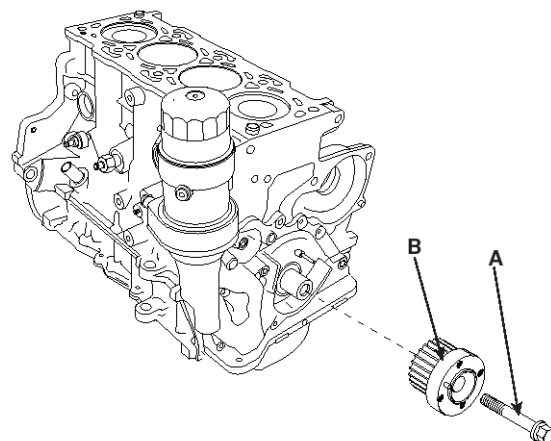

ACIE114A

EM-68

Engine Mechanical System

5. Install the oil screen(A) on the oil pump case(B) and the engineblock.

Tightening torque

Bolt A

10 ~ 12N.m (100 ~ 120kgf.m, 7.37 ~ 8.85lb-ft)

Bolt B

34 ~ 38N.m (340 ~ 380kgf.m, 25.08 ~ 28.03lb-ft)

NOTICE

The bolt B should be tightened after the installation of the bolt A.

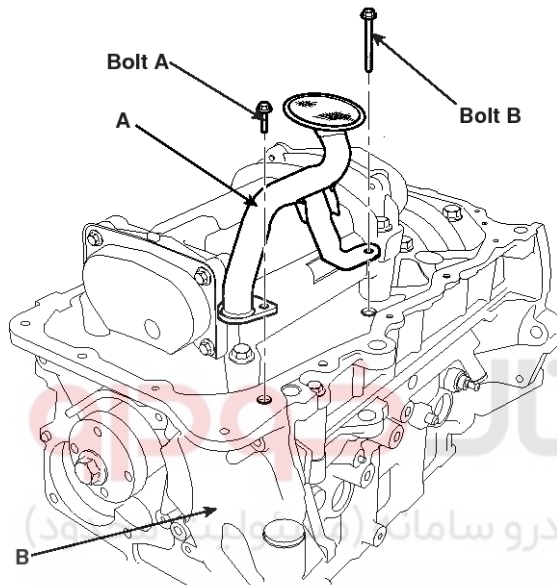

LCIF028A

6. Clean and dry the bed plate and the oil pan mating surfaces.
7. Apply liquid gasket evenly to the bed plate mating surface of the oil pan. Install the oil pan.

NOTICE

- Standard liquid gasket : LOCTITE 5900
- Assemble the oil pan in 5 minutes after applying the liquid gasket.
- Apply liquid gasket in a 3mm wide bead without stopping.
- The clearance between the liquid gasket and the flange inner end should be 2 ~ 3mm.

8. Tighten the bolt in two or three steps. In the final step, tighten all bolts.

Tightening torque

10 ~ 12N.m (100 ~ 120kgf.m, 7.38 ~ 8.85lb-ft)

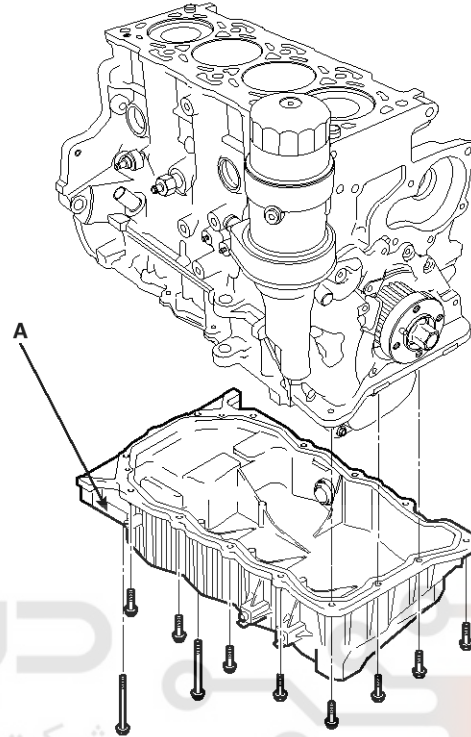

ACIE112A

NOTICE

After installing the oil pump assembly and the oil pan, remove the oil cooler and fill the 50cc engine oil.

Cylinder Block

EM-69

9. Install the water pump.

Tighten torque

Bolt A

48 ~ 52N.m (480 ~ 520kgf.m, 35.40 ~ 38.35lb-ft)

Bolt B

10 ~ 12N.m (100 ~ 120kgf.m, 7.37 ~ 8.85lb-ft)

10. Install the auto-tensioner(A).

Tightening torque

Pivot bolt(B)

50 ~ 55N.m (500 ~ 550kgf.m, 36.88 ~ 40.57lb-ft)

Stop bolt

10 ~ 12N.m (100 ~ 120kgf.m, 7.38 ~ 8.85lb-ft)

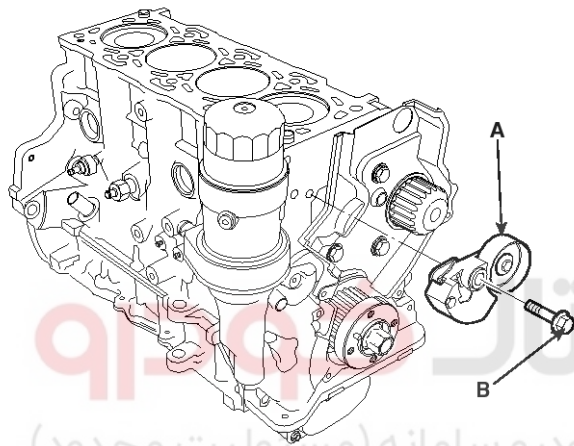

ACIE109A

11. Install the air compressor(A). (See HA group - compressor)

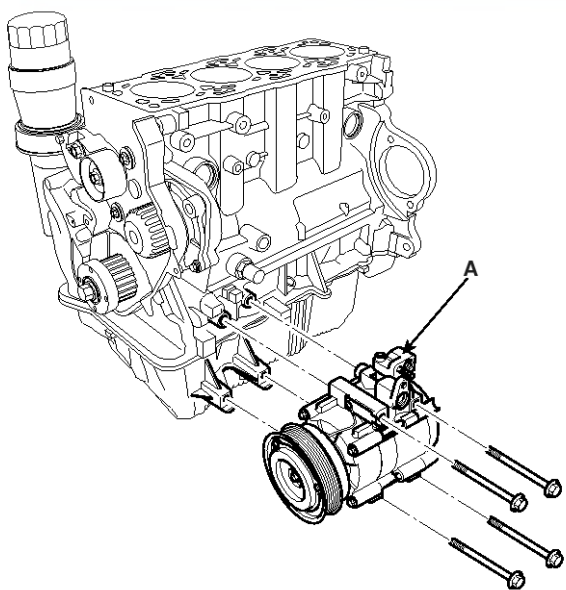

ACIE108A

12. Install the water inlet pipe assembly(A), tightening the bolt(B).

Tightening torque

20 ~ 25N.m (200 ~ 250kgf.m, 14.75 ~ 18.44lb-ft)

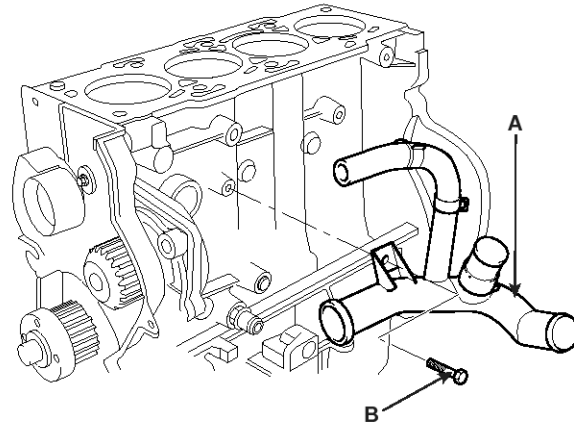

ACIE107A

13. Install the power steering pump mounting bracket assembly(A).

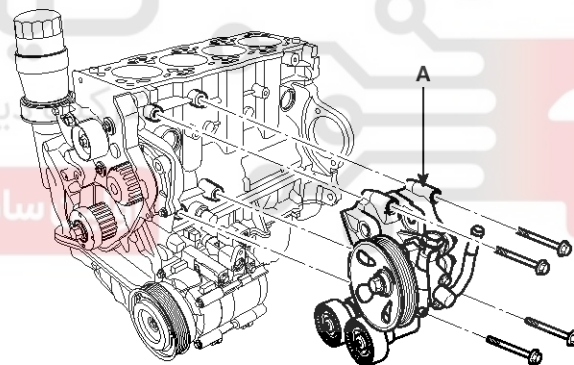

ACIE106A

EM-70

Engine Mechanical System

14. Install the heater and oil cooler return pipe(A) assembly.

Tightening torque

Rear side bolt and left side bolt(C, D)

20 ~ 25N.m (200 ~ 250kgf.m, 14.75 ~ 18.44lb-ft)

Right side bolt(E)

8 ~ 10N.m (80 ~ 100kgf.m, 5.90 ~ 7.38lb-ft)

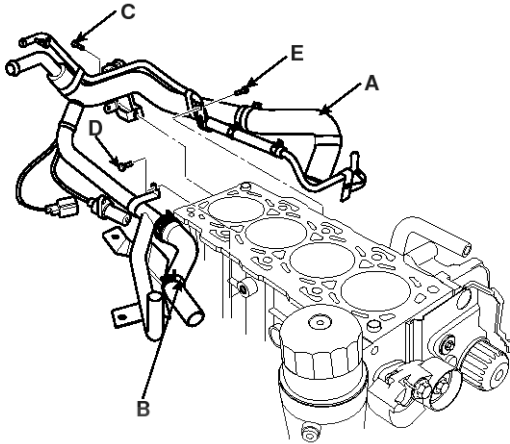

ACIE104A

15. Install the Crankshaft Position Sensor(CKP)(A) and the oil pressure switch(B).

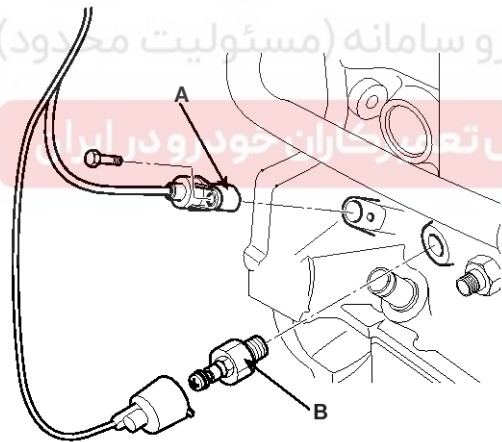

ACIE103A

16. Install the cylinder head assembly.

17. Install the intake/exhaust manifold assemblies.

18. Install the oil level gauge(A).

Tightening torque

10 ~ 12N.m (100 ~ 120kgf.m, 7.38 ~ 8.85lb-ft)

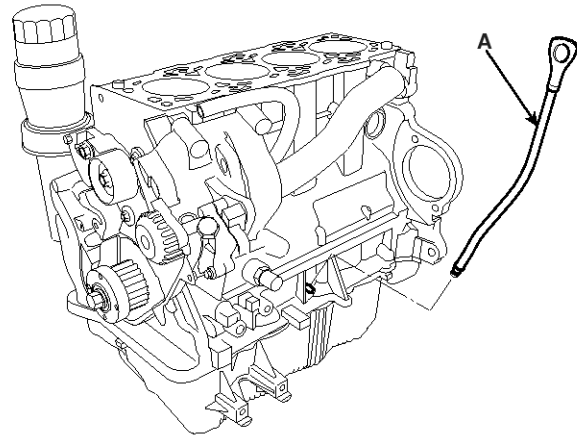

ACIE102A

19. Install the timing belt assembly.

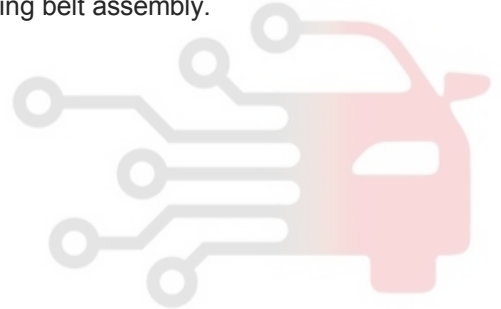

Cooling System

EM-71

Cooling System

Components

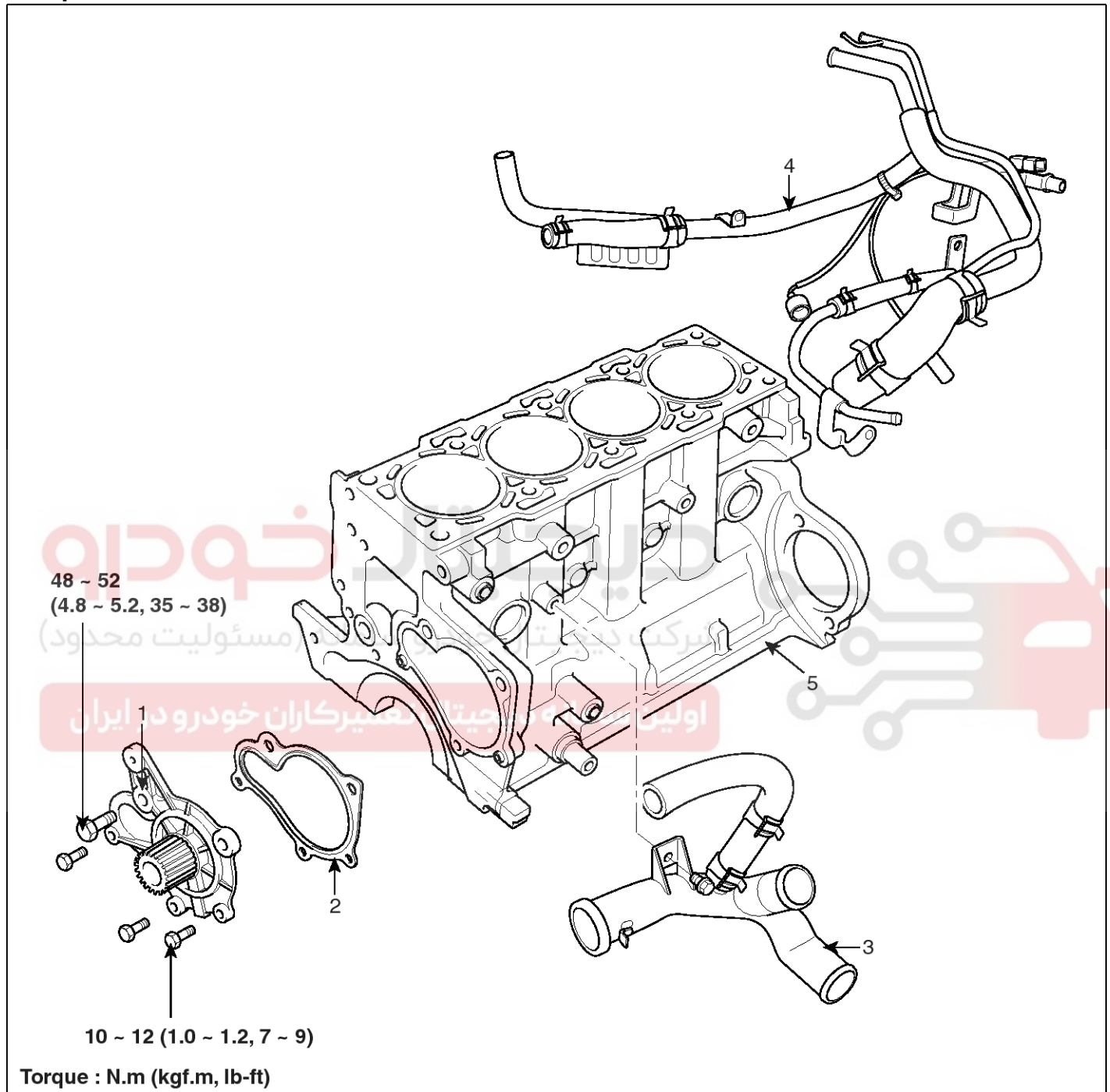

SMGM19017L

1. Coolant pump

2. Gasket

3. Coolant inlet pipe

4. Coolant hose & pipe

5. Cylinder block

EM-72

Engine Mechanical System

Inspection**Thermostat**

Replace the thermostat if it is open at room temperature.

1. Suspend the thermostat in a container of water.
Do not let the thermometer touch the bottom of the hot container.

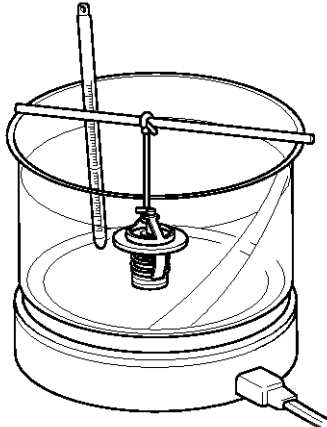

ACIE153A

2. Heat the water and check the temperature with the thermometer. Check the temperature at which the thermostat first opens, and at which it is fully open.
3. Measure the lift height of the thermostat when it is fully open.

STANDARD THERMOSTAT

Lift height : above 8.0mm (0.31in.)

Starts opening: $85 \pm 1.5^{\circ}\text{C}$ ($185 \pm 34.7^{\circ}\text{F}$)

Fully open : 100°C (212°F)

Replacement**Water Pump**

1. Drain the engine coolant after removing drain plug(A).

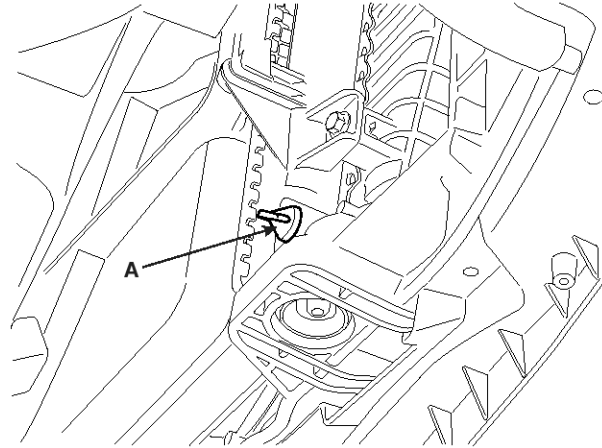

SNFEM6001D

2. Remove the timing belt.
3. Remove the timing belt rear cover(A).

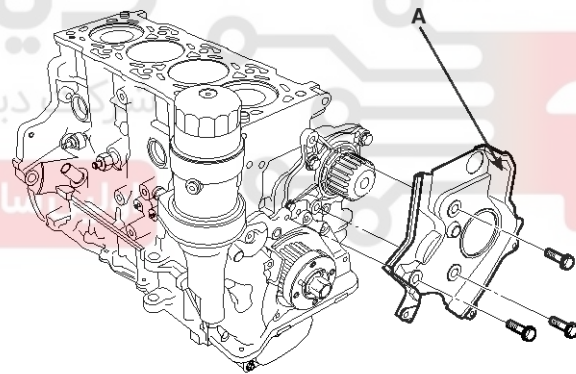

ACIE110A

Cooling System

EM-73

4. Remove the water pump(A) with the gasket(B) by removing four bolts. (One bolt A and three bolt B)

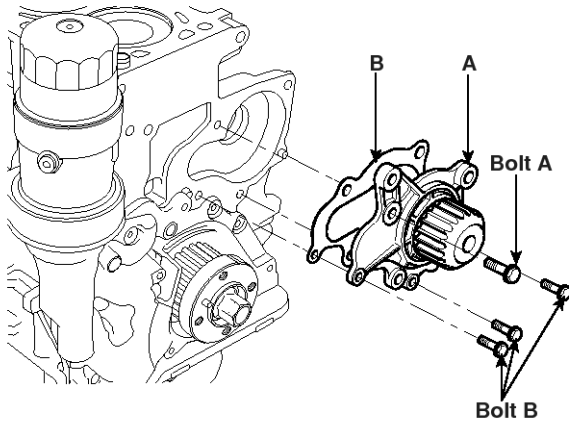

LCIF027A

5. Inspect, repair and clean the mating surface on the engine block.
6. Install the water pump, with a new gasket in the reverse order of removal.

Tightening torque

For timing belt rear cover

7.8 ~ 11.8N.m (78 ~ 1180kgf.cm, 5.75 ~ 8.70lb-ft)

For water pump

Bolt A : 48 ~ 52N.m (480 ~ 520kgf.cm, 35.40 ~ 38.40lb-ft)

Bolt B :

10 ~ 12N.m (100 ~ 120kgf.cm, 7.38 ~ 8.85lb-ft)

7. Clean the spilled engine coolant.

Radiator

1. Remove the under cover(A).

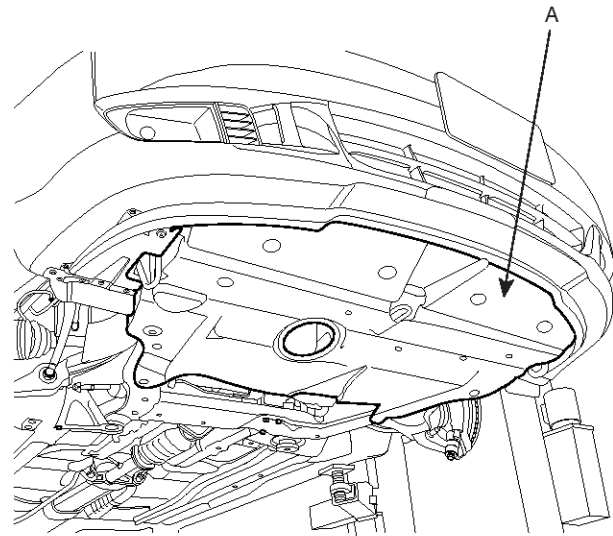

KMRE009H

2. Drain the engine coolant after removing drain plug(A). Remove the radiator cap to speed draining.

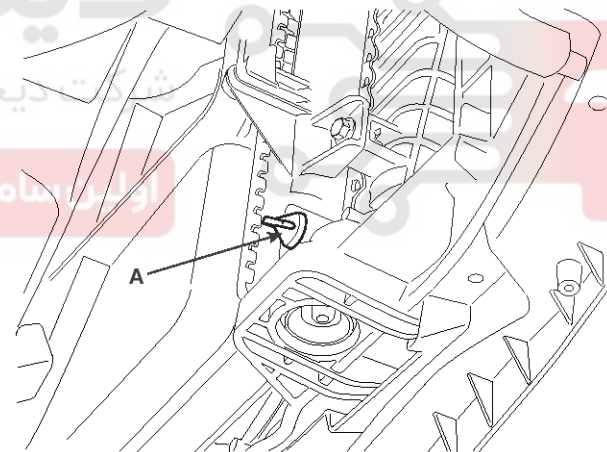

SNFEM6001D

EM-74

Engine Mechanical System

3. Remove the air duct(A).

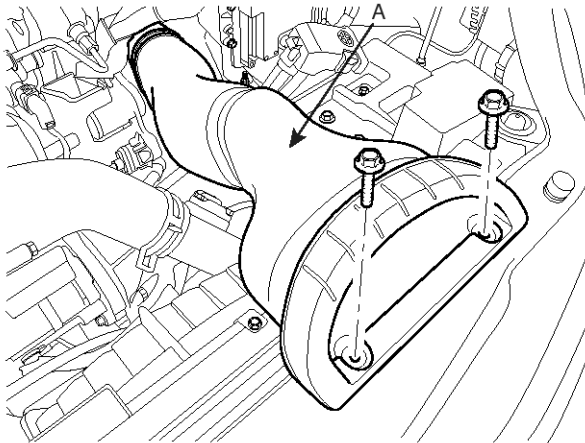

SMGMT6101D

4. Remove the radiator upper hose(A) and the coolant bleed hose(B).

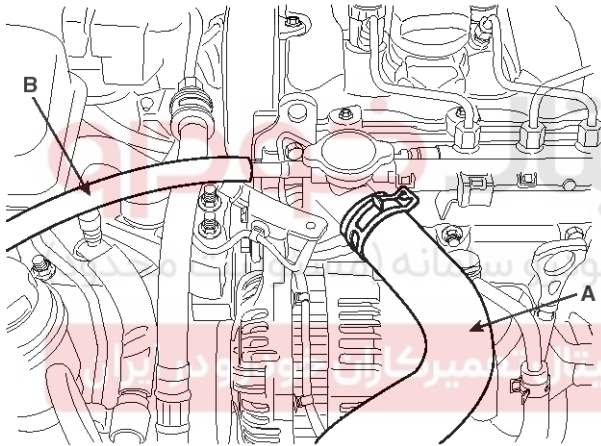

SNFEM6002D

5. Remove the intercooler intake hose(A).

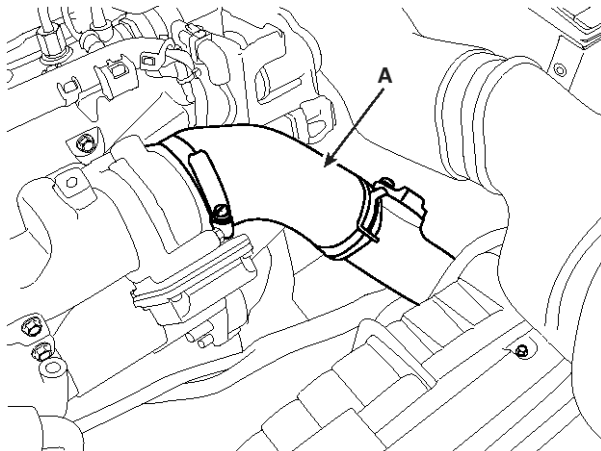

SMGEM6008D

6. Remove the radiator lower hose(A) and the intercooler lower pipe(B).

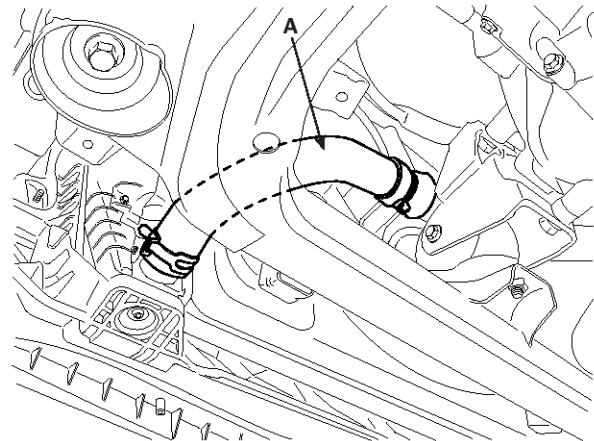

SNFEM6003D

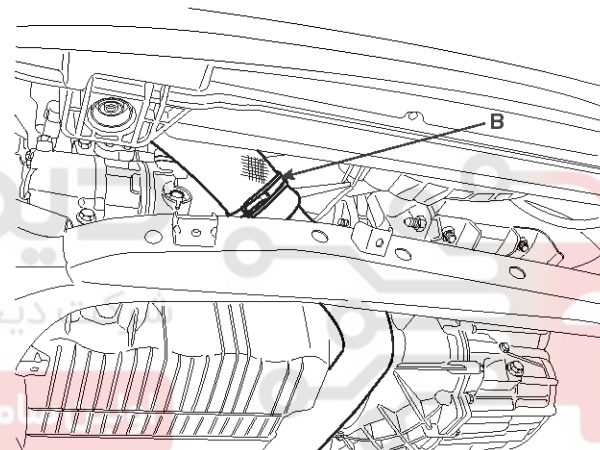

SNFEM6005D

7. Remove the cooling fan motor connector(A).

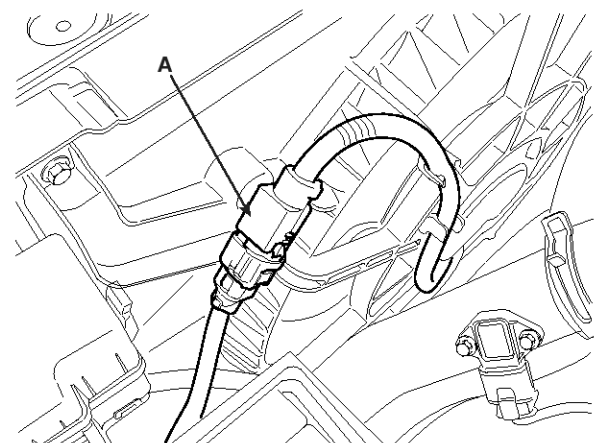

SNFEM6004D

Cooling System

EM-75

8. Remove the glow relay box(A) form bracket.

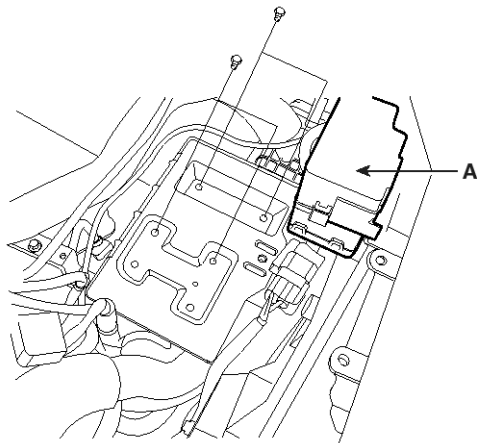

SNFEM6029D

9. Remove the radiator bracket(A,B) and the mounting bolts.

LH upper

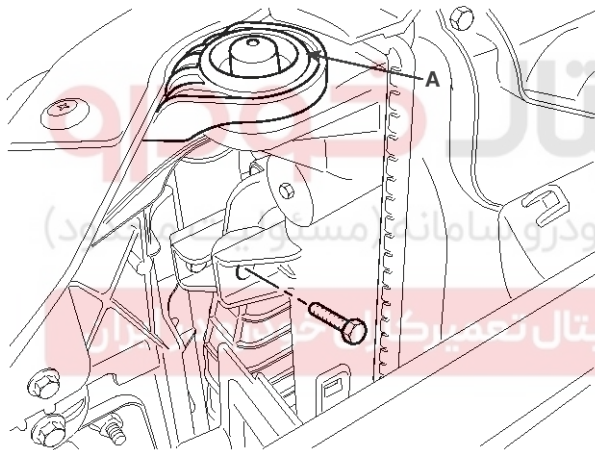

SNFEM6007D

LH lower

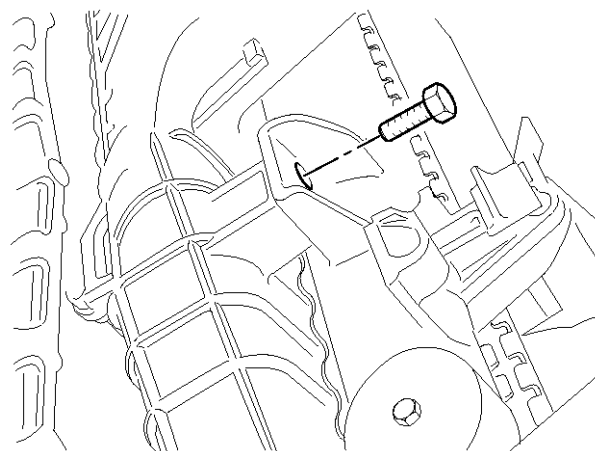

SNFEM6009D

RH upper

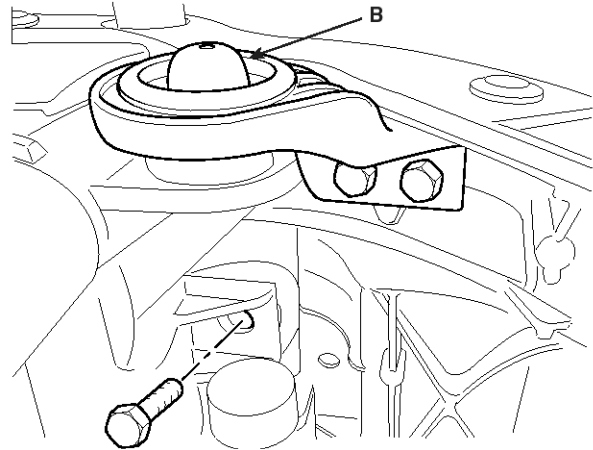

SNFEM6008D

RH upper

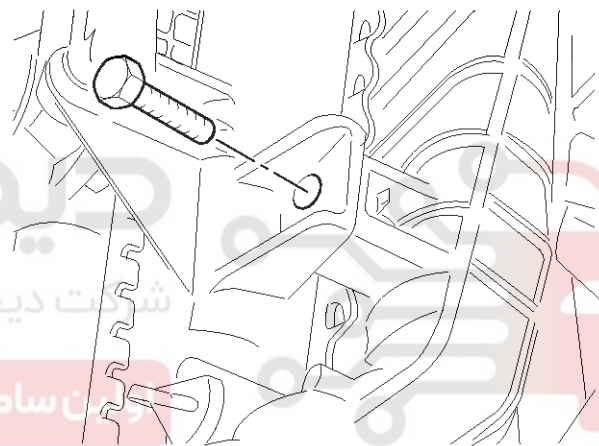

SNFEM6010D

10. Pull the radiator upper from the engine room.

EM-76

Engine Mechanical System

Thermostat

1. Drain the engine coolant.
2. Remove the radiator upper hose(A) and coolant bleeder hose(B).

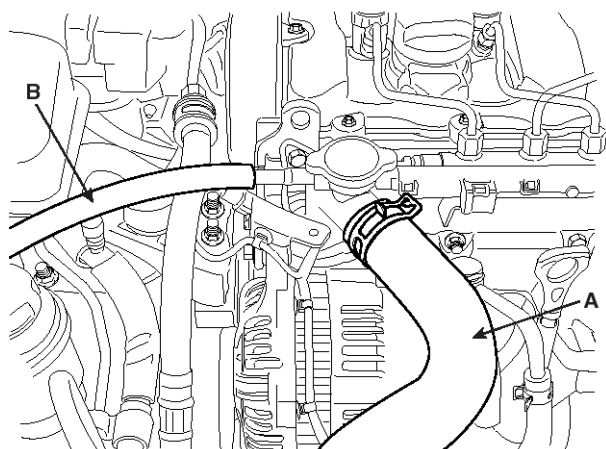

SNFEM6002D

3. Remove the coolant inlet fitting.
4. Remove the thermostat(A).

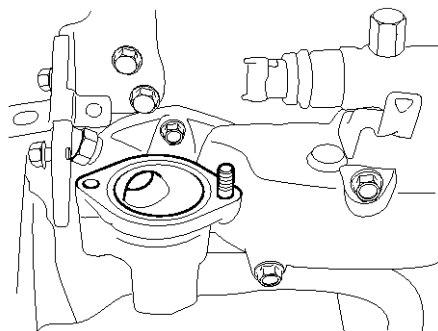
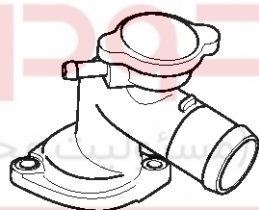

SNFEM6030D

Installation

Radiator

1. Install the engine room from radiator.
2. Install the radiator bracket(A,B) and the mounting bolts.

LH upper

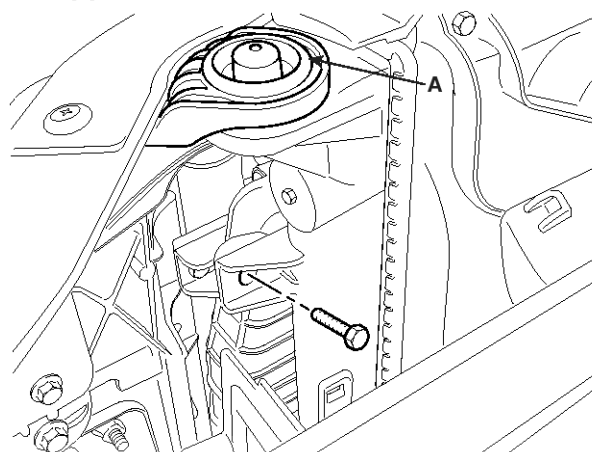

SNFEM6007D

LH lower

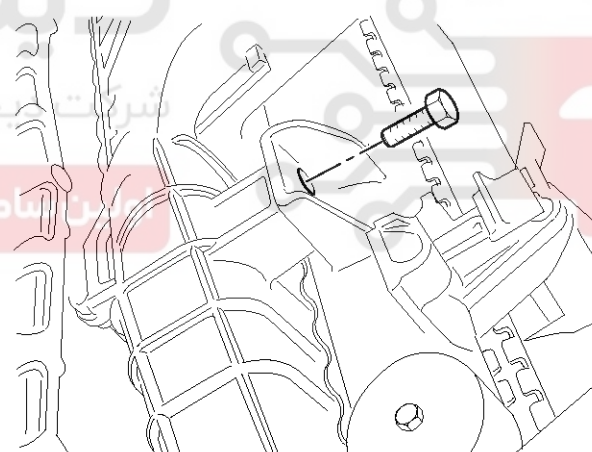

SNFEM6009D

Cooling System

EM-77

RH upper

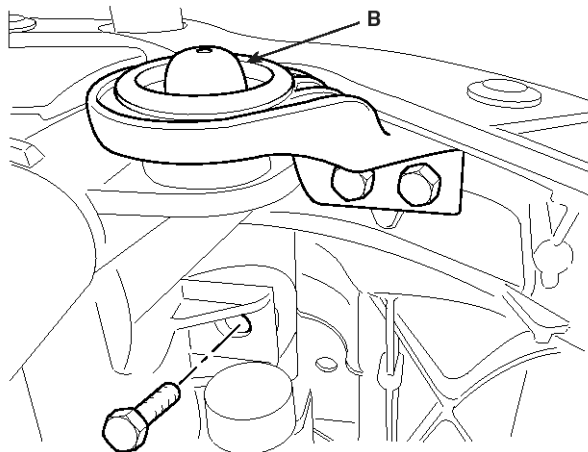

SNFEM6008D

RH lower

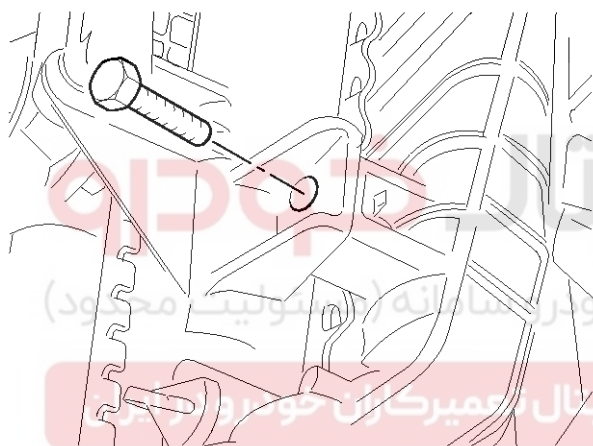

SNFEM6010D

3. Install the cooling fan motor connector(A).

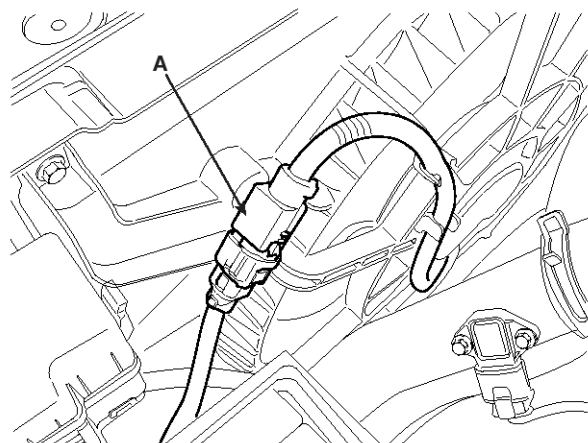

SNFEM6004D

4. Install the glow relay box(A) form bracket.

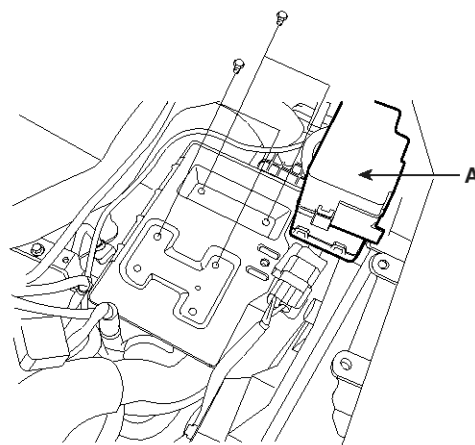

SNFEM6029D

5. Install the radiator lower hose(A) and the intercooler lower pipe(B).

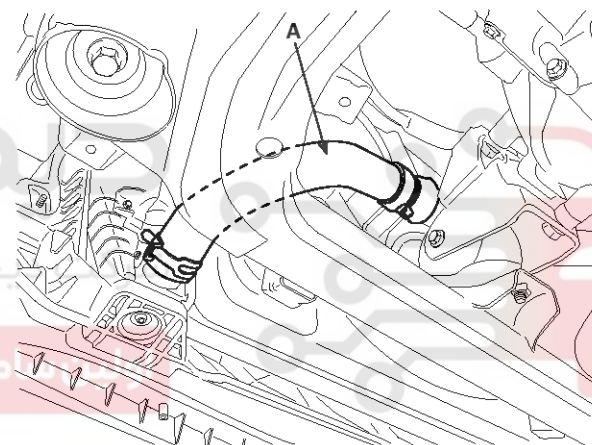

SNFEM6003D

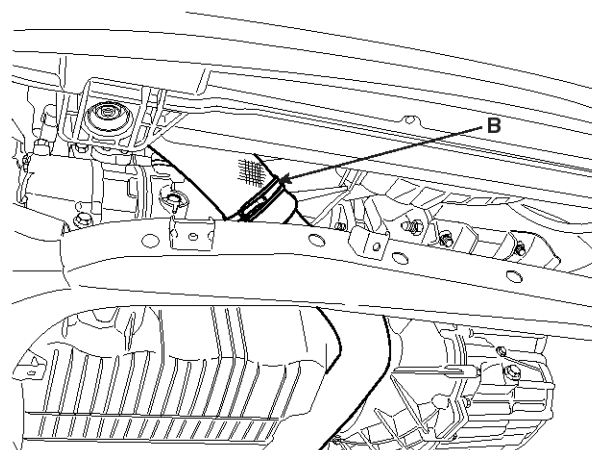

SNFEM6005D

EM-78

Engine Mechanical System

6. Install the intercooler intake hose(A).

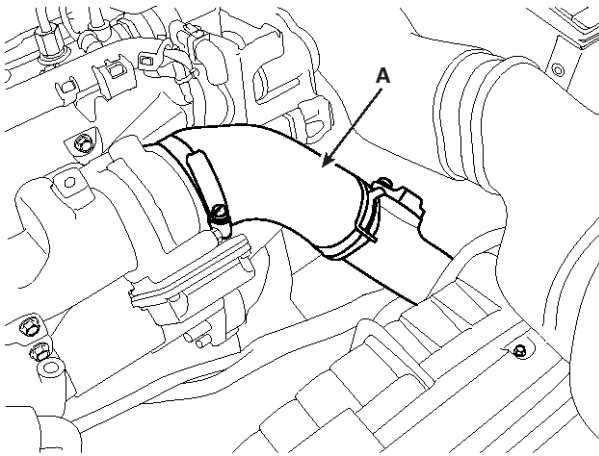

SMGEM6008D

7. Install the radiator upper hose(A) and the coolant bleed hose(B).

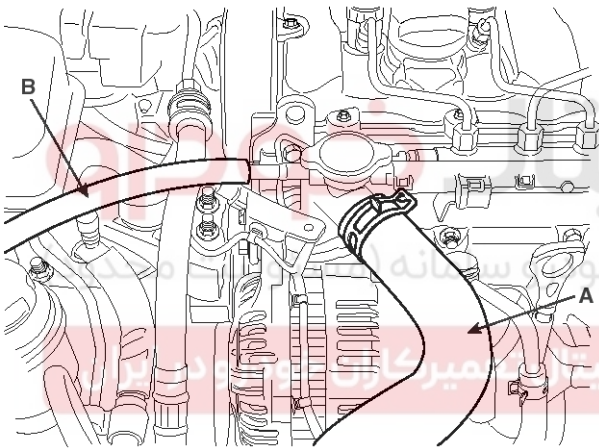

SNFEM6002D

8. Install the air duct(A).

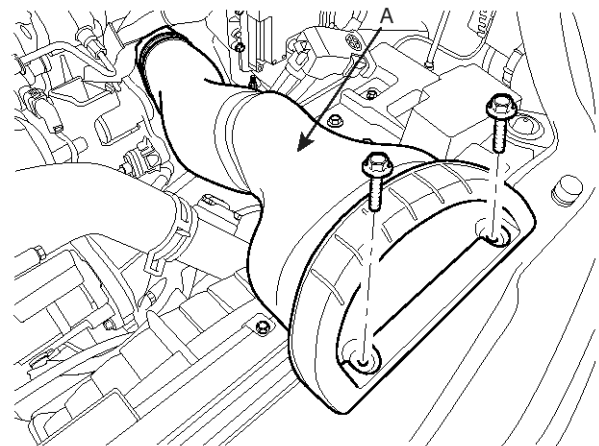

SMGMT6101D

9. Install the under cover(A).

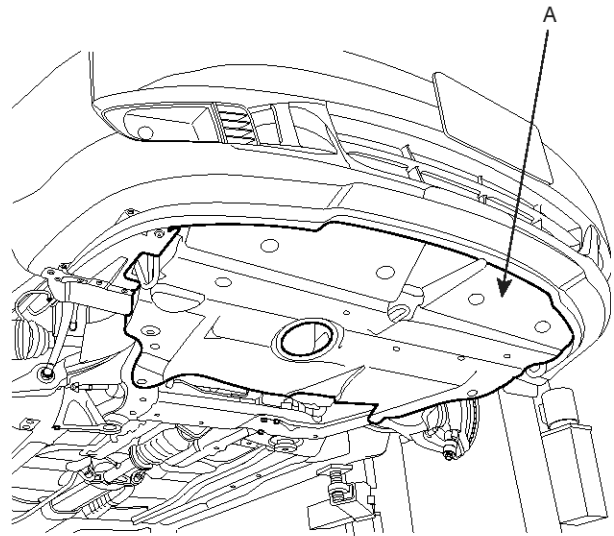

KMRE009H

10. Refill the coolant.

Lubrication System

EM-79

Lubrication System

Components

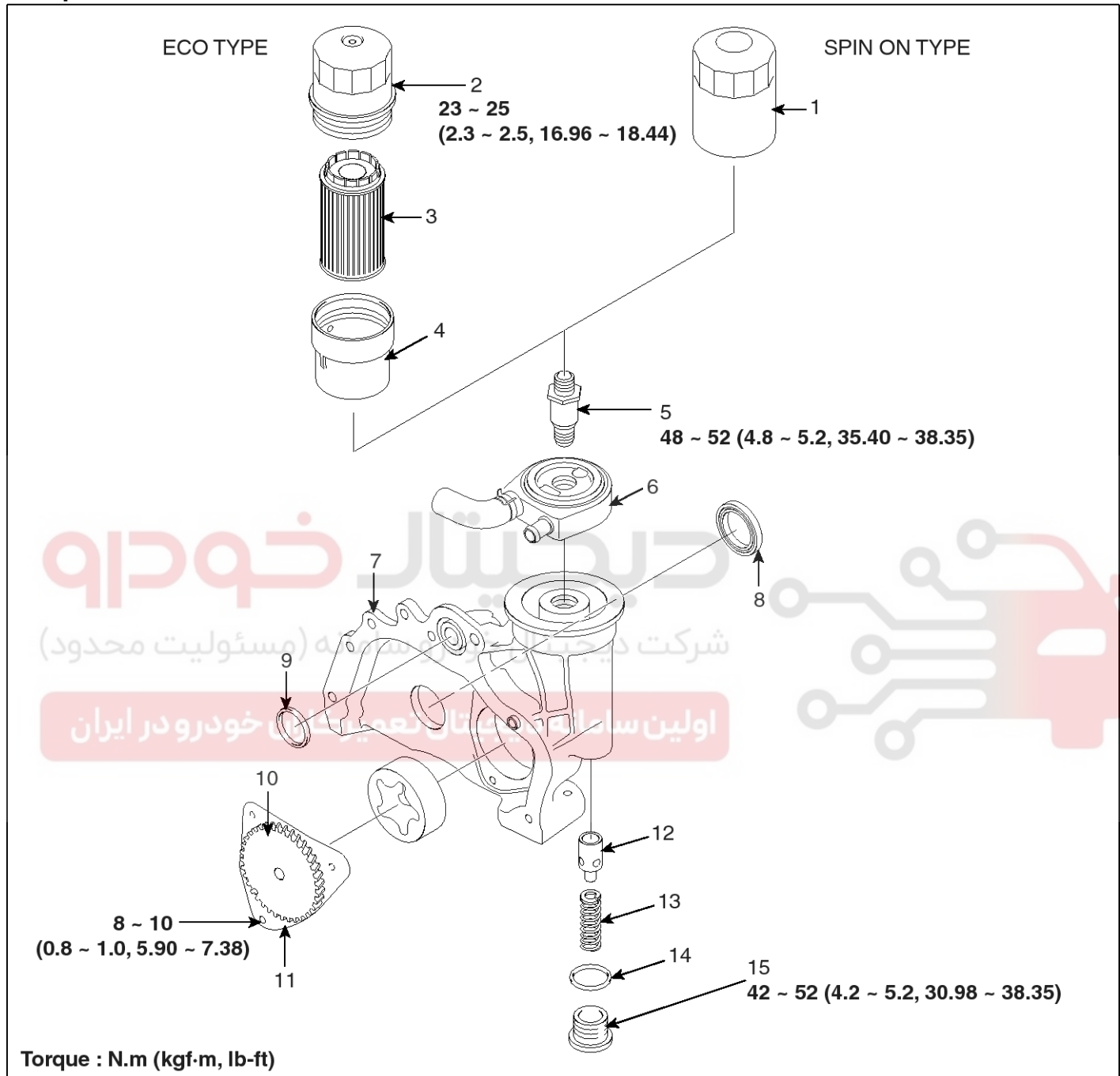

SMGM19018L

- | | | |
|--------------------------|-------------------------|-----------------------|
| 1. Oil filter assembly | 6. Oil cooler | 11. Oil pump cover |
| 2. Oil filter upper cap | 7. Oil pump housing | 12. Relief plunger |
| 3. Oil filter element | 8. Oil seal | 13. Relief spring |
| 4. Oil filter lower case | 9. O-ring | 14. Relief cap washer |
| 5. Oil filter fitting | 10. Oil pump drive gear | 15. Relief cap |

EM-80

Engine Mechanical System

Replacement Engine Oil Filter

NOTICE

There are two kinds of oil filters. One is for Eurpe LHD and the orther is for the rest area except Eurpe LHD (Left Hand Drive).

ECO TYPE :

1. Remove the oil filter upper cap from lower case with SST(09263-2E000 the oil filter wrench.).
2. Inspect the threads and rubber packing. Wipe off the seat on the oil pump assembly, then apply a light coat of oil to the oil pump assembly upper cap packing.
3. Install the new oil filter by hand to the upper cap.
4. After the rubber seal seats, tighten the oil filter clockwise with the special tool.

SPIN ON TYPE :

1. Remove the oil filter(A) with the SST(09263-27000, the oil filter wrench).

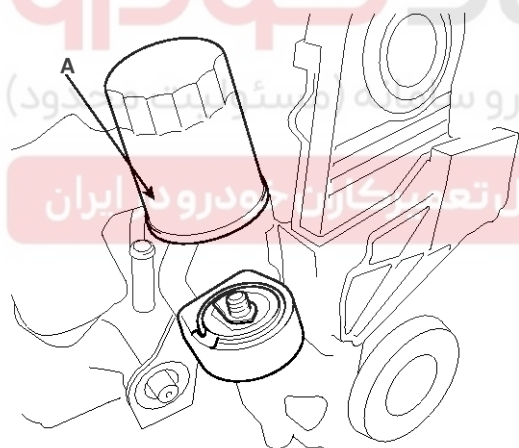

ACIE158A

2. Inspect the threads and the packing on the apply a light coat of oil new filter. Wipe off the seat.
3. Install the new oil filter by hand.
4. After the packing seats, tighten the oil filter clockwise with the SST(09263-27000).

Engine Oil

NOTICE

Under normal conditions, the oil filter should be replaced at every other oil change. Use severe conditions, the oil filter should be replaced at each oil change.

1. Warm up the engine.
2. Remove the drain bolt, and drain the engine oil.
3. Reinstall the drain bolt with a new washer.

Tightening torque

35 ~ 45N.m (3.5 ~ 4.5kgf.m, 25.8 ~ 33.2lb-ft)

4. Refill with the recommended oil.

Oil quantity

Total : 6.6 L (6.97US qt, 5.80 Imp qt)

Oil pan : 5.4 L (5.70 US qt, 4.74 Imp qt)

Drain and refill including oil filter : 5.9 L (6.23 US qt, 5.18 Imp qt)

Lubrication System

EM-81

Selection Of Engine Oil

ACEA classificaton : C3 (with CPF), B4 (without CPF)

SAE viscosity grades : Refer to the recommended SAE viscosity number

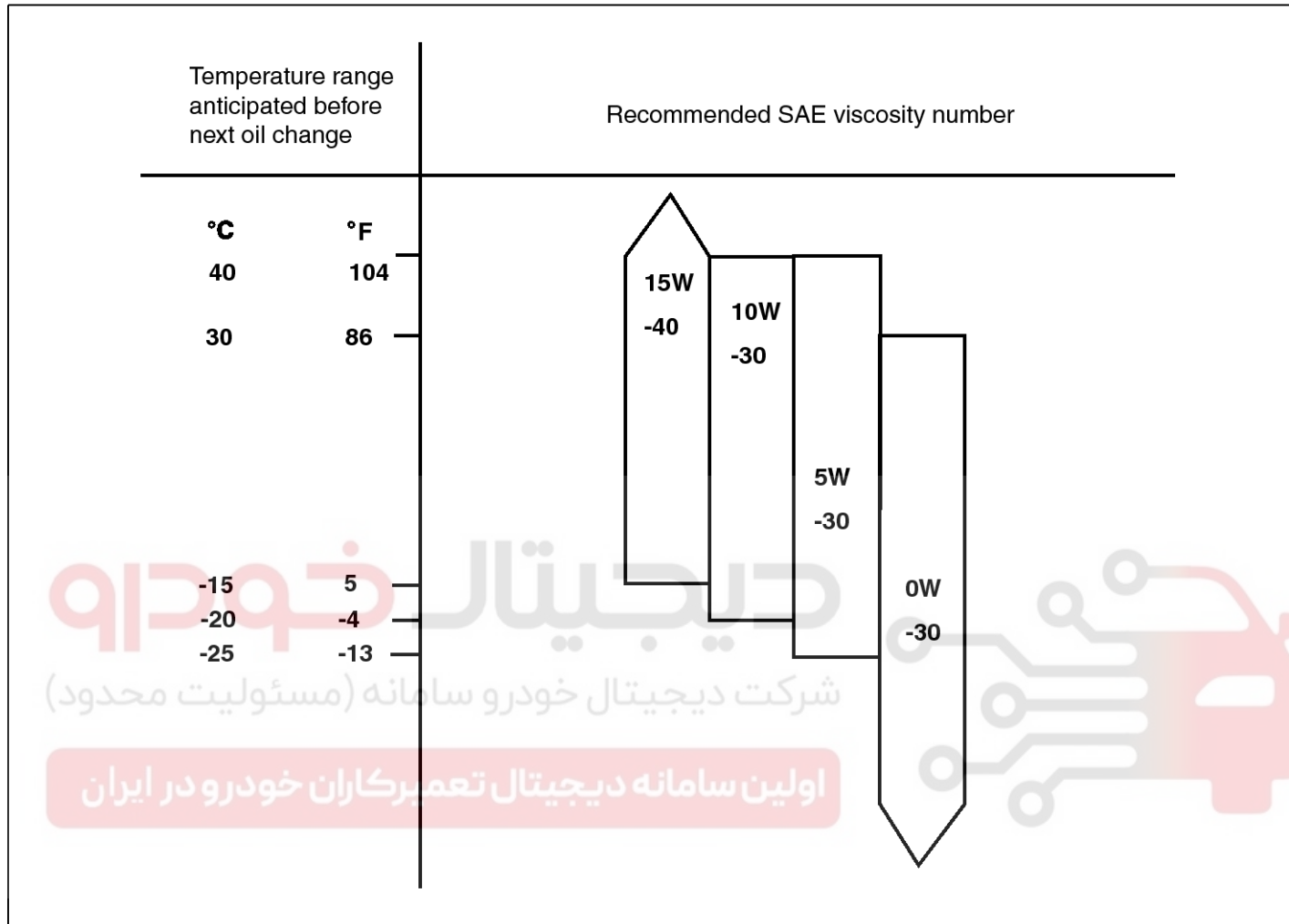

SCMEM7200L

NOTICE

For best performance and maximum protection of all types of operation, select only those lubricants which :

1. Satisfy the requirement of the ACEA classification.
2. Have proper SAE grade number for expected ambient temperature range.
 - Lubricants that do not have both an SAE grade number and ACEA service classification on the container should not be used.
 - The ACEA certified engine oil is required as a service engine oil. Only in case that ACEA certified engine oil is not available, the API certified engine oil (API CH-4 or above) is allowed restrictively.
 - For the vehicle equipped with CPF, the service engine oil quality should meet the ACEA C3 grade.

However, oil refill with small amount of ACEA B4 grade between oil change intervals is possible.

EM-82

Engine Mechanical System

Removal
Oil Pump

1. Drain the engine oil.
2. Remove the crankshaft pulley(A).

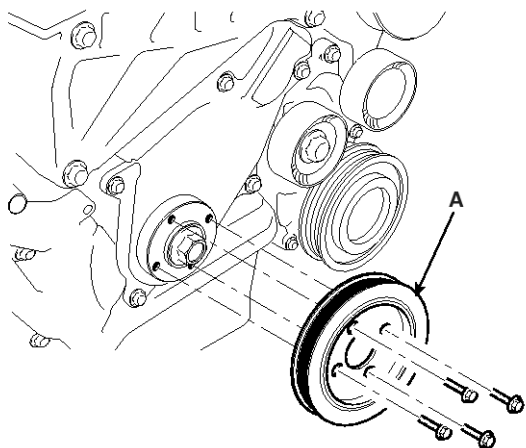

ACIE045A

3. Remove the timing belt assembly.
4. Remove the timing belt tensioner(A).

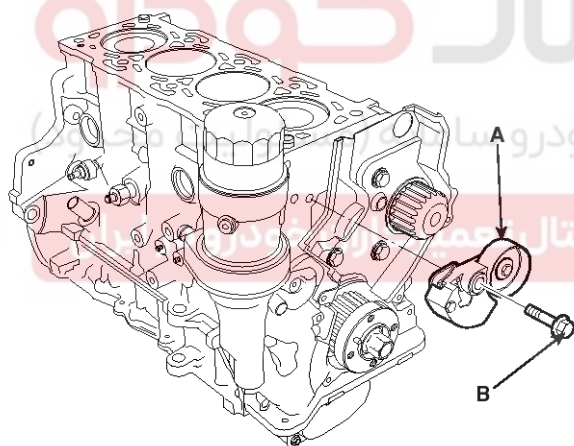

ACIE109A

5. Remove the timing rear cover(A).

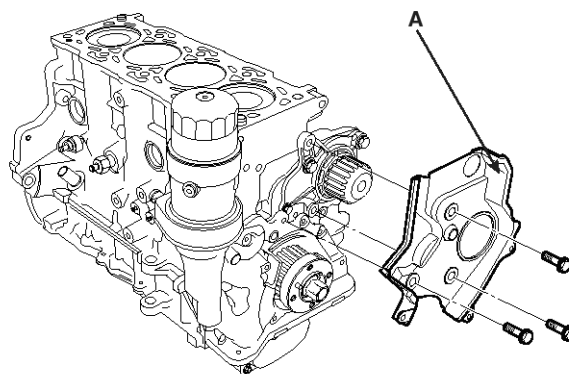

ACIE110A

6. Separate oil pan(A) from the engine block with an oil pan seal cutter.

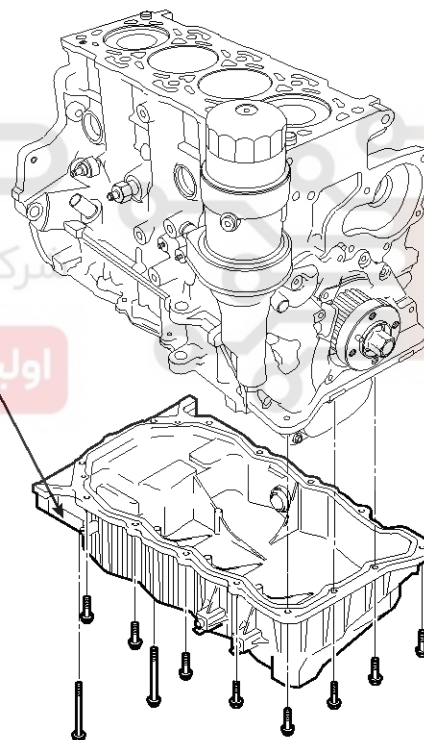

ACIE112A

Lubrication System

EM-83

7. Remove the oil screen.
8. Remove the crankshaft sprocket(B) with bolt(A).

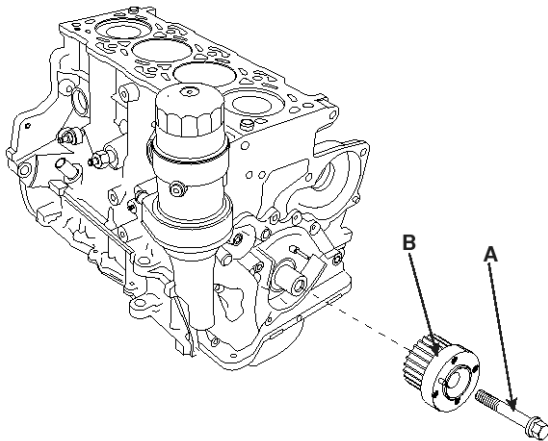

ACIE114A

9. Remove the mounting bolts(A) and the oil pump assembly(B).

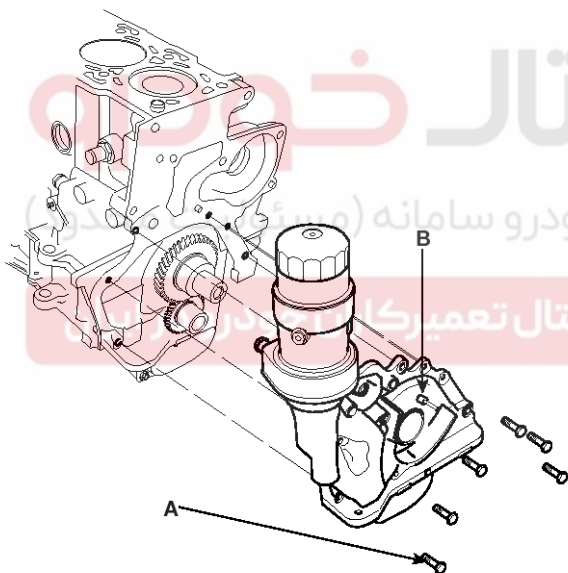

ACIE115A

Disassembly

Oil Pump

1. Remove the three hexagon socket head bolts(A) from the oil pump cover(B).

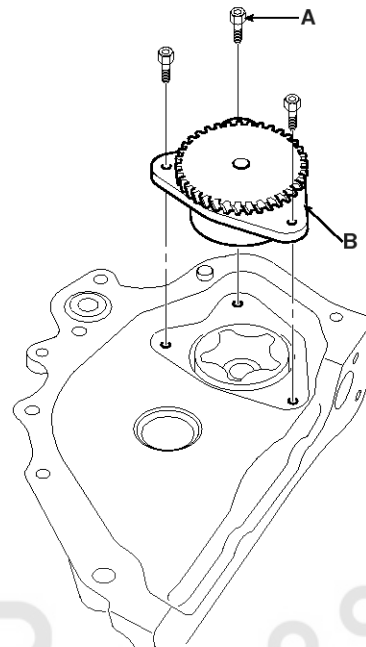

ACIE159A

2. Remove the out rotor from the oil pump case.
3. Remove the old oil seals from the oil pump case.
4. Remove the O ring(A) from the oil pump case.

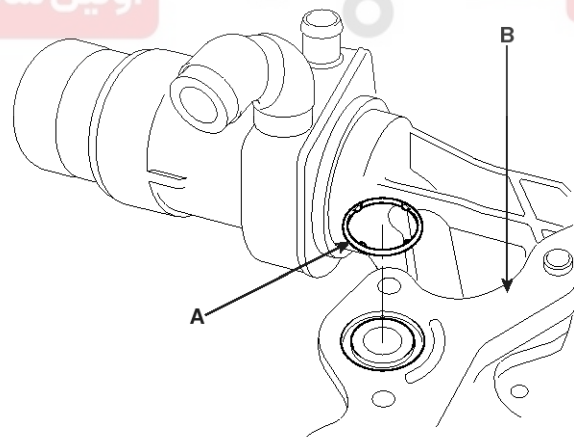

ACIE160A

EM-84

Engine Mechanical System

- Remove the relief cap(A), relief cap washer(B), relief spring(C) and relief plunger(D).

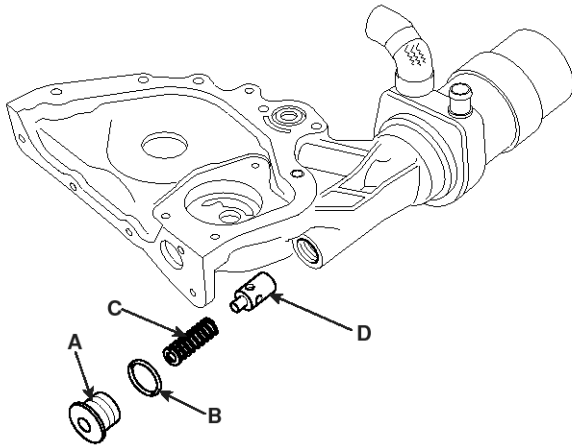

ACIE161A

- Remove the oil filter. Refer to the engine oil filter replacement.
- Remove the oil cooler and hose assembly after separating the oil filter fitting.

Inspection

Oil Pump

- Check the inner-to-outer rotor tip clearance between the inner rotor(A) and outer rotor(B). If the inner-to-outer rotor clearance exceeds the service limit, replace the inner and outer rotors.

Inner Rotor-to-Outer Rotor tip Clearance

Standard (New)

0.12 ~ 0.20mm (0.0047 ~ 0.0079in.)

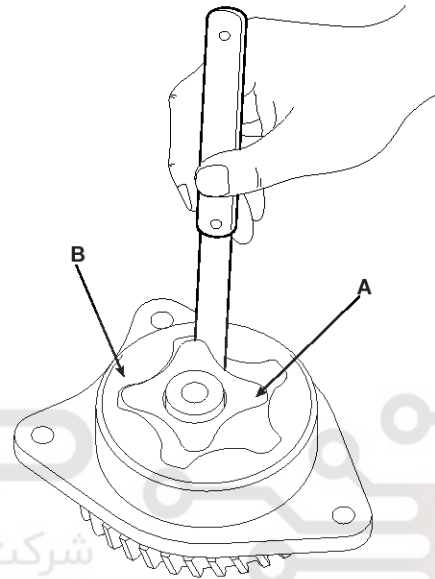

ACIE163A

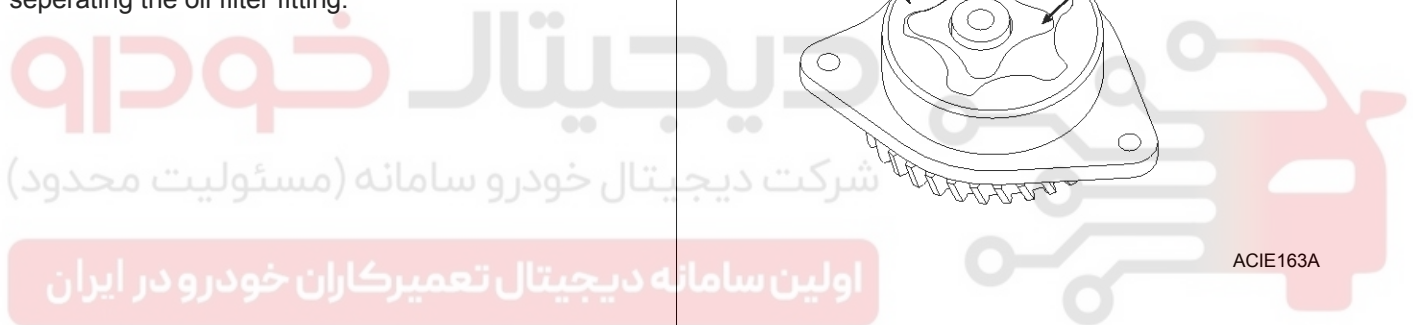

Lubrication System

EM-85

2. Check the housing-to-rotor axial clearance between the rotor and oil pump cover housing. If the housing-to-rotor axial clearance exceeds the service limit, replace the set of inner and outer rotors and/or the pump housing.

Housing-to-Rotor Axial Clearance

Standard (New)

0.020 ~ 0.070mm (0.00079 ~ 0.00276in.)

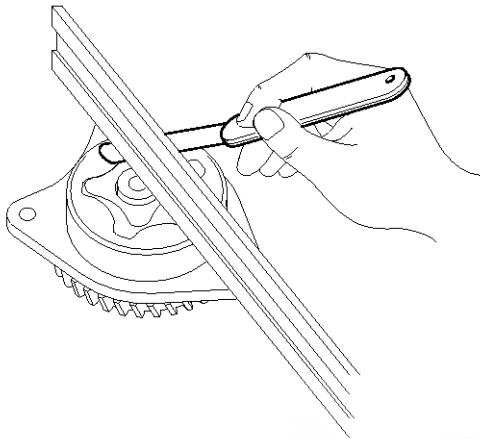

ACIE162A

3. Inspect both rotors and the oil pump cover housing for scoring or other damage. Replace parts if necessary.

Oil Pressure Switch

1. Remove the oil pressure switch from the engine block.
2. Connect a tester (ohm range) between the terminal and the body of the switch to check for continuity. The switch is normal if there is continuity. If there is no continuity, replace the switch.

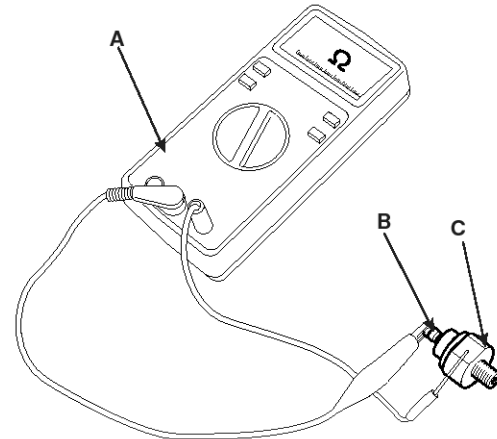

ACIE164A

3. Insert a thin rod in the oil hole of the switch and push it in lightly. The switch is normal if no continuity is detected (infinite resistance on the tester). If there is continuity, replace the switch.

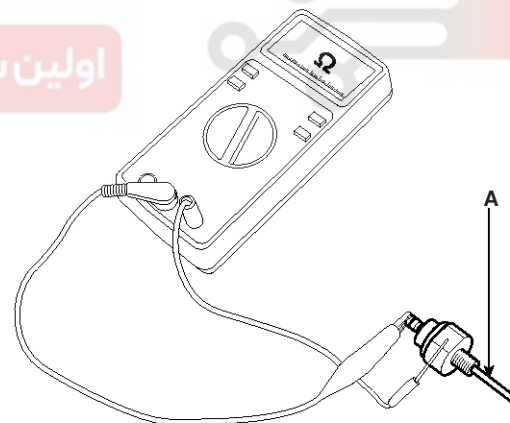

ACIE165A

EM-86

Engine Mechanical System

Reassembly

Oil Pump

1. Insert the relief plunger(D), the relief spring(C) and the relief cap washer(B). Then torque the relief cap(A).

Tightening torque

42 ~ 52N.m (4.2 ~ 5.2kgf.m, 30.98 ~ 38.35lb-ft)

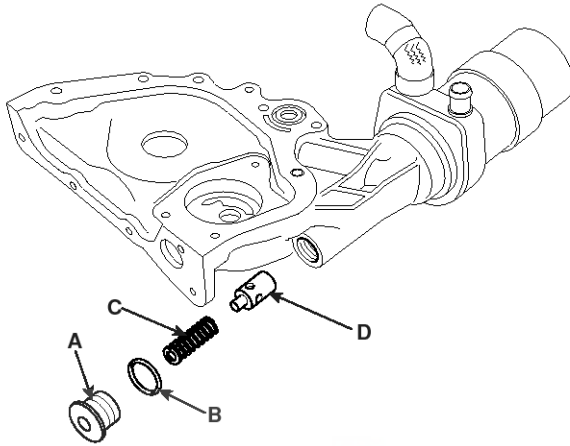

ACIE161A

2. Install the O ring(A) to the oil pump case(B) after applying engine oil.

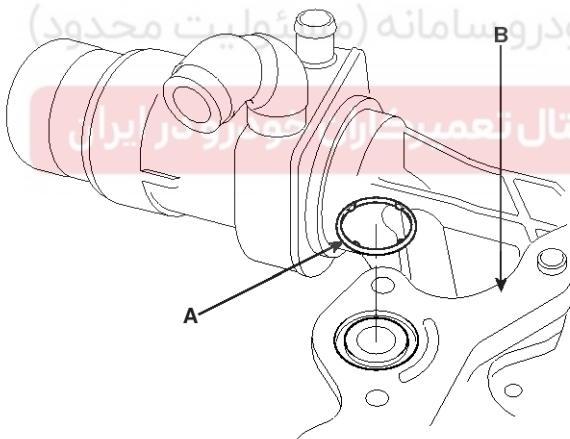

ACIE160A

3. Assemble the inner/outer rotors with engine oil the drive gear and the oil pump cover.
4. Install the oil pump cover(B) assembly to the oil pump case with the three hexagon socket head bolts(A).

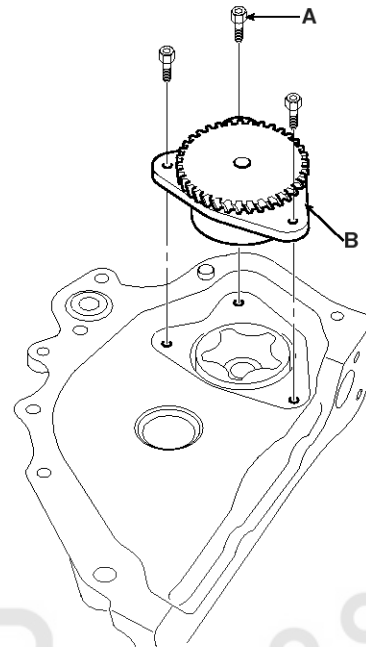

ACIE159A

5. The oil seal which was disassembled in 'Disassembly' step is recommended to be installed after the installation of the crankshaft.

Lubrication System

EM-87

Installation

1. Install the oil pump case and the oil pan on the engine block.

Tightening torque

20 ~ 27N.m (2.0 ~ 2.7kgf.m, 15 ~ 20lb-ft)

NOTICE

Standard liquid gasket : LOCTITE 5900, DREIBOND 5105 or HYLOMAR 101

2. Install the oil screen.
3. Install the oil pan.

Tightening torque

10 ~ 12N.m (1.0 ~ 1.2kgf.m, 7 ~ 9lb-ft)

NOTICE

Standard liquid gasket : LOCTITE 5900

Assemble the oil pan in 5 minutes after applying the liquid gasket.

Apply liquid gasket in a 3mm wide bead without stopping.

The clearance between the liquid gasket and the flange inner end should be 2 ~ 3mm.

4. Fill the engine oil in the room below the oil cooler (50cc).
5. Tightening the oil filter fitting, install the oil cooler and hose assembly.

NOTICE

Before assembling the oil cooler. Apply SAE 20w oil on the O rings.

Tightening torque

48 ~ 52N.m (4.8 ~ 5.2kgf.m, 35.4 ~ 38.14lb.ft)

6. Install the oil filter.

7. Install the crankshaft sprocket(B) with bolt(A).

Tightening torque

185 ~ 195N.m (1850 ~ 1950kgf.m, 136 ~ 144lb-ft)

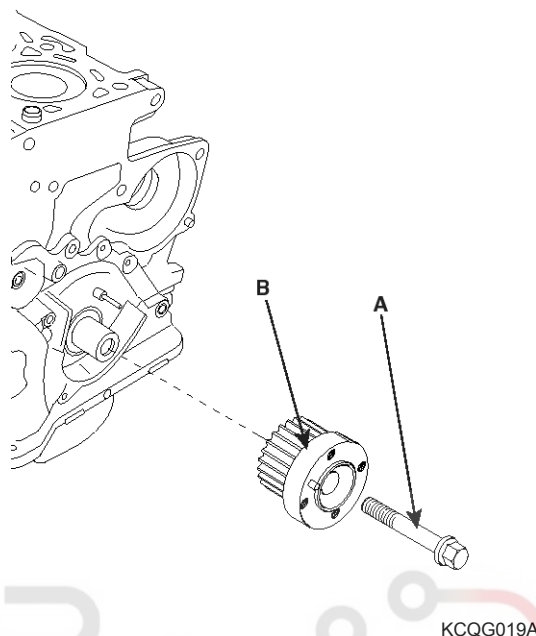

8. Install the timing belt rear cover(A).

Tightening torque

8 ~ 12N.m (80 ~ 120kgf.m, 6 ~ 9lb-ft)

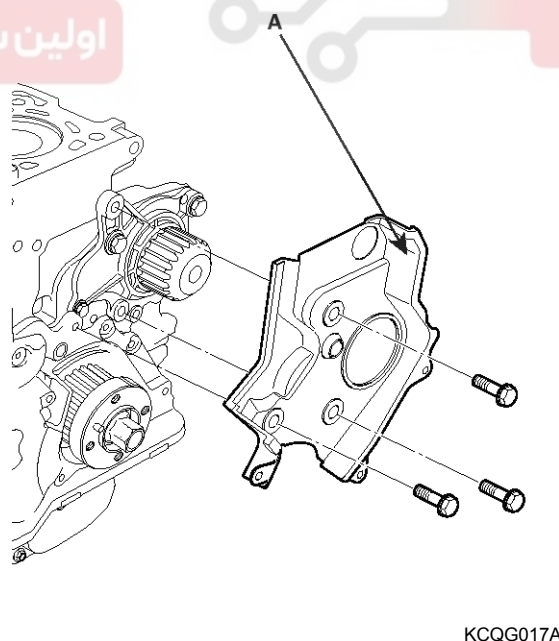

EM-88

Engine Mechanical System

9. Install the auto tensioner(A).

Tightening torque

50 ~ 55N.m (500 ~ 550kgf.m, 37 ~ 40.5lb-ft)

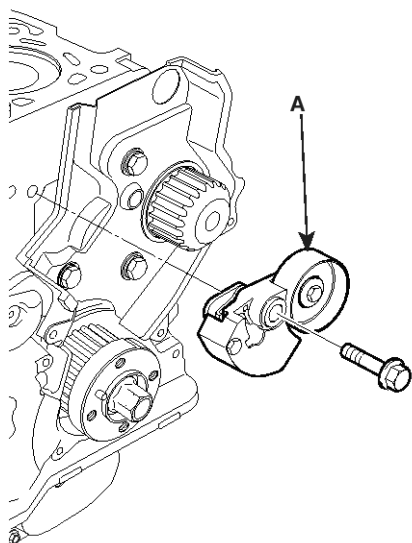

SMGEM6301D

10. Install the timing belt.

11. Install the crankshaft pulley(A).

Tightening torque

30 ~ 34N.m (300 ~ 340kgf.m, 22 ~ 25lb-ft)

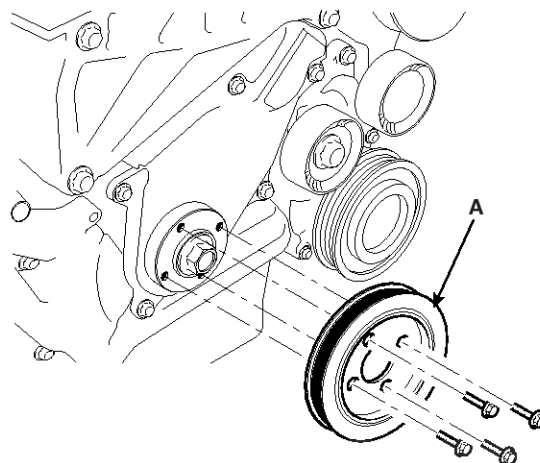

EDKD530A

دیجیتال خودرو

شرکت دیجیتال خودرو سامانه (مسئولیت محدود)

اولین سامانه دیجیتال تعمیرکاران خودرو در ایران

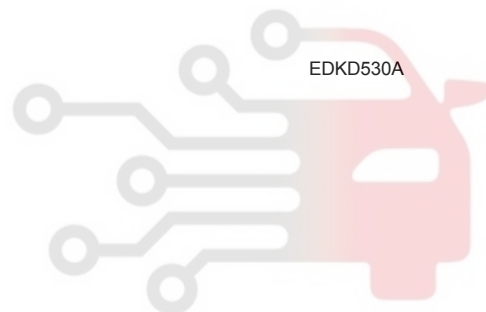

Intake And Exhaust System

EM-89

Intake And Exhaust System

Components

Intake Manifold

NOTE

- Use new gasket when reassembly.
- Check for folds or scratches on the surface of the gasket.
- Replace with a new gasket if damaged.

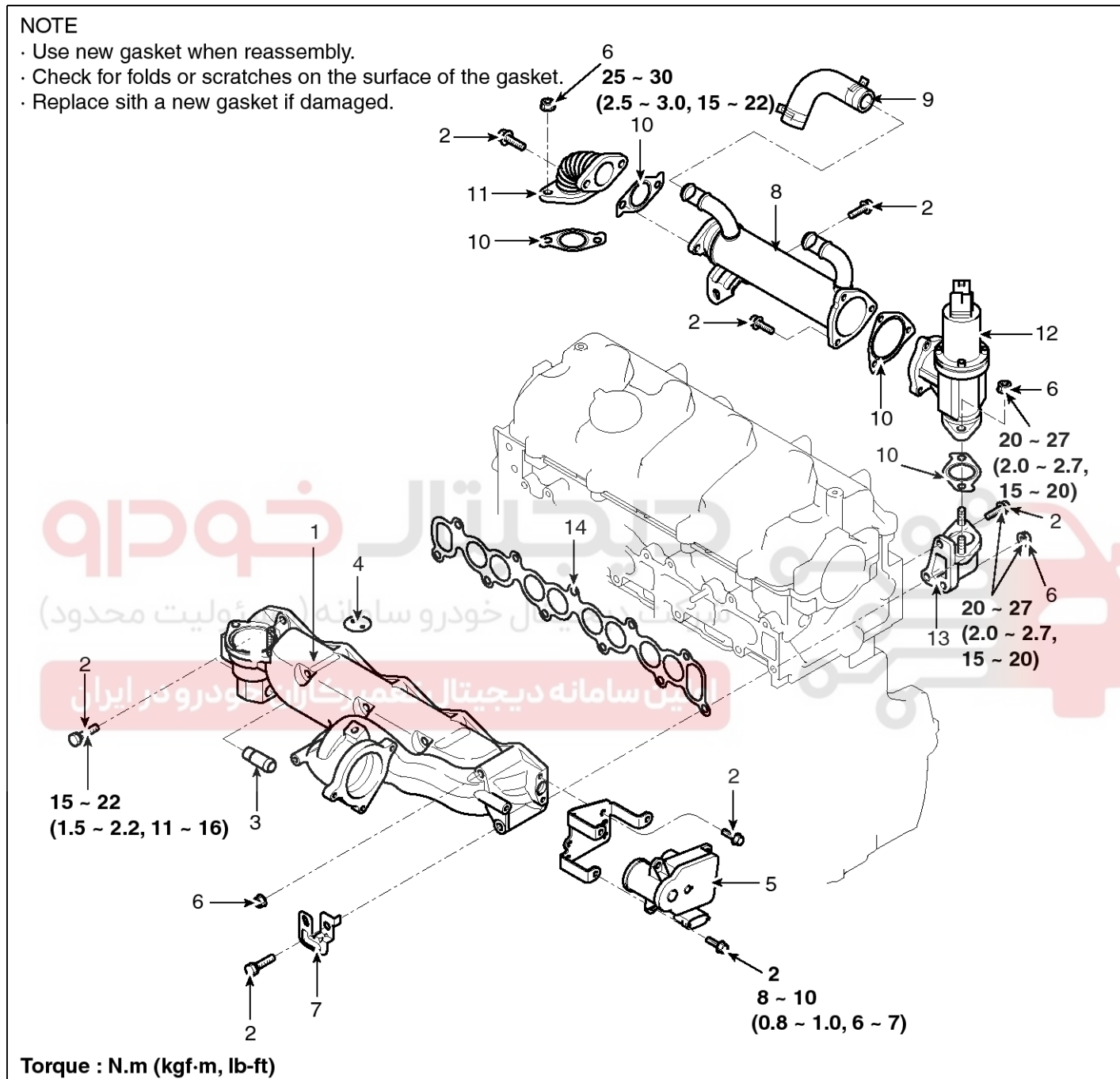

SMGM19019L

- | | | |
|-----------------------------|----------------------------|------------------------|
| 1. Intake manifold assembly | 6. Nuts | 10. Gasket |
| 2. Bolts | 7. Wiring mounting bracket | 11. EGR pipe assembly |
| 3. Water bypass connector | 8. EGR cooler | 12. EGR valve assembly |
| 4. Swirl control valve | 9. EGR cooler hose | 13. EGR elbow |
| 5. Swirl control actuator | | |

EM-90

Engine Mechanical System

Exhaust Manifold

NOTE

- Use new gasket and self-locking
- Check for folds or scratches on the surface of the gasket.
- Replace with a new gasket if damaged.

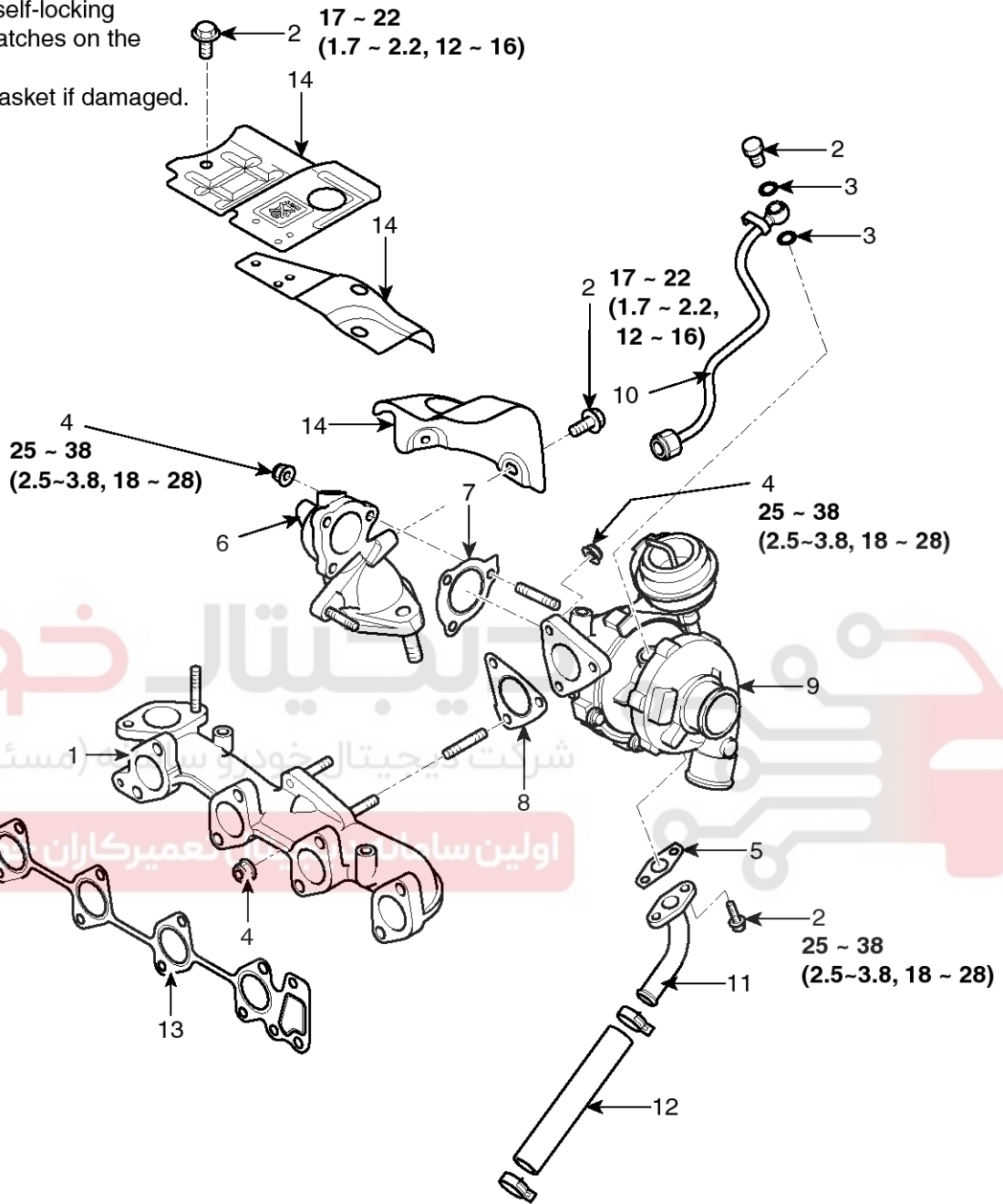

Torque : N.m (kgf-m, lb-ft)

SMGM19020L

- | | | |
|-----------------------------------|---------------------------------|-----------------------------|
| 1. Exhaust manifold | 6. Turbo charge discharger pipe | 11. Oil pipe |
| 2. Bolts | 7. Turbo charge exhaust gasket | 12. Oil hose |
| 3. Gasket | 8. Turbo charge intake gasket | 13. Exhaust manifold gasket |
| 4. Nuts | 9. Turbo charge | 14. Heat protector |
| 5. Turbo charger oil drain gasket | 10. Oil feed pipe | |

Intake And Exhaust System

EM-91

Muffler

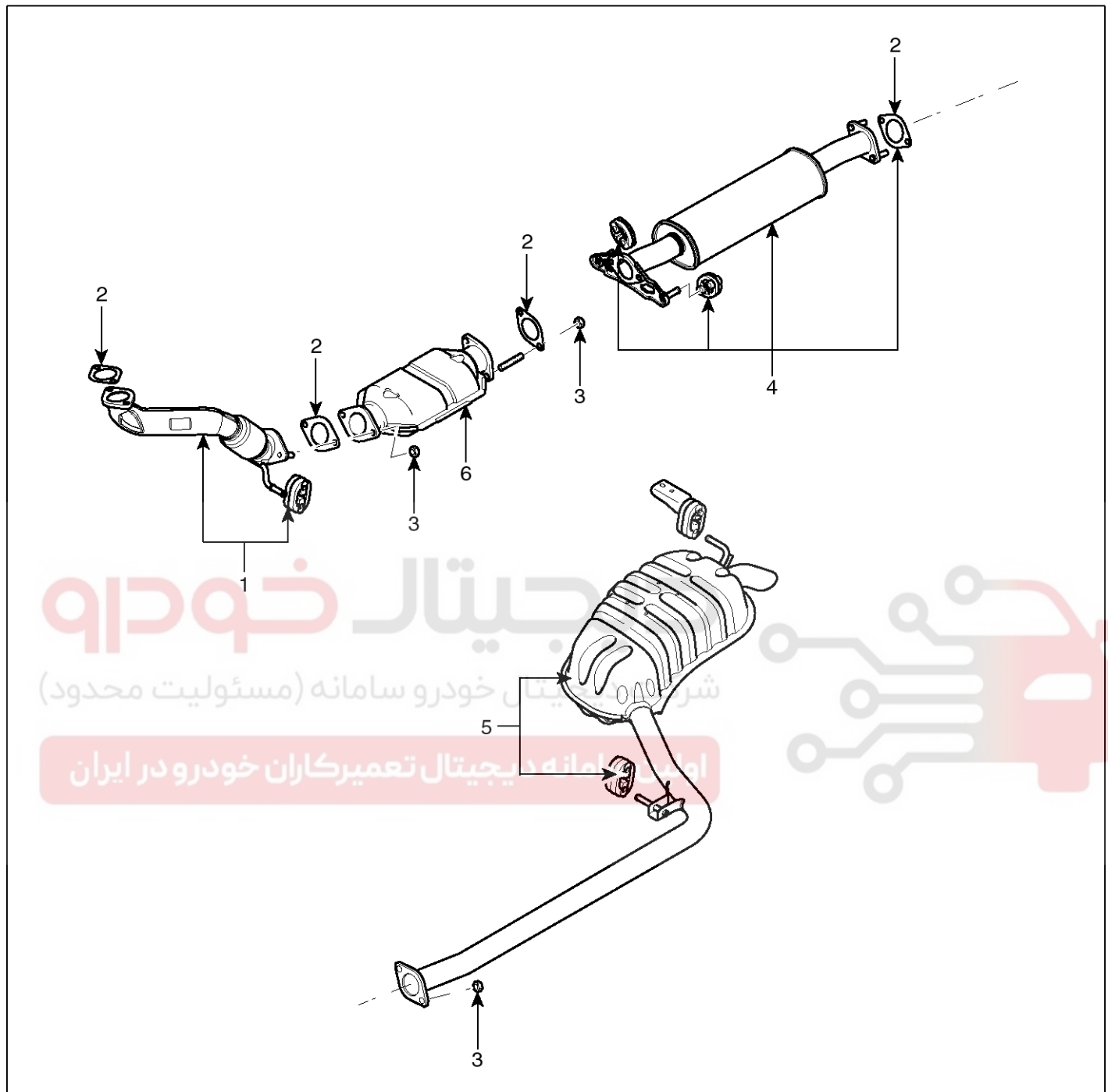

SMGM19021L

- 1. Front muffler assembly
- 2. Gasket
- 3. Nuts
- 4. Center muffler assembly
- 5. Main muffler assembly
- 6. Catalyzed Particulate Filter(CPF) converter assembly

EM-92

Engine Mechanical System

Removal

Intake Manifold

1. Remove the radiator upper hose(A) and the coolant bleed hose(B).

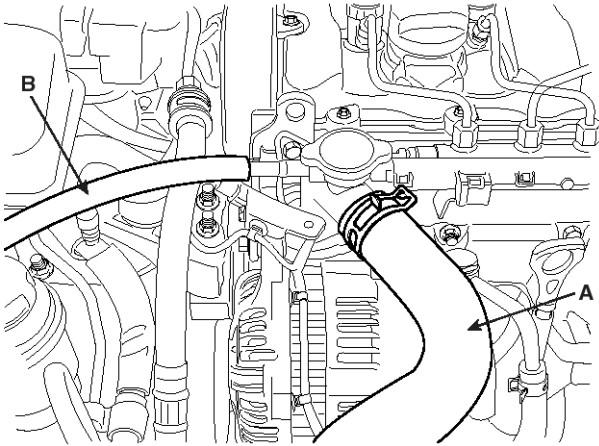

SNFEM6002D

2. Remove the alternator. (See EE group - alternator)
3. Remove the intercooler hose(A).

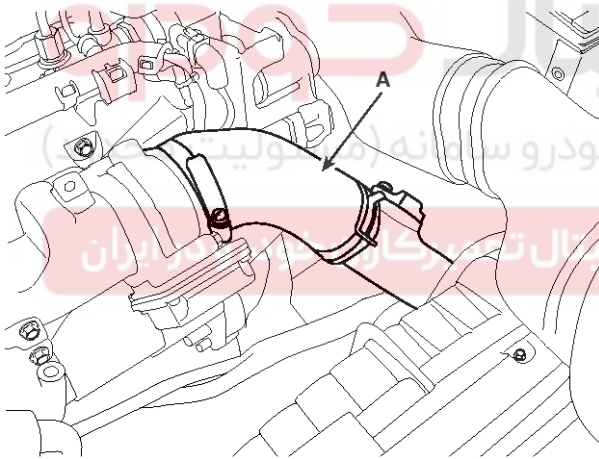

SMGEM6008D

4. Disconnect the engine wire harness connectors from intake manifold side.

- a. Disconnect the rail pressure sensor connector(A) and the water temperature sensor connector(B).

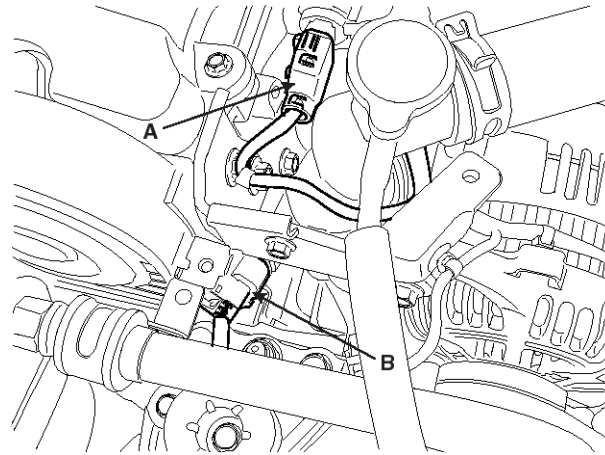

SNFEM6016D

5. Disconnect the camshaft position sensor(A), pressure control valve(B), valve control actuator (c) and throttle body actuator(D) connector.

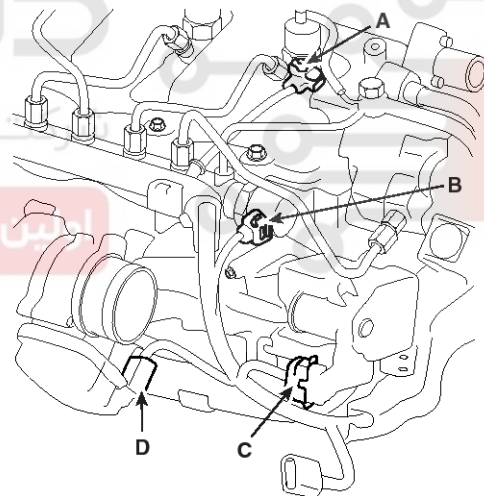

SMGEM6011D

Intake And Exhaust System

EM-93

6. Remove the oil level gauge(A).

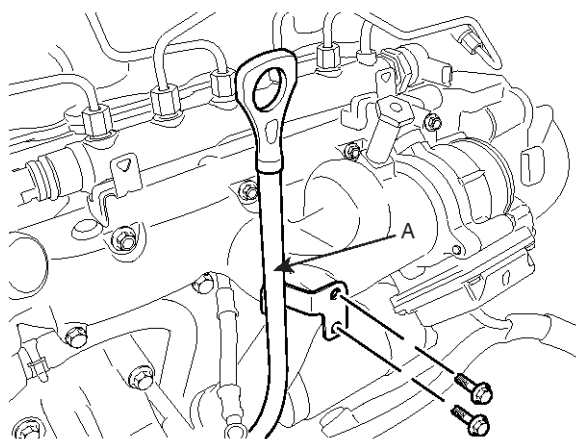

SMGEM6312D

7. Remove the thermostat housing(A).

Tightening torque :

20 ~ 25N.m (2.0 ~ 2.5kgf.m, 15 ~ 18lb-ft)



SMGEM6012D

8. Remove the EGR throttle body(A).

Tightening torque :

10 ~ 12N.m (1.0 ~ 1.2kgf.m, 7 ~ 9lb-ft)

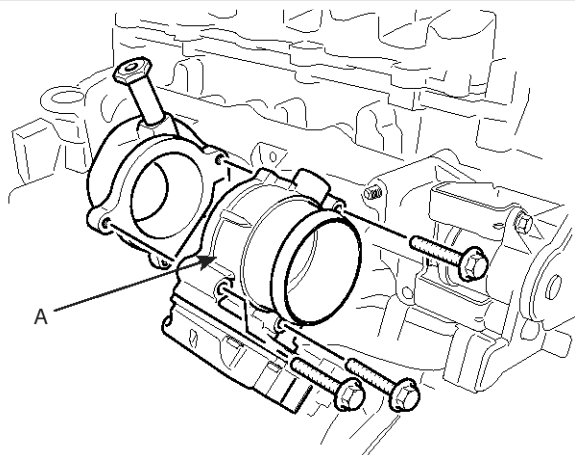

LCIG019A

9. Remove the thermostat hose(A).

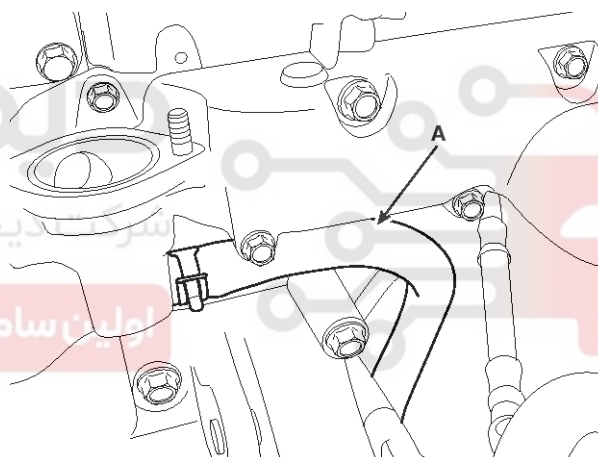

SMGEM6013D

EM-94

Engine Mechanical System

10. Remove the intake manifold(A).

Tightening torque :

15 ~ 22N.m (1.5 ~ 2.2kgf.m, 11 ~ 16lb-ft)

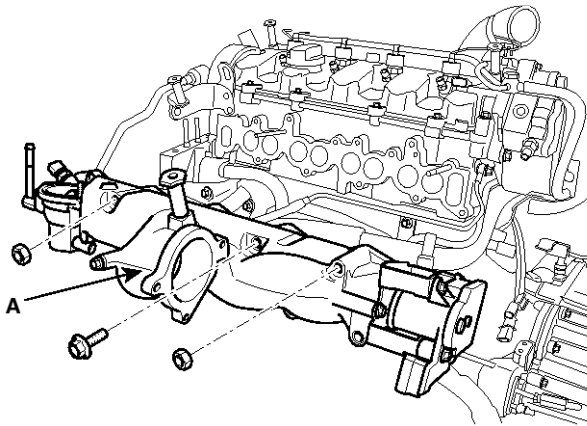

LCIG020A

11. Installation is in the reverse order of removal.

Exhaust Manifold

1. Remove the air cleaner.

- a. Disconnect the Air Flow Sensor (AFS) connect(A).
- b. Remove the air intake hose clamp first, then remove the air cleaner assembly(B).

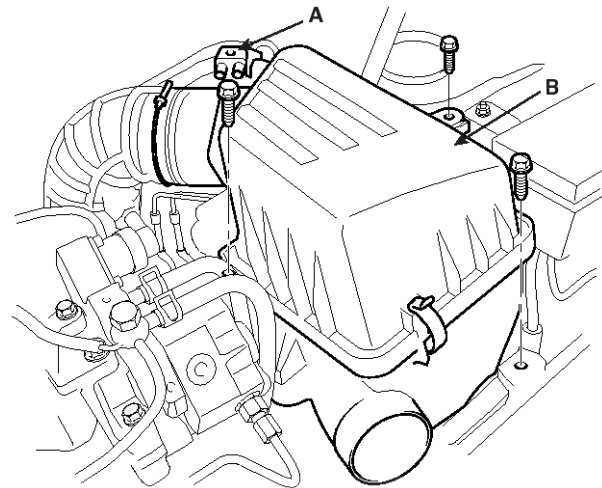

SNFEM6023D

2. Remove the front muffler(A).

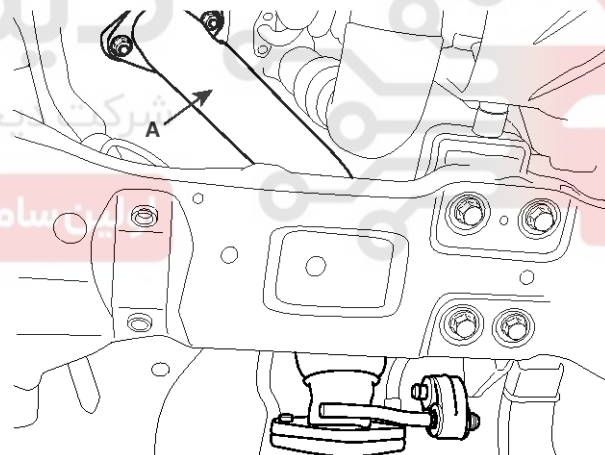

SMGEM6002D

Intake And Exhaust System

EM-95

3. Remove the intercooler pipe(A).

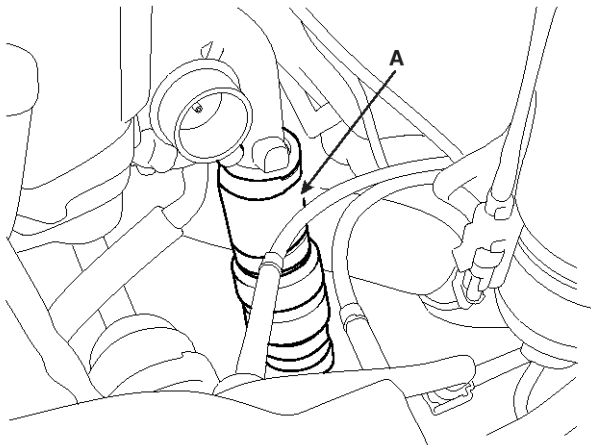

SMGEM6014D

4. Disconnect the engine wire harness connectors from exhaust manifold.

- a. Disconnect the injector connector(A).
- b. Lambda sensor connector(B) and VGT exhaust gas temperature sensor connector(C).
- c. Disconnect the EGR actuator(D), fuel temperature sensor(E) and the fuel pressure regulator connector(F).

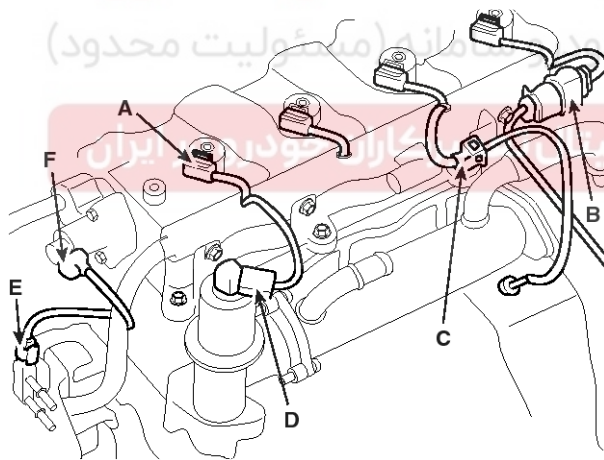

SMGEM6015D

5. Remove the brake booster vacuum hose(A).

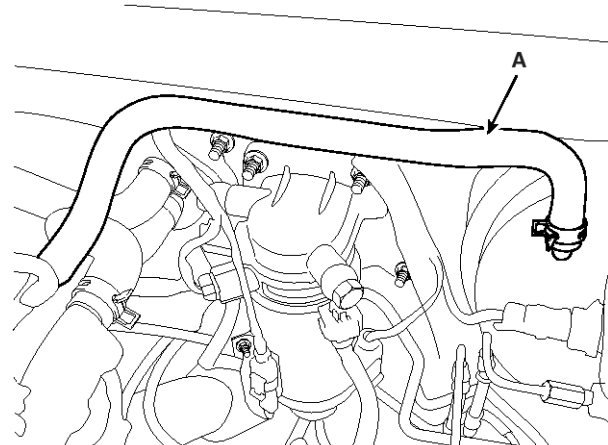

SMGM19022L

6. Remove the heater hose(A) and EGR cooler hose(B).

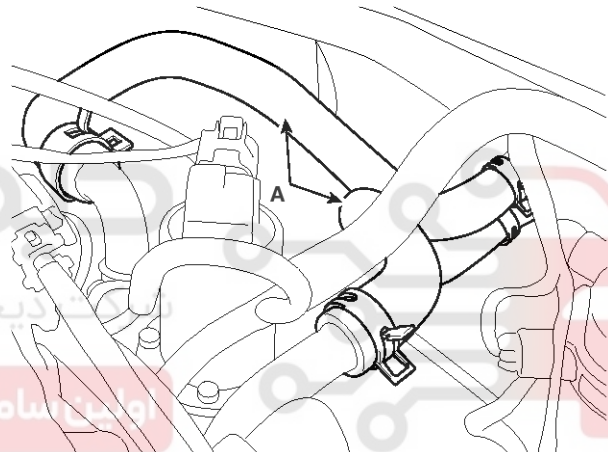

SMGEM6017D

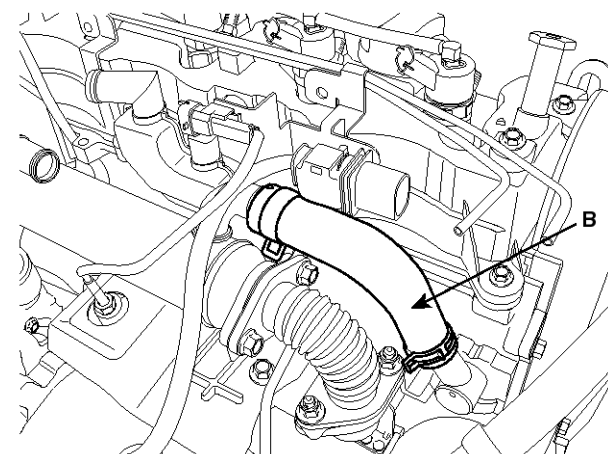

SMGEM6310D

EM-96

Engine Mechanical System

7. Remove the VGT actuator.
8. Remove the EGR valve and cooler assembly(A).

Tightening torque :

Nuts(B), Bolt(C)

20 ~ 27N.m (200 ~ 270kgf.m, 15 ~ 20lb-ft)

Nuts(D) : 25 ~ 30N.m (2.5 ~ 3.0kgf.m, 19 ~ 22lb-ft)

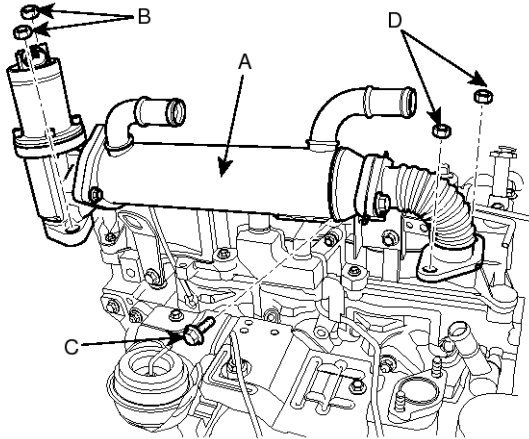

LCIG024A

9. Remove the turbo charger heat protector(A, B).

Tightening torque :

17 ~ 22N.m (1.7 ~ 2.2kgf.m, 12 ~ 16lb-ft)

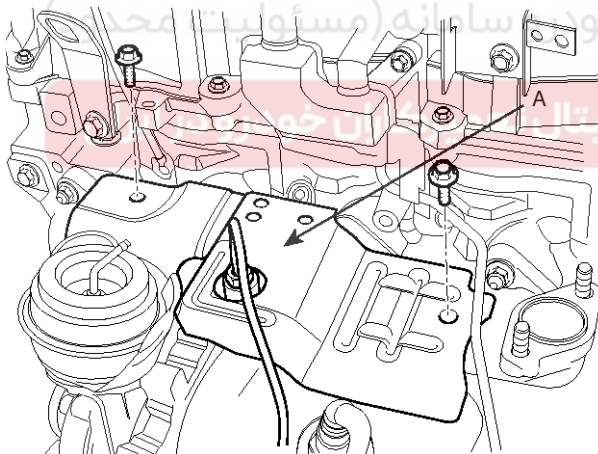

LCIG026A

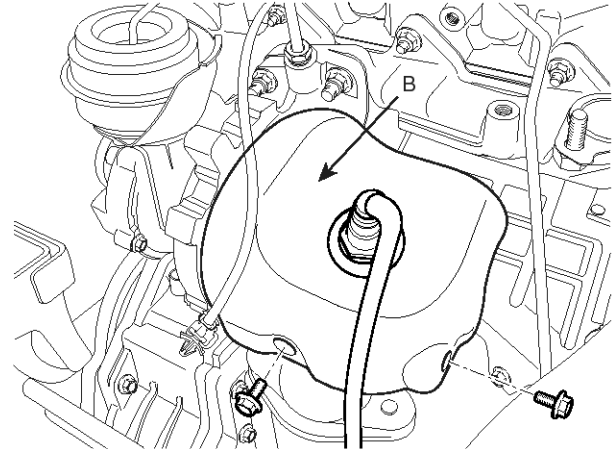

LCIG027A

10. Remove the heater pipe heat protector(A).

Tightening torque :

8 ~ 10N.m (0.8 ~ 1.0kgf.m, 6 ~ 7lb-ft)

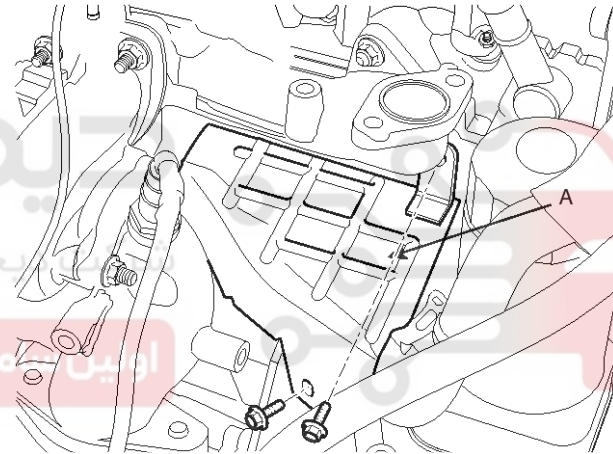

LCIG028A

11. Disconnect the turbo charger oil feed pipe(A) and oil return hose(B).

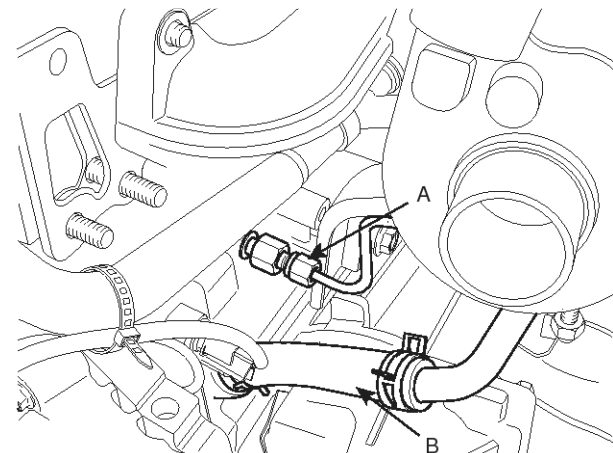

LCIG029A

Intake And Exhaust System

EM-97

12.Remove the turbocharger support bracket mounting bolts(A).

Tightening torque :

35 ~ 45N.m (3.5 ~ 4.5kgf.m, 26 ~ 33lb-ft)

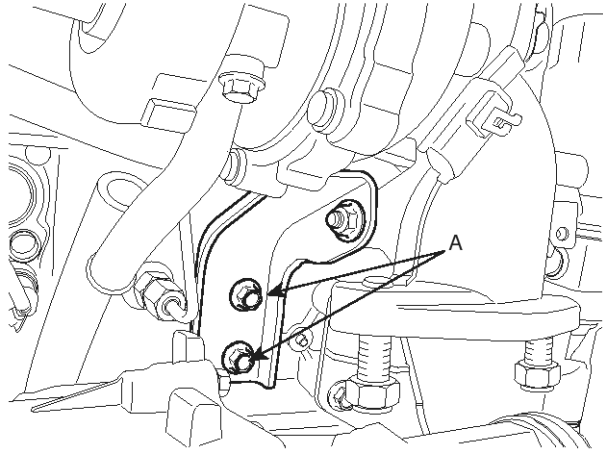

LCIG030A

13.Remove the EGR elbow(A) and turbocharger & exhaust manifold assembly(B).

Tightening torque :

EGR elbow bolt and nuts

20 ~ 27N.m (2.0 ~ 2.7kgf.m, 15 ~ 20lb-ft)

Exhaust manifold nuts

30 ~ 35N.m (3.0 ~ 3.5kgf.m, 22 ~ 26lb-ft)

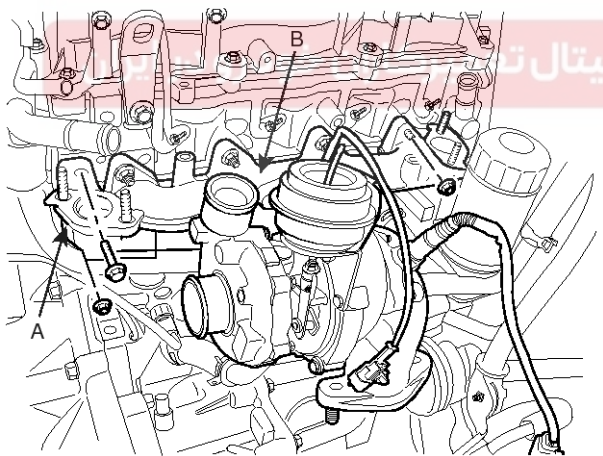

LCIG031A

14.Installation is in the reverse order of removal.

Muffler

1. Remove the front muffler(A).

Tightening torque :

40 ~ 60N.m (4.0 ~ 6.0kgf.m, 30 ~ 43lb-ft)

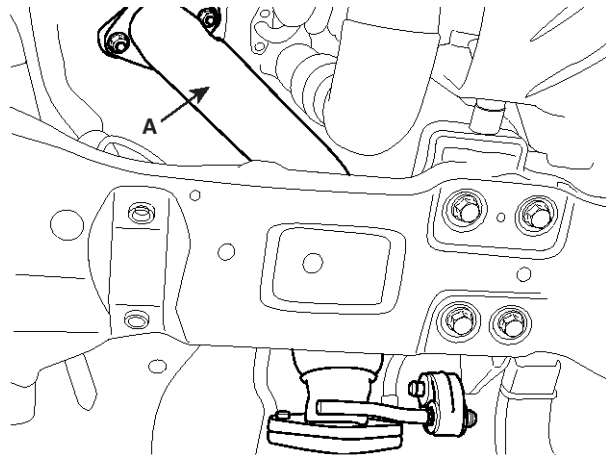

SMGEM6002D

2. Remove the Catalyzed Particulate Filter(CPF)(A) after disconnecting the differential pressure hoses(B) and exhaust gas temperature sensor(C).

Tightening torque :

40 ~ 60N.m (4.0 ~ 6.0kgf.m, 30 ~ 43lb-ft)

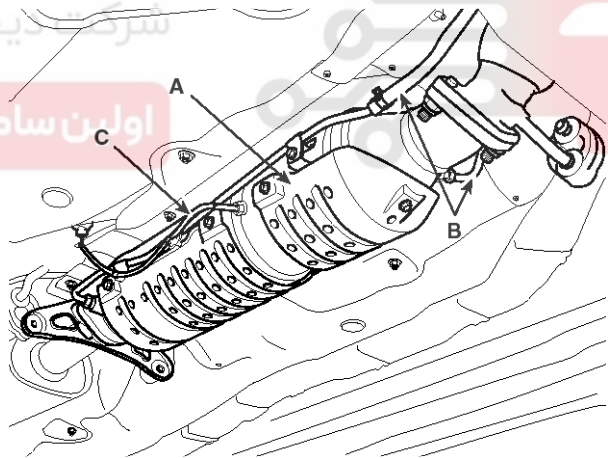

SMGEM6003D

EM-98

Engine Mechanical System

3. Remove the center muffler(A).

Tightening torque :

40 ~ 60N.m (4.0 ~ 6.0kgf.m, 30 ~ 43lb-ft)

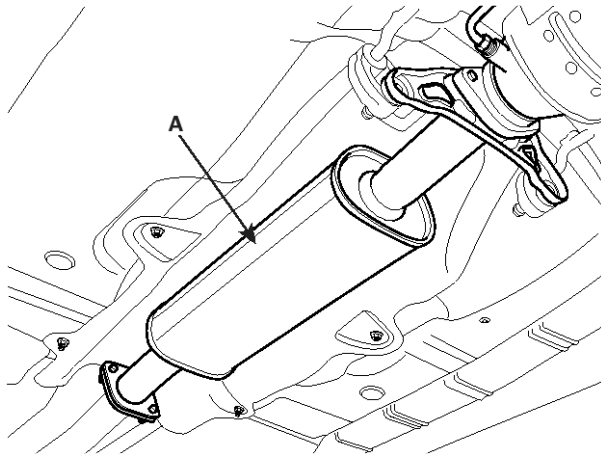

SMGEM6004D

4. Remove the main muffler(A).

Tightening torque :

40 ~ 60N.m (4.0 ~ 6.0kgf.m, 30 ~ 43lb-ft)

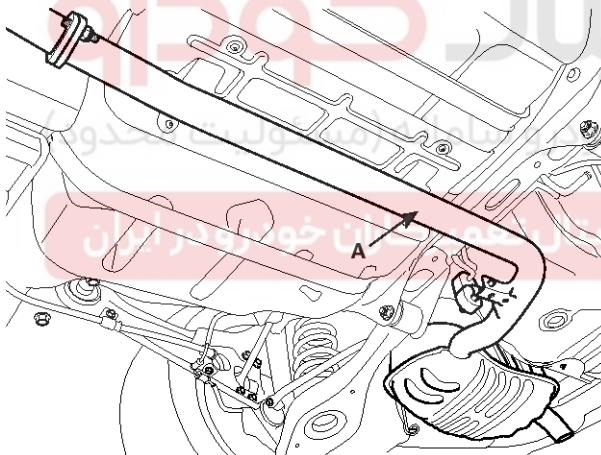

SMGEM6005D

5. Installation is in the reverse order of removal.

Replacement

Intercooler

1. Remove the radiator.(See cooling system- radiator)
2. Remove the intercooler mounting bolts(A).

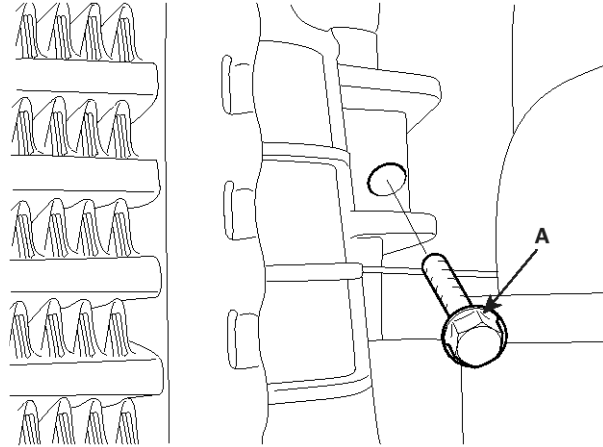

SMGEM6006D

3. Because the intercooler and condenser owe combined with a cilp(A), separate the intercooler form the condenser by pushing the intercooler downwards and then remove the intercooler by lifting to the upwards.

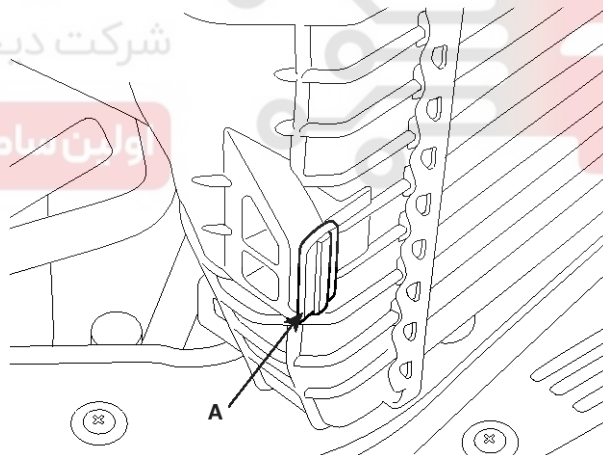

SMGEM6007D

4. Installation is in the reverse order of removal.